

# INSTALLATION MANUAL

# 70102

## Level of Difficulty

Moderate

Installation difficulty levels are based on time and effort involved and may vary depending on the installer level of expertise, condition of the vehicle and proper tools and equipment.

## Installed Attachment Tabs

Height	14-1/2"
Width	24"

## Parts List

Item	Qty	Description
1	1	Tow bar base plate
2	2	Spacer plate, 1/2"
3	2	Safety cable, 3,500 lbs.
4	2	Tow bar mounting tab
5	4	Square hole spacer, 1/4" x 1" x 2-1/2"
6	4	Carriage bolt, 1/2"-13 x 2", grade 8
7	4	Flange nut, 1/2"-13, grade 8
8	2	Square hole spacer, 3/8" x 1-1/4" x 2-1/2"
9	2	Carriage bolt, 5/8"-11 x 2", grade 8
10	2	Flange nut, 5/8"-11, grade 8
11	2	Quick link, 1/4"
12	2	Socket plug

## Tools Required

Torque wrench	Drill
Socket, 3/4"	Drill bit, 17/32"
Socket, 5/16"	Tape measure
Socket, 18mm	Large vise grip
Reciprocating saw	Utility knife
Fishwire, 1/2" (includes four)	Fishwire, 5/8" (includes six)
Phillips screwdriver	Trim removal tool

## ⚠ WARNING

Never exceed the vehicle manufacturer's recommended gross vehicle weight rating (GVWR).

## Product Photo



Not pictured: Safety cables, quick links and socket plugs

## ⚠ CAUTION

Take care when cutting any plastic or metal as injury may occur if done improperly.

## NOTICE

Visit [www.curtmfg.com](http://www.curtmfg.com) for a full-color copy of this instruction manual, as well as helpful videos, guides and much more!

Before you begin installation, read all instructions thoroughly.

Proper tools will improve the quality of installation and reduce the time required.

This installation requires the front underbody panel and metal bumper to be removed and reinstalled. Some drilling and trimming are required.

To help prevent damage to the product or vehicle, refer to the specified torque specifications when securing hardware during the installation process.

If equipped, we recommend removing the base plate attachment tabs when not in use.

## SAFETY INSTRUCTIONS

Safety glasses should be worn at all times while installing this product.

## Product Registration and Warranty

CURT stands behind our products with industry-leading warranties. To get copies of the product warranties, register your purchase or provide feedback, visit: [warranty.curtgroup.com/surveys](http://warranty.curtgroup.com/surveys)

# ASSEMBLY

## Parts List

Item	Qty	Description
1	1	Tow bar base plate
2	2	Spacer plate, 1/2"
3	2	Safety cable, 3,500 lbs.
4	2	Tow bar mounting tab
5	4	Square hole spacer, 1/4" x 1" x 2-1/2"
6	4	Carriage bolt, 1/2"-13 x 2", grade 8
7	4	Flange nut, 1/2"-13, grade 8
8	2	Square hole spacer, 3/8" x 1-1/4" x 2-1/2"
9	2	Carriage bolt, 5/8"-11 x 2", grade 8
10	2	Flange nut, 5/8"-11, grade 8
11	2	Quick link, 1/4"
12	2	Socket plug

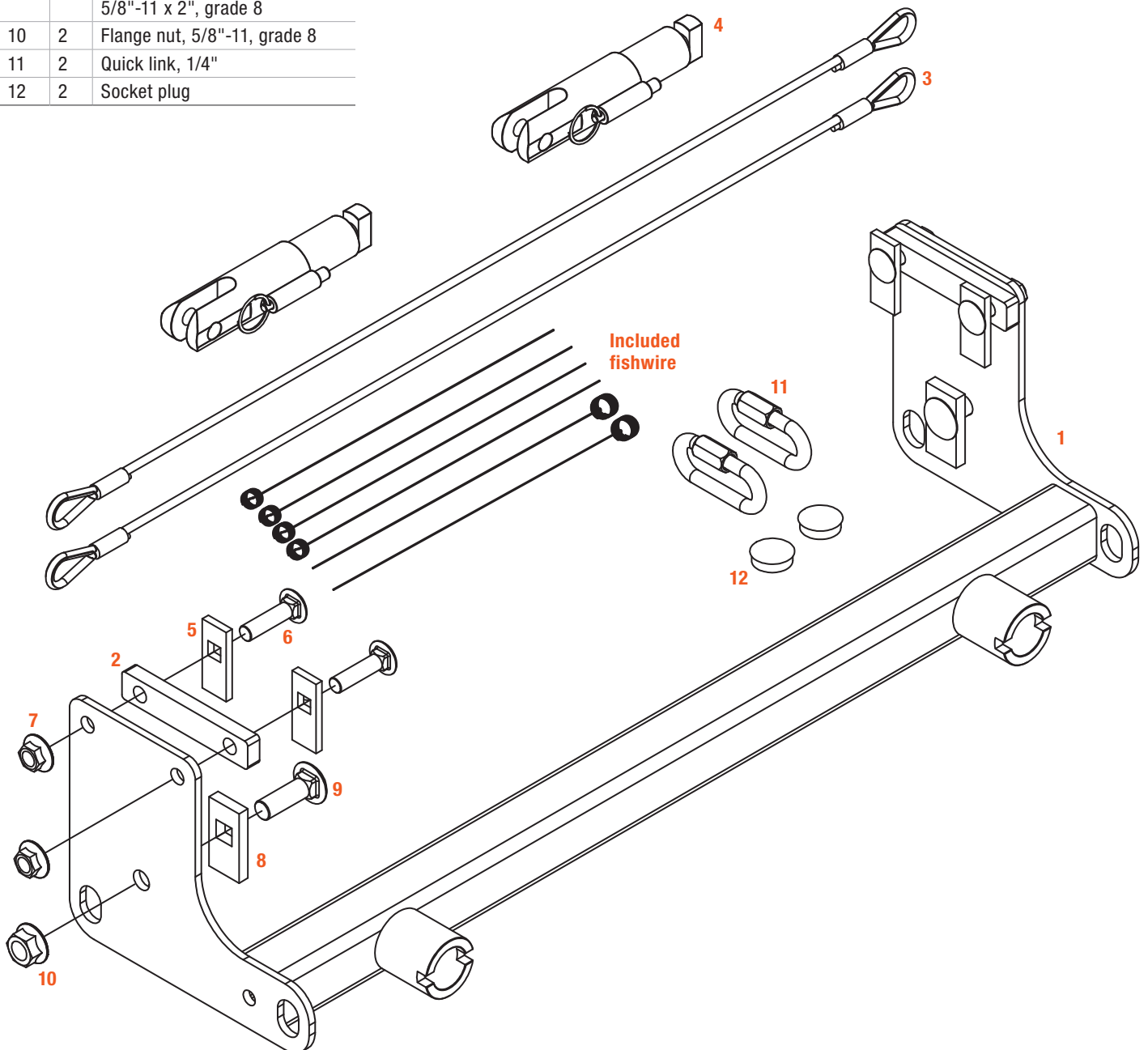

# TOW BAR BASE PLATE INSTALLATION

## ALL MODELS

### Step 1

Use a Phillips head screwdriver and trim removal tool to remove the four push pins from the bottom of the underbody panel – two on each side of the vehicle.



### Step 2

Use a Phillips head screwdriver and trim removal tool to remove the two push pins from the backside tabs of the underbody panel.

Set the panel aside.



### Step 3

Unplug the bumper fog lights.

Then, use an 18mm socket to remove the four bolts on the outer edge of the frame – two bolts on either side of the vehicle.

Use an 18mm socket to remove the four bolts on the inner edge of the frame – two on either side of the vehicle.



### Step 4

Carefully pull the bumper out and unclip the wiring harness from the back side.

With the harness separated from the bumper, set the bumper aside.

For 2007 - 2009 models continue to Step 5.

For all other models years, skip to Step 6.





# FOR 2007 - 2009 MODELS

## Step 5 - For 2007 - 2009 Models ONLY

Your vehicle has a frame extension that needs to be trimmed for proper installation. Use a reciprocating saw or die grinder to cut the extension flush with the vertical portion of the frame.

Repeat on the other side of the vehicle.

To help prevent corrosion, we recommend finishing any exposed metal edges with paint.



# ALL MODELS (CONTINUED)

## Step 6

Position the tow bar base plate (#1) so the lower hole matches up with the middle hole on the vehicle frame. Making sure it is level with the frame, clamp the base plate into place.

Repeat on the other side of the vehicle.

Secure the base plate by fishwiring a 5/8"-11 x 2" carriage bolt (#9) and a 3/8" square hole spacer (#8) into the middle hole in the frame from inside the frame and secure with a 5/8"-11 flange nut (#10).

Torque the 5/8" hardware to 180 lb-ft., and repeat on the other side of the vehicle.

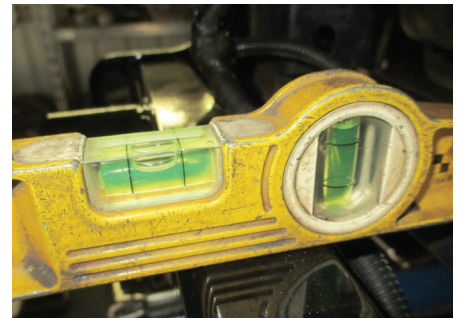

## Step 7

Using the top two tow bar base plate (#1) holes as a guide, drill two 17/32" holes in the vehicle frame. Then, position a 1/2" spacer plate (#2) between the base plate and the frame.

Fishwire two 1/2"-13 x 2" carriage bolts (#6) with 1/4" square hole spacers (#5) through the end of the frame into the 1/2" spacer plate (#2) and tow bar base plate (#1). Loosely install the 1/2" flange nuts (#7).

Torque the hardware to 110 lb-ft., and repeat on the other side of the vehicle.

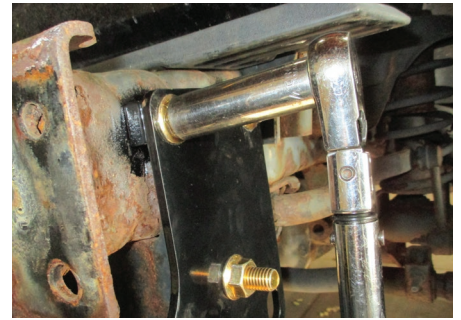
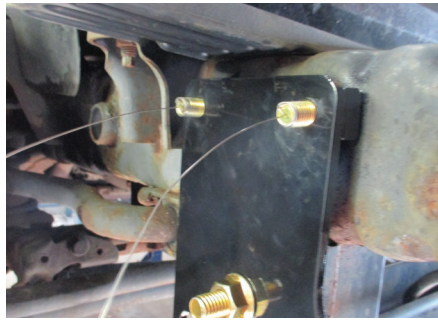
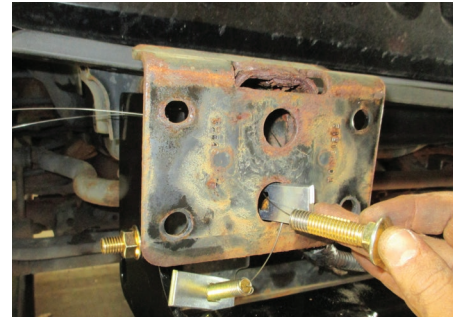
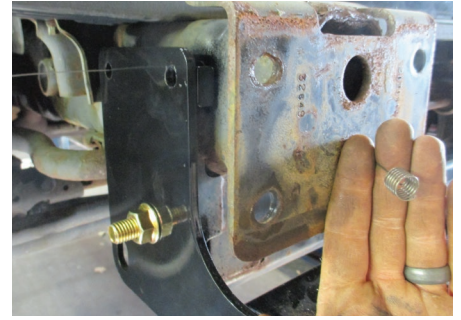

## Step 8

Reinstall the factory bumper, making sure to clip the wiring harness back into place and plug in the fog lights.





### Step 9

Install the permanent safety cables (#3) and quick links (#11), looping them around the vehicle frame and linking them to the tow bar base plates (#1). There must be one cable on each side of the vehicle.

Make sure the cables do not pinch or interfere with any hoses, wiring or other components.

See 'Installing the Permanent Base Plate Safety Cables' for additional information.



### Step 10

Hold up the underbody in its original position and mark where the fascia will need to be trimmed to make space for the base plate side bracket.

Both sides of the vehicle will need to be trimmed. Trim off the marked areas and reinstall the panel.

When ready to tow, install the tow bar mounting tabs (#4). When not towing, insert the socket plugs (#12) into the ends of the tow bar base plates (#1).



### Final Installed Image



# SAFETY CABLE INSTALLATION

## Installing the Permanent Base Plate Safety Cables

When dinghy towing a vehicle with a tow bar, base plate safety cables should be used at all times. In the event of a disconnect, the safety cables are designed to help prevent complete vehicle separation. When installing the safety cables, use the illustrations below as a guide.

### Installation guidelines

1. The cables must be connected to the base plate and the vehicle frame.
2. Two cables must be installed.
3. Each cable must meet or exceed the gross weight of the towed vehicle.
4. Make sure cables do not pinch or interfere with hoses, wiring or other components.

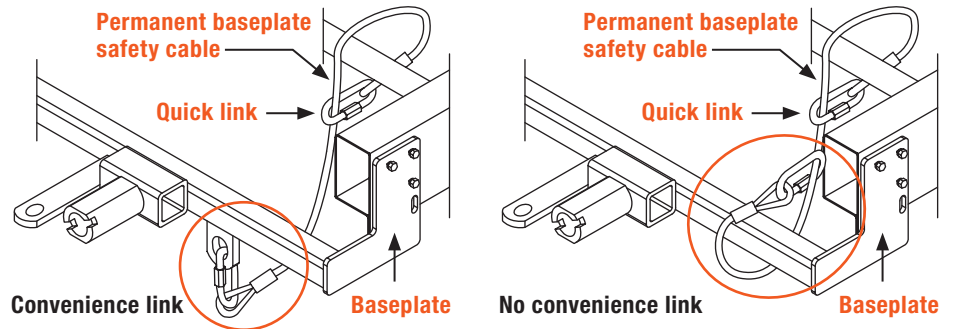

**Note:** Base plate safety cables are not a replacement for safety chains connecting the tow vehicle to the towed vehicle.

## ADDITIONAL INFORMATION

### Towing Tips

#### Check your equipment

Periodically check the condition of all towing equipment. Ensure all fasteners are tight and that all structural components are sound. Do not tow with worn or damaged parts.

#### Towing vehicle and trailer manufacturer's recommendations

Review the owner's manual for your towing vehicle and trailer for specific recommendations, capacities and requirements.