



7/15/2010

C-219 SUBKIT

DODGE 1500/2500/3500

20,000 LBS GTW GOOSENECK KIT

WARNING!! BRAKE, FUEL, AND ELECTRICAL LINES MAY NEED TO BE LOOSENED OR REPOSITIONED TO PROVIDE CLEARANCE FOR NEW HARDWARE. ALL MODELS REQUIRE MODIFICATION OR REMOVAL OF HEAT SHIELDS

PARTS LIST

- (8) 1/2-13 x 4 1/2 Hex Bolt
- (8) 1/2-13 Flange Nut
- (8) 1/2 Washer
- (12) Half Moon Spacer (CM-SP27)
- (1) Tube Spacer (CM-TS2)
- (4) 5/8" Flange Nuts
- (1) CM-C655-EH

INSTALLATION STEPS

****REMOVE SPARE TIRE FOR INSTALLATION****
****FOR MEGA CAB INSTALLATIONS, REPLACE REAR MOST EXHAUST HANGER WITH CM-C655-EH(CURT SUPPLIED HANGER)****

- 1) Install crossarms by sliding them into gap between the truck bed and frame from inside the wheel well. **As shown in Figure 1.**
- 2) **For all applications, the notched side plate indicates that it is for the driver side.** Align the folds of the plate in between the bed frame rails, and over top of the truck frame as shown in **Figure 3** (Page 2). Hang the side plates from 5/8" studs, which extend from the crossarms. Fasten each plate with two 5/8" flange nuts provided. Finger tight only.
- 3) Secure each side plate to the frame rail using two mounting straps along with four 1/2" hex bolts as shown in **Figure 3** (Page 2). Use 1/2" flange nuts to secure in place. Finger tight only.
- 4) Rotate the crossarms until they contact the truck bed. Center the rear crossarm studs in the side plate slots as shown in **Figure 2**. Use a 15/16" wrench to tighten the 5/8" flange nuts on the rear crossarm to the side plates.(Use the tube spacer for correct spacing between the crossarms.) Repeat for front crossarm. **(Note: Do not tighten crossarms until center section installation is complete.)**
- 5) **Be sure the crossarms are vertical to the truck bed before drilling!** With crossarms secure and evenly spaced, drill a hole through the truck bed at the center of each cross arm mounting hole.
- 6) From inside the truck bed, center the six pilot holes with the letter "A" on the C-52 cutting template. Fasten the template to the truck bed with tape. Once fastened, drill four 1/8" pilot holes through section lettered "B". **(Be sure to check for brake lines and/or fuel lines before drilling.)**
- 7) With the pilot holes drilled, use a sabre saw to cut out section "C".
- 8) Remove template and drill out the six pilot holes with a 21/32" drill bit. Set your C-52 folding hitch ball into place.
- 9) Attach the C-52 to the crossarms using six 5/8" carriage bolts and flange nuts. Torque bolts to 115 lb-ft. **(Note: Shims (half moon spacers) must be placed under each bolt between crossarms and C-52 to prevent truck corrugations from collapsing.)**
- 10) After the C-52 has been fastened to the crossarms. Torque all 5/8" hardware to 115 lb-ft.
- 11) Torque all 1/2" hardware to 75 lb-ft.

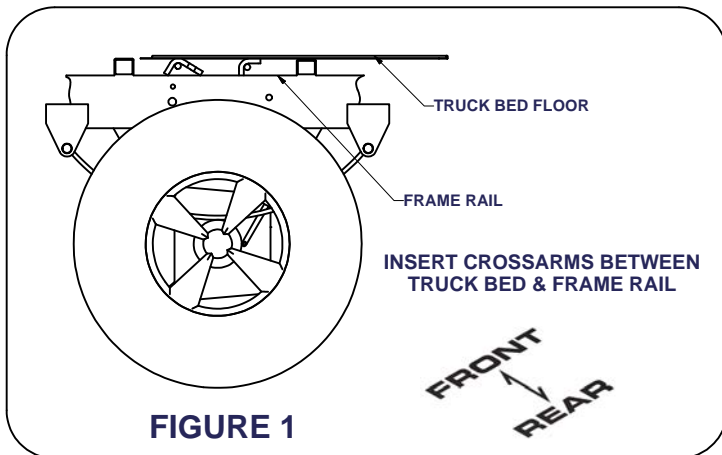

FIGURE 1

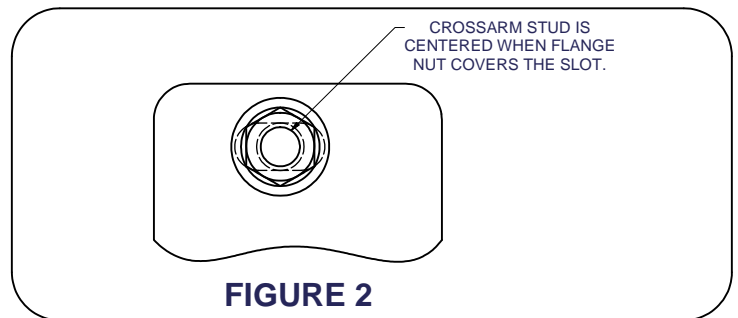

FIGURE 2

Curt Manufacturing Inc., warrants this product to be free of defects in material or workmanship at the time of retail purchase by the original purchaser. If the product is found to be defective, Curt Manufacturing Inc., may repair or replace the product, at their option, when the product is returned, prepaid, with proof of purchase. Alteration to, misuse of, or improper installation of this product voids the warrant. Curt Manufacturing Inc.'s liability is limited to repair or replacement of products found to be defective, and specifically excludes liability for incidental or consequential loss or damage.

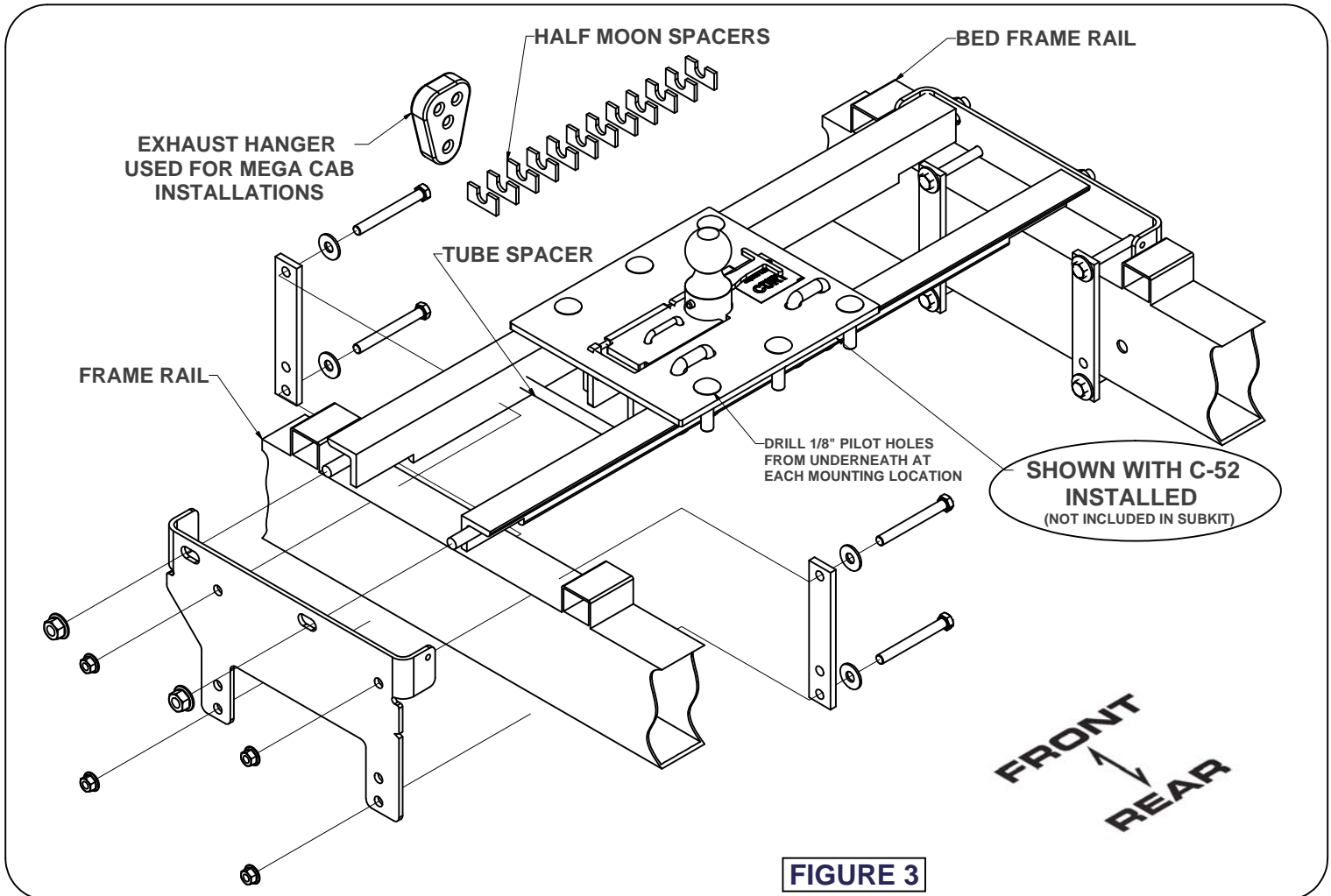
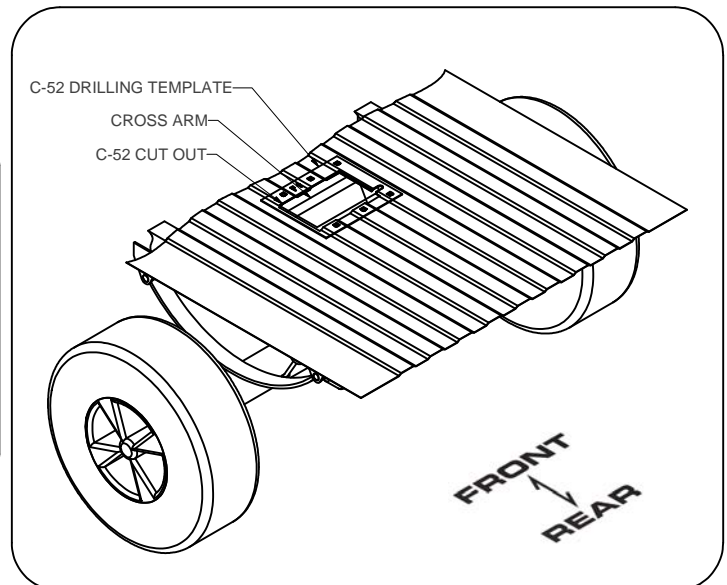
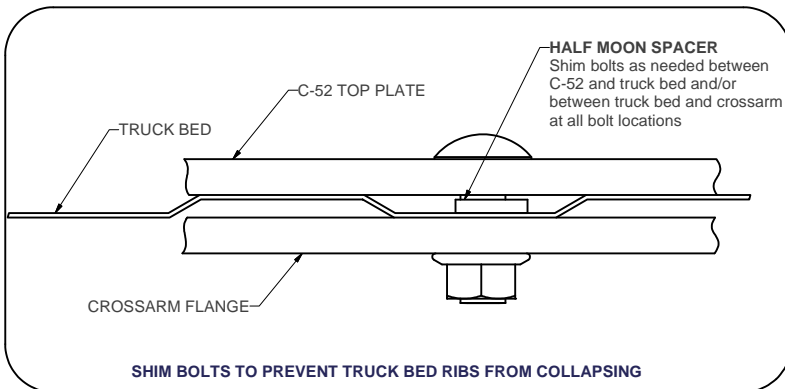

FIGURE 3



Curt Manufacturing Inc., warrants this product to be free of defects in material or workmanship at the time of retail purchase by the original purchaser. If the product is found to be defective, Curt Manufacturing Inc., may repair or replace the product, at their option, when the product is returned, prepaid, with proof of purchase. Alteration to, misuse of, or improper installation of this product voids the warrant. Curt Manufacturing Inc.'s liability is limited to repair or replacement of products found to be defective, and specifically excludes liability for incidental or consequential loss or damage.