

33328

HONDA PILOT AND RIDGELINE

10/12/2012

GROSS LOAD CAPACITY WHEN USED AS A WEIGHT CARRYING HITCH: 3,500 LBS. TRAILER WEIGHT & 350 LBS. TONGUE WEIGHT.
 GROSS LOAD CAPACITY WHEN USED AS A STRAIGHT LINE PULL: 9,000 LBS. MAX. LINE PULL.
***** DO NOT EXCEED VEHICLE MANUFACTURER'S RECOMMENDED TOWING CAPACITY. *****
 HAVING INSTALLATION QUESTIONS? CALL TECHNICAL SUPPORT AT 1-800-798-0813

Parts List			
ITEM	QTY	PART NUMBER	DESCRIPTION
1	4	M12-1.25 x 35mm	HEX BOLT
2	4	1/2"	CONICAL TOOTHED WASHER
3	2	CM-SP7	.250 x 1.00 x 2.00" SQUARE HOLE SPACER
4	2	7/16-14	HEX FLANGE NUT
5	2	7/16-14 x 1 1/2	CARRIAGE BOLT
6	1	7_16 FISHWIRE	7/16" FISHWIRE

TOOLS REQUIRED
RATCHET
6" EXTENSION
TORQUE WRENCH
SMALL SCREWDRIVER
10mm SOCKET
17mm SOCKET
11/16" SOCKET
PRY BAR

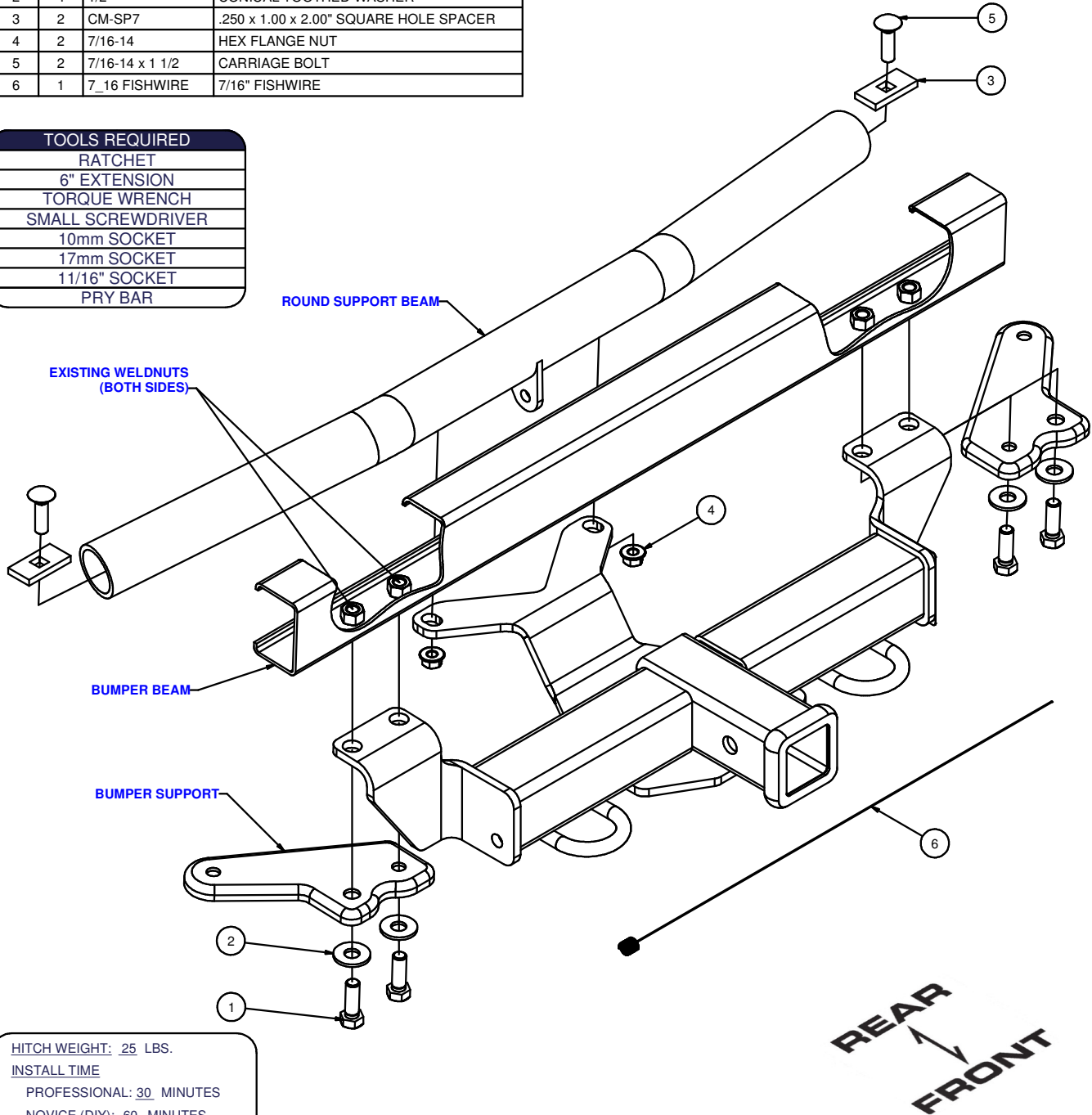

HITCH WEIGHT: 25 LBS.
 INSTALL TIME
 PROFESSIONAL: 30 MINUTES
 NOVICE (DIY): 60 MINUTES
 INSTALL NOTES:
 - LOWER FASCIA
 - TRIM FASCIA
 - NO DRILLING REQUIRED

PERIODICALLY CHECK THIS RECEIVER HITCH TO ENSURE THAT ALL FASTENERS ARE TIGHT AND THAT ALL STRUCTURAL COMPONENTS ARE SOUND.

Curt Manufacturing LLC., warrants this product to be free of defects in material and/or workmanship at the time of retail purchase by the original purchaser. If the product is found to be defective, Curt Manufacturing LLC., may repair or replace the product, at their option, when the product is returned, prepaid, with proof of purchase. Alteration to, misuse of, or improper installation of this product voids the warranty. Curt Manufacturing LLC.'s liability is limited to repair or replacement of products found to be defective, and specifically excludes liability for incidental or consequential loss or damage.

33328

HONDA PILOT AND RIDGELINE

GROSS LOAD CAPACITY WHEN USED AS A WEIGHT CARRYING HITCH: 3,500 LBS. TRAILER WEIGHT & 350 LBS. TONGUE WEIGHT.
GROSS LOAD CAPACITY WHEN USED AS A STRAIGHT LINE PULL: 9,000 LBS. MAX. LINE PULL.
*** **DO NOT EXCEED VEHICLE MANUFACTURER'S RECOMMENDED TOWING CAPACITY.** ***
HAVING INSTALLATION QUESTIONS? CALL TECHNICAL SUPPORT AT 1-800-798-0813

NOTE: DIMENSIONS ARE APPROXIMATE CONFIRM FIT PRIOR TO TRIMMING

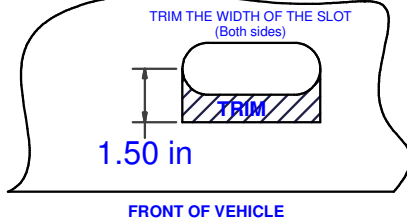

FASCIA TRIMMING DIAGRAM A
(2011 and older models)

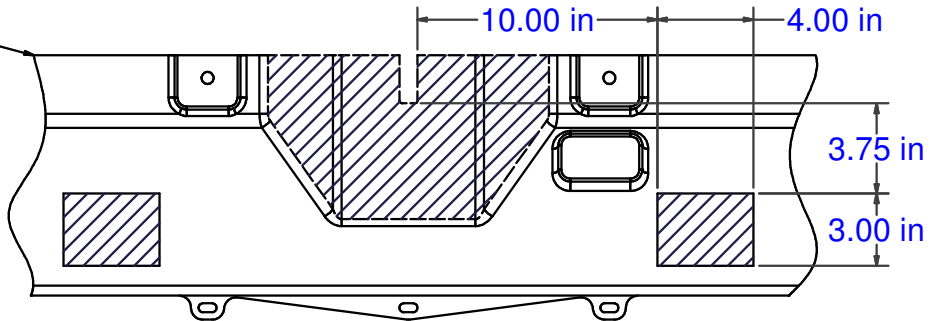

FASCIA TRIMMING DIAGRAM B
(2012 and newer models)

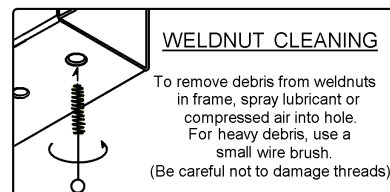
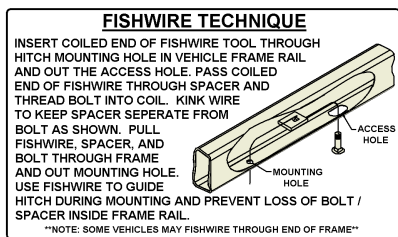

INSTALLATION STEPS

1. Remove lower plastic fascia from vehicle (Remove all push button fasteners with screw driver).
 2. Mark and trim underbody panel;
Use Trim diagram A for 2011 and older.
Use Trim diagram B for 2012 and newer.
 3. Remove the (4) existing 12mm fasteners holding the stiffening arms to the bumper beam.
 4. Slide hitch into modified fascia with tail plate above the fascia.
 5. Raise hitch and fascia to vehicle, slide hitch flanges in between bumper beam and the bumper supports aligning the holes.
 6. Loosely install 12mm fasteners with conical tooth washers on front holes.
 7. Fishwire 7/16" bolts and spacers through round support beam and into slotted hole (the fishwire will be just long enough to reach) and attach with flange nuts. (SEE FISHWIRE TECHNIQUE)
- NOTE:** The square hole spacers MUST lie in support beam length wise so the bolts penetrate far enough through the hitch.
8. Torque all 7/16" fasteners to 70 lb-ft and all 12mm fasteners to 86 lb-ft.
 9. Re-install plastic fascia with push button fasteners.

PERIODICALLY CHECK THIS RECEIVER HITCH TO ENSURE THAT ALL FASTENERS ARE TIGHT AND THAT ALL STRUCTURAL COMPONENTS ARE SOUND.

Curt Manufacturing LLC., warrants this product to be free of defects in material and/or workmanship at the time of retail purchase by the original purchaser. If the product is found to be defective, Curt Manufacturing LLC., may repair or replace the product, at their option, when the product is returned, prepaid, with proof of purchase. Alteration to, misuse of, or improper installation of this product voids the warranty. Curt Manufacturing LLC.'s liability is limited to repair or replacement of products found to be defective, and specifically excludes liability for incidental or consequential loss or damage.

*****DO NOT EXCEED VEHICLE MANUFACTURER'S RECOMMENDED TOWING CAPACITY ***.**

FRONT MOUNTED ACCESSORIES

1) Do not exceed front axle Gross Weight Rating (GAWR). Consult owners manual or specification plate located on driver's door frame. Measure gross front axle weight by placing front wheels of loaded vehicle on a scale.

WARNING: Exceeding GAWR may overload the front axle and/or suspension. This could result in **accident, property damage and personal injury.**

- 2) Reposition front mounted license plate if obstructed.
- 3) Do not obstruct vehicle lights.
- 4) Allow free air flow into grille opening.
- 5) Rear wheel traction may be reduced. This could effect handling. Reduce speed and drive with caution.
- 6) Accessories extend front of vehicle. This may reduce approach angle. Use caution when parking and maneuvering.
- 7) Do not obstruct driver view.

VEHICLE RECOVERY AND WINCHING TIPS

1) Use OEM tow hooks, recovery eyes or a clevis mount for attachment of a tow strap or winch cable.

WARNING: NEVER use a ball and/or ball mount as an anchor point for tow strap or winch cable. Severe personal injury or death could result.

- 2) Observe winch manufacturer's recommendations, cautions and warnings.
- 3) Attach return cable to tow hook or recovery eye when using a snatch block (See figure 1).

CAUTION: Do not attach return cable to winch mount. This may overload winch mount and/or front mounted receiver.

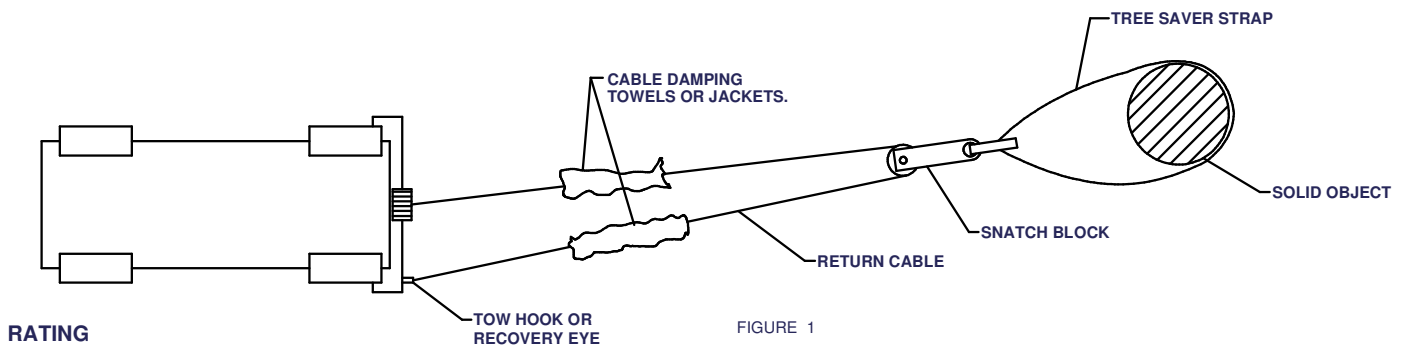

RATING

For **Maximum** line pull rating, winch cable must not exceed:

- 15 degree angle up or down from horizontal (See Figure 2).
- 45 degree angle left or right from straight ahead (See Figure 3).

CAUTION: Exceeding the maximum line pull rating may over load winch, winch mount, and/or front mounted receiver.

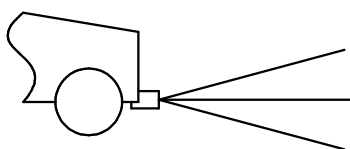

FIGURE 2

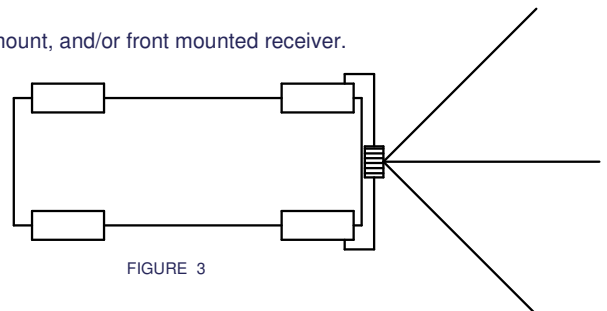

FIGURE 3