

31302**GMC SIERRA, CHEVY SILVERADO**

11/15/2012

GROSS LOAD CAPACITY WHEN USED AS A WEIGHT CARRYING HITCH: 5,000 LBS. TRAILER WEIGHT & 500 LBS. TONGUE WEIGHT.

GROSS LOAD CAPACITY WHEN USED AS A STRAIGHT LINE PULL: 9,000 LBS. MAX. LINE PULL.

***** DO NOT EXCEED VEHICLE MANUFACTURER'S RECOMMENDED TOWING CAPACITY. *****

HAVING INSTALLATION QUESTIONS? CALL TECHNICAL SUPPORT AT 1-800-798-0813

Parts List				
ITEM	QTY	PART NUMBER	DESCRIPTION	
1	1	1/2"	FISHWIRE TOOL	
2	6	1/2-13 x 1 1/4	HEX BOLT	
3	10	HFN 1213	HEX FLANGE NUT	
4	4	1/2-13 x 2 1/2 LG.	CARRIAGE BOLT	
5	4	CM-SP12	.250 x 1.00 x 2.00" SQUARE HOLE SPACER	

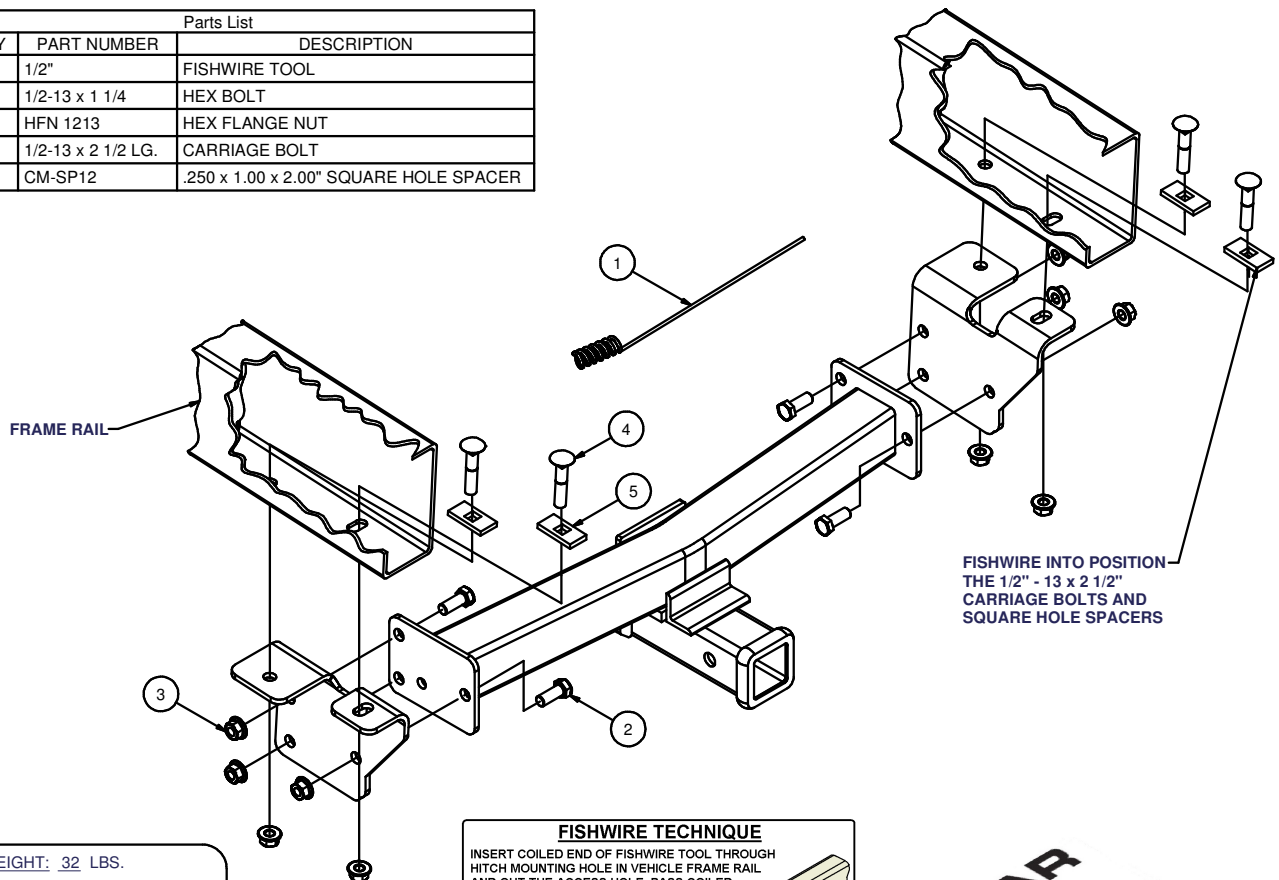
**FISHWIRE TECHNIQUE**

INSERT COILED END OF FISHWIRE TOOL THROUGH HITCH MOUNTING HOLE IN VEHICLE FRAME RAIL AND OUT THE ACCESS HOLE. PASS COILED END OF FISHWIRE THROUGH SPACER AND THREAD BOLT INTO COIL. KINK WIRE TO KEEP SPACER SEPARATE FROM BOLT AS SHOWN. PULL FISHWIRE, SPACER, AND BOLT THROUGH FRAME AND OUT MOUNTING HOLE. USE FISHWIRE TO GUIDE HITCH DURING MOUNTING AND PREVENT LOSS OF BOLT / SPACER INSIDE FRAME RAIL.

***NOTE: SOME VEHICLES MAY FISHWIRE THROUGH END OF FRAME**

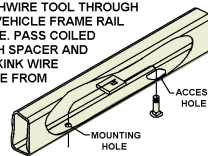

REAR
↑
FRONT

HITCH WEIGHT: 32 LBS.

INSTALL TIME

PROFESSIONAL: 60 MINUTES

NOVICE (DIY): 120 MINUTES

INSTALL NOTES:

- MAY REQUIRE CUTTING
- FISHWIRE

INSTALLATION STEPS

Note: Hitch can be installed in a "through bumper" or a "below bumper" configuration by reversing the cross member. Through bumper configuration requires a 3" square hole to be cut into the plastic fascia. Position the hole on the vehicle center line 3 1/2" below the top edge of the plastic fascia.

1. Models with tow hooks must remove the factory bolt from the underside of the frame at the forward attachment point.
2. Fishwire the 1/2" carriage bolts and spacers through the frame as shown.
3. Fasten frame brackets to frame using 1/2" flange nuts. Ensure that the brackets are loosely installed to provide adjustment for future installation steps. Reinstall factory fasteners if removal was required.
4. Install cross member between brackets and secure with the hex bolts and flange nuts provided.
5. Tighten all bolts to proper torque specifications.
6. Torque 1/2" fasteners to 110 lb-ft.

PERIODICALLY CHECK THIS RECEIVER HITCH TO ENSURE THAT ALL FASTENERS ARE TIGHT AND THAT ALL STRUCTURAL COMPONENTS ARE SOUND.

Curt Manufacturing Inc., warrants this product to be free of defects in material and/or workmanship at the time of retail purchase by the original purchaser. If the product is found to be defective, Curt Manufacturing Inc., may repair or replace the product, at their option, when the product is returned, prepaid, with proof of purchase. Alteration to, misuse of, or improper installation of this product voids the warranty. Curt Manufacturing Inc.'s liability is limited to repair or replacement of products found to be defective, and specifically excludes liability for incidental or consequential loss or damage.