

31078

## FORD SUPER DUTY

6/17/2020

GROSS LOAD CAPACITY WHEN USED AS A WEIGHT CARRYING HITCH: 5,000 LBS. TRAILER WEIGHT &amp; 500 LBS. TONGUE WEIGHT.

GROSS LOAD CAPACITY WHEN USED AS A STRAIGHT LINE PULL: 9,000 LBS. MAX. LINE PULL.

**WARNING: \*\*\* DO NOT EXCEED VEHICLE MANUFACTURER'S RECOMMENDED TOWING CAPACITY. \*\*\***FOR MORE INFORMATION LOG ONTO [WWW.CURTMFG.COM](http://WWW.CURTMFG.COM) & FOR HELPFUL TOWING TIPS LOG ONTO [WWW.HITCHINFO.COM](http://WWW.HITCHINFO.COM)  
HAVING INSTALLATION QUESTIONS? CALL TECHNICAL SUPPORT AT 1-877-287-8634

| Parts List |     |              |  |
|------------|-----|--------------|--|
| ITEM       | QTY | PART NUMBER  | DESCRIPTION                            |
| 1          | 6   | CM-SP10      | .250 x 1.00 x 2.50" SQUARE HOLE SPACER |
| 2          | 6   | 20-00062     | NUT,SER-FLANGE,1/2-13 UNC,GRD8,YZ      |
| 3          | 6   | 1_2 FISHWIRE | 1/2" FISHWIRE                          |
| 4          | 6   | 10-10272     | BOLT,CAR,1/2-13 UNC,1-3/4,GRD8,YZ      |

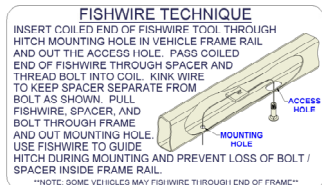

## TRIM DIAGRAM

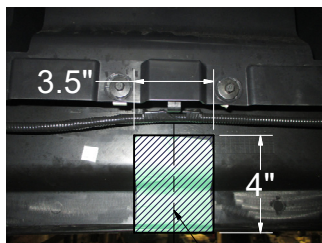

CENTER OF VEHICLE

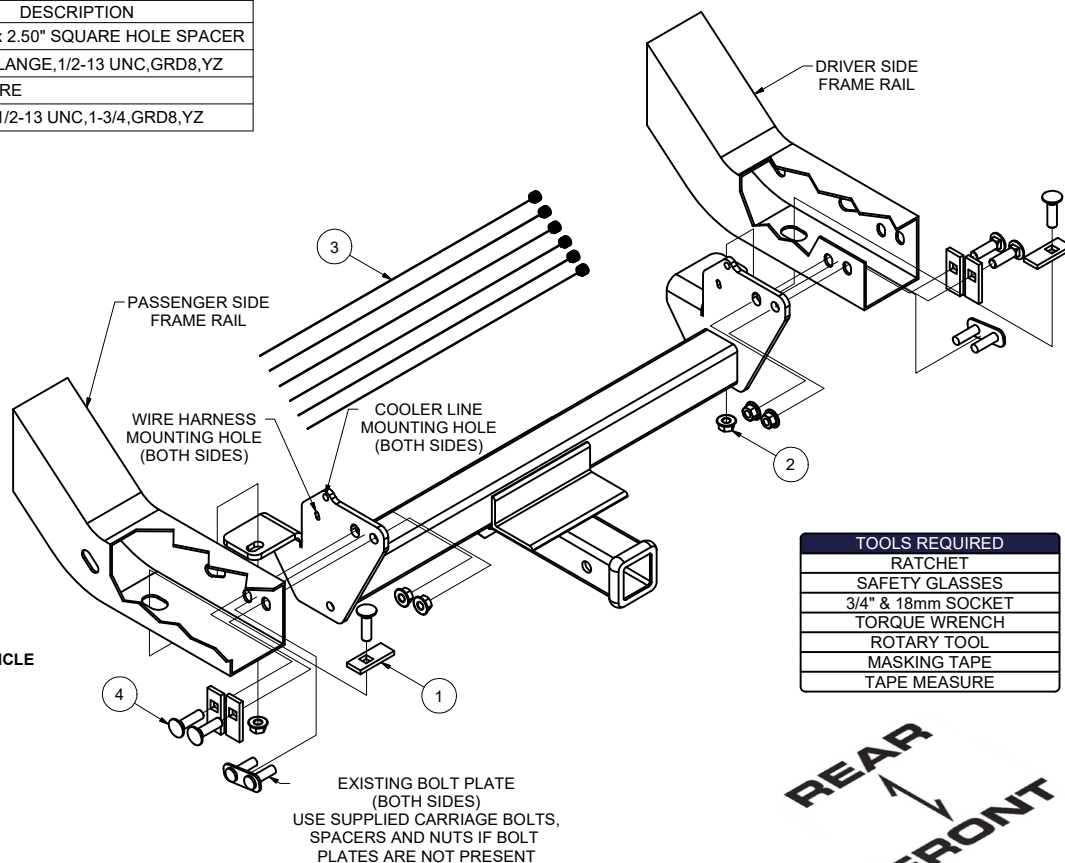

| TOOLS REQUIRED     |
|--------------------|
| RATCHET            |
| SAFETY GLASSES     |
| 3/4" & 18mm SOCKET |
| TORQUE WRENCH      |
| ROTARY TOOL        |
| MASKING TAPE       |
| TAPE MEASURE       |

HITCH WEIGHT: 32 LBS.

## INSTALL TIME

PROFESSIONAL: 30 MINUTES

NOVICE (DIY): 60 MINUTES

## INSTALL NOTES:

FISHWIRE HARDWARE

REMOVE FASCIA BRACKETS (SOME MODELS)

FASCIA TRIMMING REQUIRED

## INSTALLATION STEPS

- Use 18mm socket and ratchet to remove driver and passenger side fascia brackets and return to owner. The existing bolt plates will fall out in front of frame rails. Temporarily move electrical harness off of frame rail. Save nuts for installation later.  
**NOTE:** If oil cooler lines are present remove by unclipping attachment from frame rail.
- Fishwire (2) bolt plates removed in STEP 1 through original holes inside of frame rails. **NOTE:** If bolt plates are not present, use additionally supplied fasteners and fishwire 1/2-13 x 1 3/4" bolts and CM-SP10 spacers through holes on inside of frame rails.
- Locate center of vehicle and mark trim area with making tape. Cut marked trim area on fascia with rotary tool.  
**NOTE:** Dimensions are approximate and may be modified for an ideal fit.
- Raise side plates into position and loosely secure (4) hex flange nuts onto existing bolt plates or 1/2-13 x 1 3/4" bolts. Fishwire supplied (2) 1/2-13 x 1 3/4" carriage bolts and CM-SP10 spacers through front of driver and passenger side frame rails and out slot on bottom of frame rail. Loosely secure 1/2-13 hex flange nuts onto carriage bolts.
- Secure all hardware and torque all 1/2" hardware to 110 ft-lbs and all M12-1.75 to 86 ft-lbs. Reconnect electrical harness through hole in driver side plate.  
**NOTE:** If cooler lines are present attach to provided hole on side plate.

**PERIODICALLY CHECK THIS RECEIVER HITCH TO ENSURE THAT ALL FASTENERS ARE TIGHT AND THAT ALL STRUCTURAL COMPONENTS ARE SOUND.**



Scan for more information

CURT Manufacturing LLC., warrants this product to be free of defects in material and/or workmanship at the time of retail purchase by the original purchaser. If the product is found to be defective, CURT Manufacturing LLC., may repair or replace the product, at their option, when the product is returned, prepaid, with proof of purchase. Alteration to, misuse of, or improper installation of this product voids the warranty. CURT Manufacturing LLC.'s liability is limited to repair or replacement of products found to be defective, and specifically excludes liability for incidental or consequential loss or damage.

This product complies with safety specifications and requirements for connecting devices and towing systems of the state of New York, V.E.S.C.Regulation V-5 and SAE J684.

# FORD SUPER DUTY

**\*\*\*DO NOT EXCEED VEHICLE MANUFACTURER'S RECOMMENDED TOWING CAPACITY\*\*\*.**

## FRONT MOUNTED ACCESSORIES

1) Do not exceed front axle Gross Weight Rating (GAWR). Consult owners manual or specification plate located on driver's door frame. Measure gross front axle weight by placing front wheels of loaded vehicle on a scale.

**WARNING:** Exceeding GAWR may overload the front axle and/or suspension. This could result in **accident, property damage and personal injury.**

- 2) Reposition front mounted license plate if obstructed.
- 3) Do not obstruct vehicle lights.
- 4) Allow free air flow into grille opening.
- 5) Rear wheel traction may be reduced. This could effect handling. Reduce speed and drive with caution.
- 6) Accessories extend front of vehicle. This may reduce approach angle. Use caution when parking and maneuvering.
- 7) Do not obstruct driver view.

## VEHICLE RECOVERY AND WINCHING TIPS

1) Use OEM tow hooks, recovery eyes or a clevis mount for attachment of a tow strap or winch cable.

**WARNING: NEVER** use a ball and/or ball mount as an anchor point for tow strap or winch cable. Severe personal injury or death could result.

- 2) Observe winch manufacturer's recommendations, cautions and warnings.
- 3) Attach return cable to tow hook or recovery eye when using a snatch block (See figure 1).

**CAUTION:** Do not attach return cable to winch mount. This may overload winch mount and/or front mounted receiver.

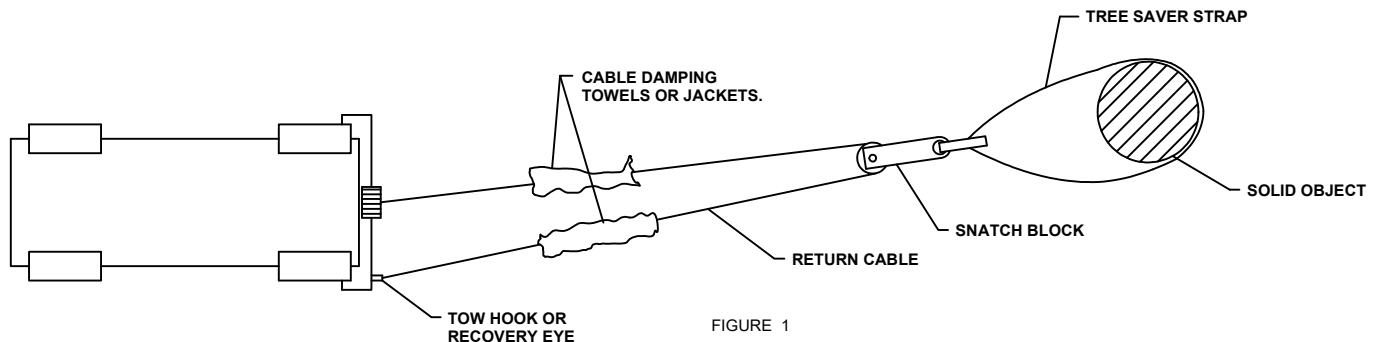

## RATING

- For **Maximum** line pull rating, winch cable must not exceed:
- 15 degree angle up or down from horizontal (See Figure 2).
  - 45 degree angle left or right from straight ahead (See Figure 3).

**CAUTION:** Exceeding the maximum line pull rating may over load winch, winch mount, and/or front mounted receiver.

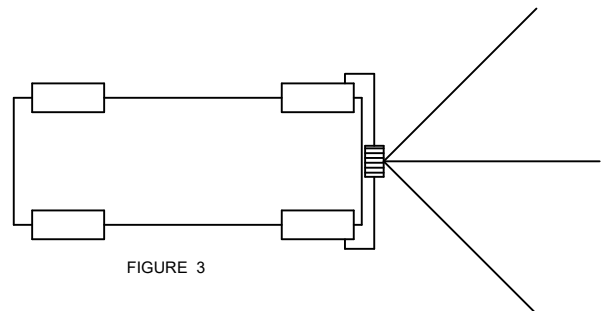
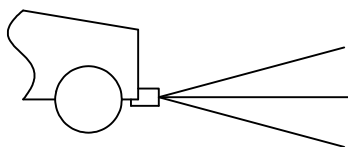





3. Locate center of vehicle and mark trim area with masking tape. Cut marked trim area on fascia with rotary tool

**NOTE:** Dimensions are approximate and may be modified for an ideal fit.

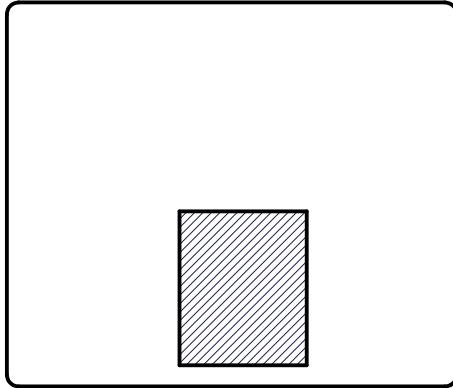

4. Raise side plates into position and loosely secure (4) hex flange nuts onto existing bolt plates or 1/2-13 x 1 3/4" bolts. Fishwire supplied (2) 1/2-13 x 1 3/4" carriage bolts and CM-SP10 spacers through front of driver and passenger side frame rails and out slot on bottom of frame rail. Loosely secure 1/2-13 hex flange nuts onto carriage bolts.

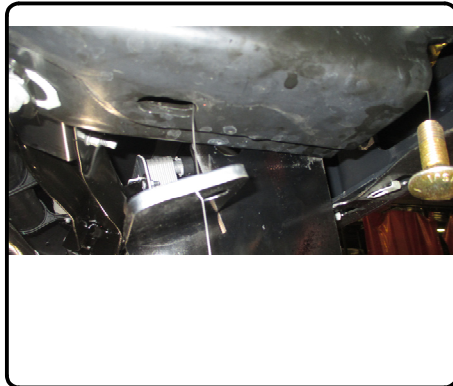

5. Secure all hardware and torque all 1/2" hardware to 110 ft-lbs and all M12-1.75 to 86 ft-lbs. Reconnect electrical harness through hole in driver side plate.

**NOTE:** If oil cooler lines are present attach to provided hole on side plate.

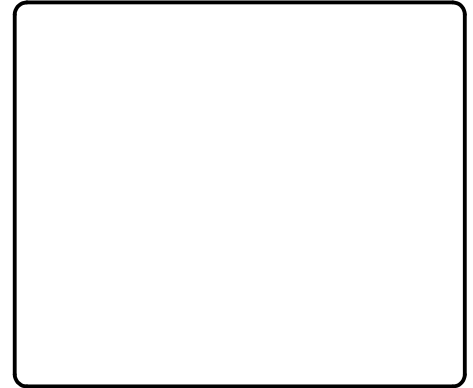

## 31078 FORD SUPER DUTY

**\*\*\*DO NOT EXCEED VEHICLE MANUFACTURER'S RECOMMENDED TOWING CAPACITY \*\*\*.**

### FRONT MOUNTED ACCESSORIES

1) Do not exceed front axle Gross Weight Rating (GAWR). Consult owners manual or specification plate located on driver's door frame. Measure gross front axle weight by placing front wheels of loaded vehicle on a scale.

**WARNING:** Exceeding GAWR may overload the front axle and/or suspension. This could result in **accident, property damage and personal injury.**

2) Reposition front mounted license plate if obstructed.

3) Do not obstruct vehicle lights.

4) Allow free air flow into grille opening.

5) Rear wheel traction may be reduced. This could effect handling. Reduce speed and drive with caution.

6) Accessories extend front of vehicle. This may reduce approach angle. Use caution when parking and maneuvering.

7) Do not obstruct driver view.

### VEHICLE RECOVERY AND WINCHING TIPS

1) Use OEM tow hooks, recovery eyes or a clevis mount for attachment of a tow strap or winch cable.

**WARNING:** **NEVER** use a ball and/or ball mount as an anchor point for tow strap or winch cable. Severe personal injury or death could result.

2) Observe winch manufacturer's recommendations, cautions and warnings.

3) Attach return cable to tow hook or recovery eye when using a snatch block (See figure 1).

**CAUTION:** Do not attach return cable to winch mount. This may overload winch mount and/or front mounted receiver.

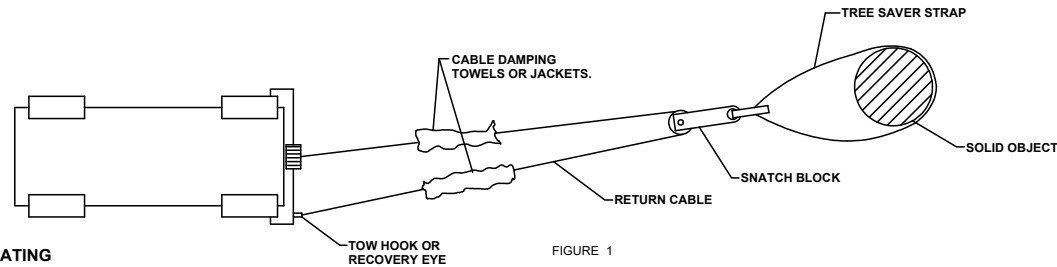

### RATING

For **Maximum** line pull rating, winch cable must not exceed:

- 15 degree angle up or down from horizontal (See Figure 2).
- 45 degree angle left or right from straight ahead (See Figure 3).

**CAUTION:** Exceeding the maximum line pull rating may over load winch, winch mount, and/or front mounted receiver.

