

31024

HONDA PILOT

12/02/2020

GROSS LOAD CAPACITY WHEN USED AS A WEIGHT CARRYING HITCH: 3,500 LBS. TRAILER WEIGHT & 350 LBS. TONGUE WEIGHT.

GROSS LOAD CAPACITY WHEN USED AS A STRAIGHT LINE PULL: 9,000 LBS. MAX. LINE PULL.

***** DO NOT EXCEED VEHICLE MANUFACTURER'S RECOMMENDED TOWING CAPACITY. *****

HAVING INSTALLATION QUESTIONS? CALL TECHNICAL SUPPORT AT 1-877-287-8634

TOOLS REQUIRED

RATCHET

6" EXTENSION

TORQUE WRENCH

SMALL SCREWDRIVER

17mm SOCKET

19mm SOCKET

3/4" SOCKET

DRILL

19/32" DRILL BIT

UTILITY KNIFE

Parts List

ITEM	QTY	PART NUMBER	DESCRIPTION
1	2	CM-SP12	.250 x 1.00 x 2.00" SQUARE HOLE SPACER
2	2	20-00062	NUT, SER-FLANGE, 1/2-13 UNC, GRD8, YZ
3	2	10-10287	BOLT, CAR, 1/2-13 UNC, 1-1/2, GRD8, YZ
4	4	10-10275	HHCS, M12x1.25, 35, CL10.9, YZ
5	4	30-00149	WASHER, S-CON, 1/2, YZ
6	2	1_2 x 30 FISHWIRE	1/2" x 30" FISHWIRE

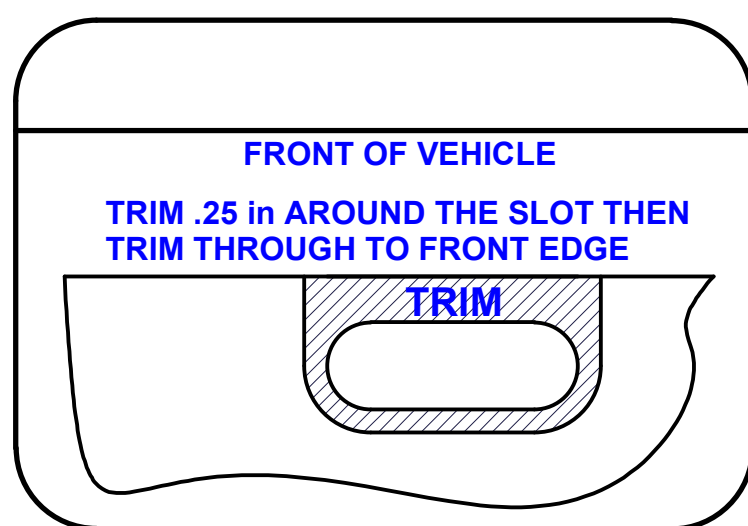

FASCIA TRIMMING DIAGRAM
TRIM FOR BOTH SIDES

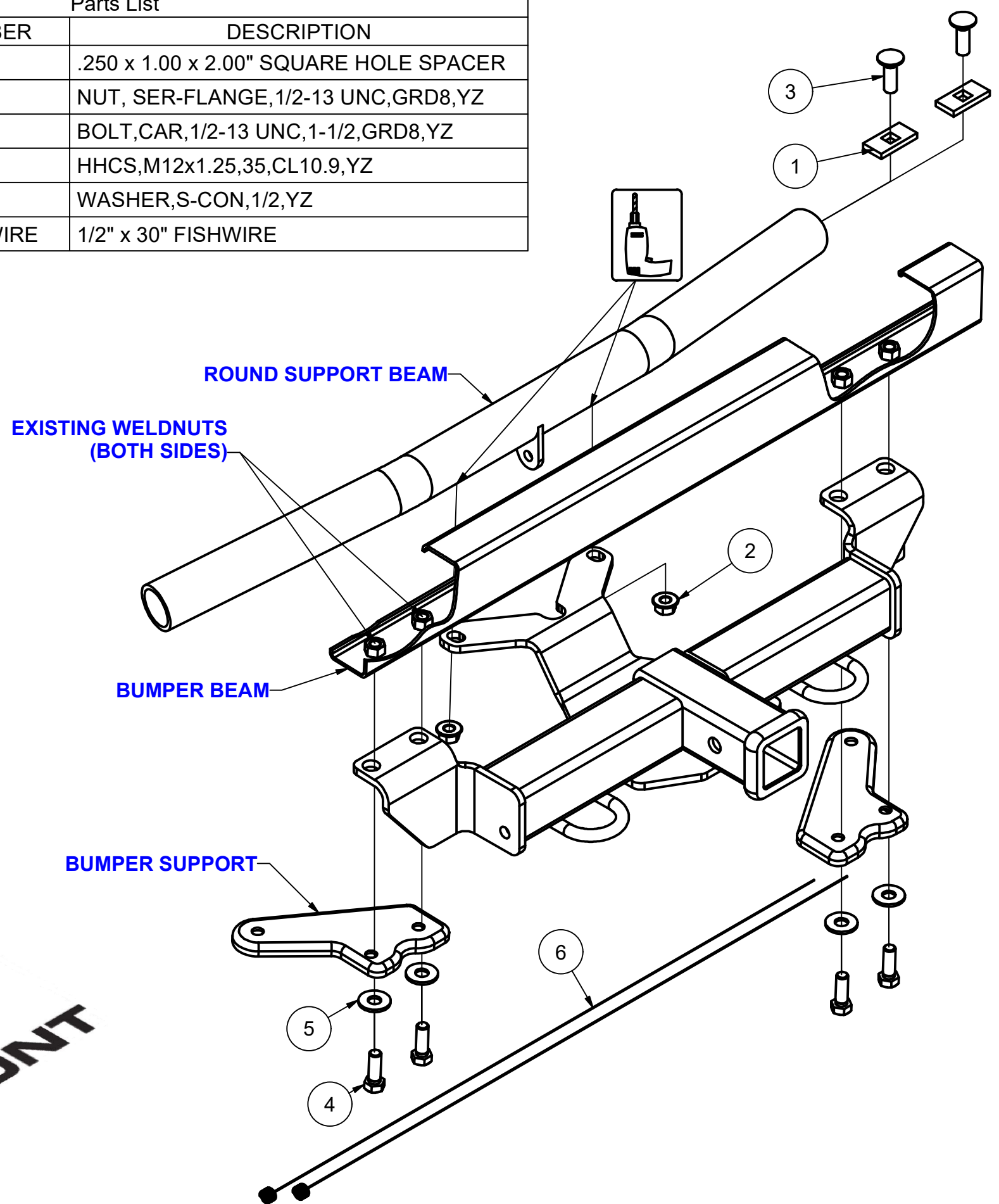

HITCH WEIGHT: 27 LBS.

INSTALL TIME

PROFESSIONAL: 60 MINUTES

NOVICE (DIY): 120 MINUTES

INSTALL NOTES:

- REMOVE / REINSTALL FASCIA
- TRIM FASCIA
- DRILLING REQUIRED

INSTALLATION STEPS

1. Remove lower plastic fascia from vehicle. (Remove all push button fasteners with screw driver)
2. Mark on the inside of the lower fascia 1/4" around the slots and then out to front edge as shown in the diagram above.
3. Remove the (4) existing 12mm fasteners holding the bumper supports to the bumper beam.
4. Slide hitch into modified fascia with tail plate above the fascia.
5. Raise hitch and fascia to vehicle, slide hitch flanges in between bumper beam and the bumper supports aligning the holes.
6. Loosely install 12mm fasteners with conical toothed washers on front holes.
7. Using the hitch as a template, mark and drill the round support beam for 1/2" hardware.
8. Fishwire 1/2" bolts and spacers through round support beam (driver's side) and out drilled holes. Attach the flange nuts. **Note:** The square hole spacers MUST lie in support beam lengthwise so the bolts penetrate far enough through the hitch.
9. Torque all 1/2" hardware to 110 lb-ft and all 12mm hardware to 86 lb-ft.
10. Reinstall plastic fascia with push button fasteners. Removed in Step 1.

PERIODICALLY CHECK THIS RECEIVER HITCH TO ENSURE THAT ALL FASTENERS ARE TIGHT AND THAT ALL STRUCTURAL COMPONENTS ARE SOUND.

Curt Manufacturing Inc., warrants this product to be free of defects in material and/or workmanship at the time of retail purchase by the original purchaser. If the product is found to be defective, Curt Manufacturing Inc., may repair or replace the product, at their option, when the product is returned, prepaid, with proof of purchase. Alteration to, misuse of, or improper installation of this product voids the warranty. Curt Manufacturing Inc.'s liability is limited to repair or replacement of products found to be defective, and specifically excludes liability for incidental or consequential loss or damage.

HONDA PILOT

*****DO NOT EXCEED VEHICLE MANUFACTURER'S RECOMMENDED TOWING CAPACITY ***.**

FRONT MOUNTED ACCESSORIES

1) Do not exceed front axle Gross Weight Rating (GAWR). Consult owners manual or specification plate located on driver's door frame. Measure gross front axle weight by placing front wheels of loaded vehicle on a scale.

WARNING: Exceeding GAWR may overload the front axle and/or suspension. This could result in **accident, property damage and personal injury.**

2) Reposition front mounted license plate if obstructed.

3) Do not obstruct vehicle lights.

4) Allow free air flow into grille opening.

5) Rear wheel traction may be reduced. This could effect handling. Reduce speed and drive with caution.

6) Accessories extend front of vehicle. This may reduce approach angle. Use caution when parking and maneuvering.

7) Do not obstruct driver view.

VEHICLE RECOVERY AND WINCHING TIPS

1) Use OEM tow hooks, recovery eyes or a clevis mount for attachment of a tow strap or winch cable.

WARNING: NEVER use a ball and/or ball mount as an anchor point for tow strap or winch cable. Severe personal injury or death could result.

2) Observe winch manufacturer's recommendations, cautions and warnings.

3) Attach return cable to tow hook or recovery eye when using a snatch block (See figure 1).

CAUTION: Do not attach return cable to winch mount. This may overload winch mount and/or front mounted receiver.

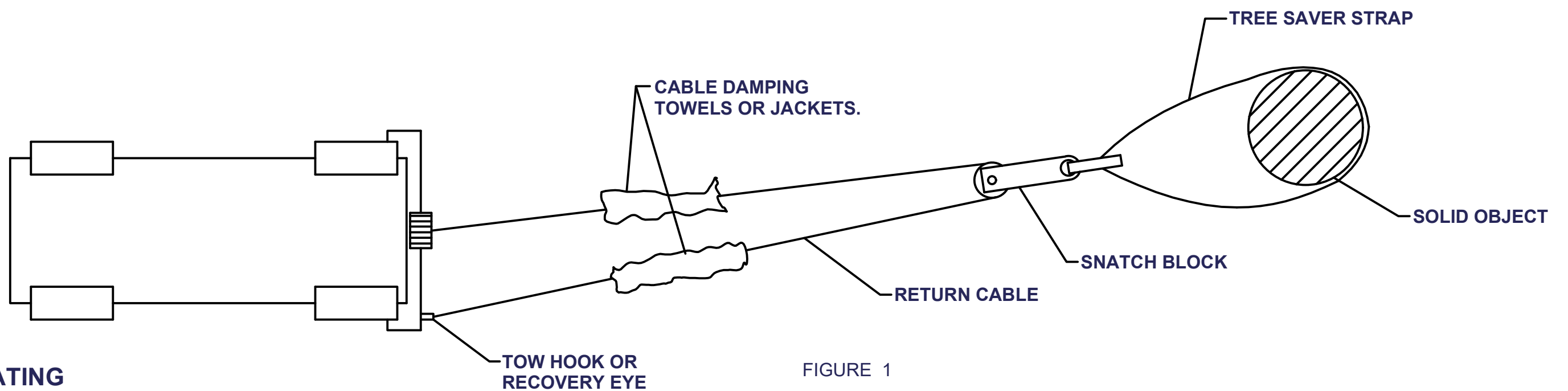

RATING

For **Maximum** line pull rating, winch cable must not exceed:

- 15 degree angle up or down from horizontal (See Figure 2).
- 45 degree angle left or right from straight ahead (See Figure 3).

CAUTION: Exceeding the maximum line pull rating may over load winch, winch mount, and/or front mounted receiver.

