

# INSTALLATION INSTRUCTIONS

**WARNING: NEVER EXCEED YOUR VEHICLE MANUFACTURER'S RECOMMENDED TOWING CAPACITY**

## BOLT-ON BIKE RACK



## USE

Never place more than two bicycles on bike rack. Secure properly and adjust for even load distribution.

This hitch-mounted bike rack is not recommended for off-road use. Do not mount on any type of trailer.

Both security clamp and tie down straps must be used per instructions. For additional bike rack stability, a third strap kit should be used. **NOTE:** Attachment point must be to a supported material such as metal. Secure bikes to bike rack with additional stretch cords.

Make sure bike tires are not directly behind exhaust pipe.

To use tilt release features, remove clevis pin & clip and tilt bike rack away from vehicle. **NOTE:** It is not recommended to tilt bike rack with bikes mounted.

## WARNINGS

Prior to installation, user must read and follow enclosed instructions. User must attach bike rack correctly to the vehicle, check its attachment before each use and inspect bike rack parts for wear.

Bike rack's attachment to the vehicle is critical and beyond the control of the manufacturer. Manufacturer and seller expressly disclaim any and all liability for personal injury, property damage or loss, whether direct, indirect or incidental, resulting from the incorrect attachment, improper use, inadequate maintenance or neglect of this bike rack.

It is the end user's responsibility to ensure that use of this product meets all local and state laws.

Refer to box for load capacity limits.

# PARTS LIST

Item#	Qty	Description
1	1	T-bracket
2	3	Flat washer, M8
3	3	Hex lock nut, M8 - 1.25
4	2	Carriage bolt, M8 - 1.25 x 45mm
5	1	Carriage bolt, M8 - 1.25 x 50mm
6	1	Cross bar
7	1	Carrier arm
8	1	Locking arm
9	4 (2 per arm)	Hex nut, M12 - 1.75
10	4 (2 per arm)	Flat washer, M12
11	2 (1 per arm)	Lock washer, M12
12	1	Upright tube
13	2	End cap
14	1	Clevis pin, 3/8" x 2"
15	2	Clip
16	2	Tie down strap
17	1	Tilt bracket
18	1	Cam lever assembly
19	1	Hex bolt, 3/4" - 10 UNC x 2 1/4"
20	1	Flat washer, 3/4"
21	1	Hex nut, 3/4" - 10 UNC

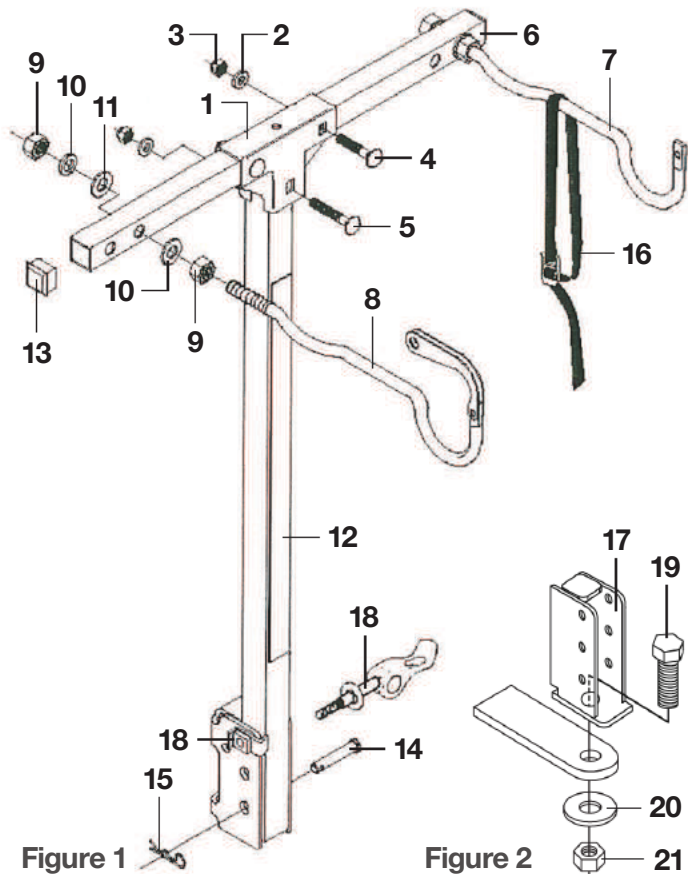

Figure 1

Figure 2

## ASSEMBLY

Center T-bracket (#1) on crossbar (#6) and secure through mating holes using carriage bolt (#4), flat washer (#2) and lock nut (#3) as shown in Figure 1. Finger tighten only.

To attach bike rack arms, thread a hex nut (#9) onto the end of each arm, to the end of the threads. Add a flat washer (#10) to each arm and insert arms into holes in cross bar see Figure 1. Secure each with a flat washer (#11), lock washer (#10) and hex nut (#9).

Slide upright tube (#12) into T-bracket. Be sure CURT label is facing out. Secure with carriage bolt (#5), flat washer (#2) and lock nut (#3). Insert plastic caps (#13) at end of each crossbar.

Tighten all nuts and bolts completely.

Turn lever clockwise until it is as snug as possible while still allowing yourself to cam it over. **NOTE:** If clamping strength is too strong, lever will not close; if so turn lever counter-clockwise 1/8" turn or until lever will close.

**NOTE:** When lever is closed it does not have to be parallel to upright tube.

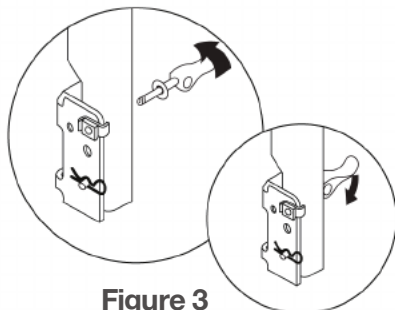

Figure 3

## MOUNT TO VEHICLE

Secure tilt bracket to hitch following Figure 2.

Align holes in bottom of upright tube with holes in tilt bracket and secure through top mating holes using cam lever assembly (Figures 1 & 3) and through bottom mating holes with a clevis pin (#14) and hitch pin (#15).

If you are not comfortable with the tightness you have achieved, hold square nut stationary with a wrench and turn lever with an adjustable wrench. Do not grab end of lever with a tool and turn.

## LOAD AND SECURE BIKES

Cover inner pedal of first bike to avoid scratching vehicle.

Place bikes on bike racks arms in designated positions, alternating the direction of the handlebars.

Check clearance; carrier must rest high enough to allow bike tires 15" of ground clearance. If not, mount bicycles under the 'V' in the frame, as with women's bikes.

Secure bikes to carrier with tie down strap.

## REMOVE BIKE RACK

To remove bike rack from tilt bracket, remove cam lever bolt and hitch pin.