

16428

FORD SUPER DUTY

10/5/2017

1 OF 3

***** DO NOT EXCEED VEHICLE MANUFACTURER'S RECOMENDED TOWING CAPACITY *****

Hardware List				
ITEM	QTY	PART NUMBER	DESCRIPTION	
1	4	5_8 - 11 x 4 1_4 HEX	HEX BOLT	
2	2	1/2-13	HANDLE NUT	
3	6	1/2 - 13 x 2 1/4	CARRIAGE BOLT	
4	4	5_8 WASHER	WASHER	
5	4	5/8-11	HEX FLANGE NUT	
6	8	CM-SP136	.313" x 1.00 x 2.00" U-SHAPE SPACER	
7	8	CM-SP27	.188 x 1.00 x 2.00" U-SHAPE SPACER	
8	2	CM-SP34	.188 x 1.50 x 3.00" ROUND HOLE SPACER	
9	2	1/2 - 13 x 2"	CARRIAGE BOLT	
10	8	HFN 1213	HEX FLANGE NUT	
11	2	1/2-13 x 2 1/4	HEX BOLT	
12	6	CM-SP33	.250 x 1.50 x 2.00" SQUARE HOLE SPACER	
13	2	1/2"	LOCK WASHER	
14	2	16428-SP	SPACER	

TOOLS REQUIRED
RATCHET
3/4" & 15/16" SOCKET
TORQUE WRENCH
CENTER PUNCH
DRILL
1/8" & 9/16" DRILL BITS
TAPE MEASURE

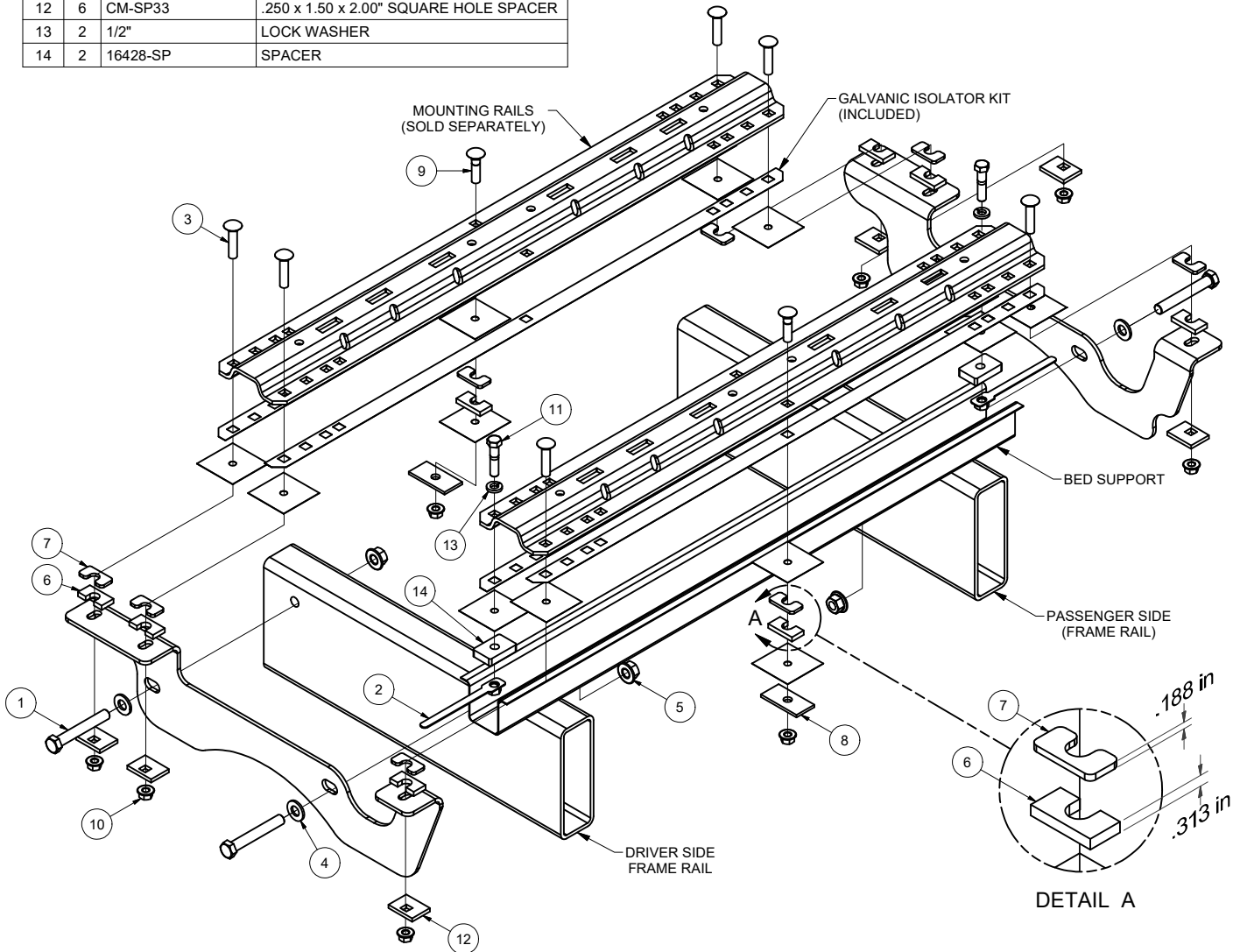

HITCH WEIGHT: 25 LBS.

INSTALL TIME

PROFESSIONAL: 90 MINUTES

NOVICE (DIY): 180 MINUTES

INSTALL NOTES:

- LOWER SPARE TIRE
- NO FRAME DRILLING REQUIRED

Curt Manufacturing LLC., warrants this product to be free of defects in material and/or workmanship at the time of retail purchase by the original purchaser. If the product is found to be defective, Curt Manufacturing LLC., may repair or replace the product, at their option, when the product is returned, prepaid, with proof of purchase. Alteration to, misuse of, or improper installation of this product voids the warranty. Curt Manufacturing LLC.'s liability is limited to repair or replacement of products found to be defective, and specifically excludes liability for incidental or consequential loss or damage.



WARNING:

- Do not install mounting rails over plastic bed liners. Plastic liners must be trimmed for metal to metal contact. (Mounting rails may be installed on spray on liner.)
- Use only supplied fasteners for installation.
- Before installing mounting rails and hitch, measure to be sure there will be enough clearance between the truck and trailer to allow for turns.

Installation Instructions:

1. Lower and remove the spare tire and exhaust heat shield for ease of installation.

WARNING: When drilling holes be aware of potential risks to vehicle components and make appropriate safe guards to protect them from damage.

Note: On vehicles with an aluminium bed, it will be required that all steel components be isolated from aluminum with the Galvanic Isolator kit supplied.

2. Temporarily install the side plates by placing (4) 5/8" hex bolts and washers through the side plates and through the holes in the frame rails and secure with hex flange nuts provided. Using a center punch, mark the rearward locations (Row 1 on page 3) of the center of the mounting rail hole of the side plate locations in the bottom of the bed. Place the rearward mounting rail in the bed of the truck and check to see that Row 1 aligns with the center punch marks. Center punch Row 2 holes and check alignment with center of bed support. Adjust center marks side to side as required to align Row 2 with center of bend support. Move rail out of the way and drill 1/8" holes in Row 1 mounting locations. Check mounting brackets to make sure they are aligned. Drill 1/8" holes in Row 2 mounting locations.
3. Remove the mounting rail and enlarge the 1/8" holes to 9/16" in Rows 1 and 2. Reinstall the side plates and mounting rail with the Row 1 1/2" x 2" carriage bolts, CM-SP27, and CM-SP136 spacers. Place the spacers between the bracket or mounting rail and the bed to prevent the bed from collapsing when the bolts are tightened. Loosely install the supplied 1/2" flange nuts.
4. Install 1/2" x 2" hex bolts and 1/2" lock washers through Row 2 installation holes. Install 16428-SP spacers and 1/2" handles nuts into ends of bed supports as shown and loosely tighten 1/2" hex bolts.
- 5a. Place the unassembled 5th wheel saddles / slider / goose into the already installed mounting rail. Position the forward mounting rail with saddles / slider / goose by inserting the tabs into the mounting rail and pushing the mounting rail tight towards the other mounting rail. Ensure that the mounting rail is centered between the box sides on the length of the truck box floor. This will position the mounting rail in the correct location and ensure that the 5th wheel will have a snug fit to the truck. Drill the 1/8" holes in Row 3 and 4.

Note: If more than one hitch product will be used with the rails then both should be used at the same time to align the second rail. This will ensure that one product does not compromise the fit of the other.

If hitch attachment is not available use step 4b for rear mounting rail placement

- 5b. Place the forward mounting rail in the bed of the truck and place 22" on center from forward to rear rails. Center the rail side to side. Center punch the Row 4 hole locations. This process is to verify that the hole locations are correct due to bed support location variances. When aligned, drill the 1/8" holes in Row 3 and 4.
6. Enlarge the 1/8" holes to 9/16". Install the mounting rail with the 1/2" x 2" carriage bolts, CM-SP27, and CM-SP136 spacers. Place the spacers between the bracket or mounting rail and the bed to prevent the bed from collapsing when the bolts are tightened. Loosely install the supplied 1/2" flange nuts.
7. Install the 1/2" x 1-3/4" carriage bolt in the center hole of the mounting rails as shown on sheet 1. Place CM-SP27 and CM-136 spacers between the rail and the bed, and secure the bolt with a CM-SP34 spacer and 1/2" flange nut on the bottom.
8. Torque the fasteners in the following sequence:
 - a) mounting rails to the frame brackets to 110 lb-ft.
 - b) frame brackets to the truck frame to 210 lb-ft.
9. Reinstall the heat shield and spare tire removed in step 1.

WARNING:

- Do not install mounting rails over plastic bed liners. Plastic liners must be trimmed for metal to metal contact. (Mounting rails may be installed on spray on liner.)
- Use only supplied fasteners for installation.
- Before installing mounting rails and hitch, measure to be sure there will be enough clearance between the truck and trailer to allow for turns.

RAIL LOCATION DIAGRAM

!!IMPORTANT!!
 SYSTEM MAY NOT WORK WITH
 2003 AND EARLIER COMPETITOR
 PRODUCTS

