

16415

CHEVROLET / GMC 1500

10/1/2019

1 OF 3

***** DO NOT EXCEED VEHICLE MANUFACTURER'S RECOMENDED TOWING CAPACITY *****

Hardware List			
ITEM	QTY	PART NUMBER	DESCRIPTION
1	18	20-00062	NUT, SER-FLANGE, 1/2-13 UNC, GRD8, YZ
2	10	10-10288	BOLT, CAR, 1/2-13 UNC, 2, GRD8, YZ
3	10	CM-SP136	.313" x 1.00 x 2.00" U-SHAPE SPACER
4	10	CM-SP33	.250 x 1.50 x 2.00" SQUARE HOLE SPACER
5	2	20-00106	NUT, SER-FLANGE, 3/4-10 UNC, GRD8, YZ
6	2	30-00152	WASHER, FLAT, 3/4, YZ
7	2	10-10607	HHCS, 3/4-10 UNC, 4-1/2, GRD8, YZ
8	2	CM-1208-UBS	1/2-13 x 4 1/8 x 6 x 1 1/2 SQ U-BOLT
9	2	CM-1204-UBS	1/2-13 x 4 1/4 x 6 7/8 x 1 1/2 SQ U-BOLT
10	10	CM-SP27	.188 x 1.00 x 2.00" U-SHAPE SPACER
11	2	CM-SP58	.250 x 3.00 x 4.00" SPACER
12	2	16415-TS	TUBE SPACER

TOOLS REQUIRED
RATCHET
3/4" & 15/16" SOCKET
TORQUE WRENCH
CENTER PUNCH
DRILL
1/8" & 9/16" DRILL BITS
TAPE MEASURE

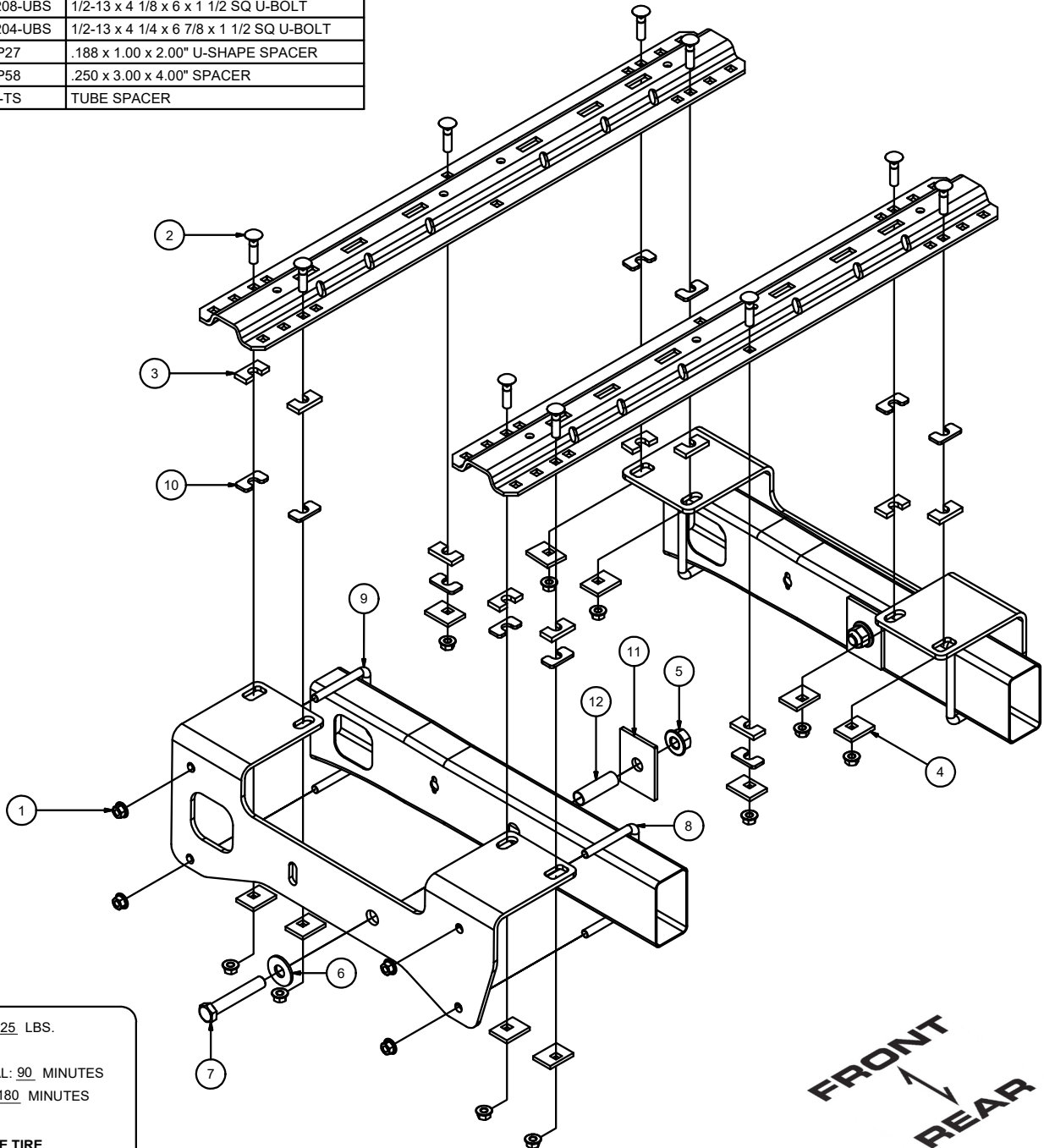

HITCH WEIGHT: 25 LBS.

INSTALL TIME

PROFESSIONAL: 90 MINUTES

NOVICE (DIY): 180 MINUTES

INSTALL NOTES:

- LOWER SPARE TIRE
- NO FRAME DRILLING REQUIRED

Curt Manufacturing LLC., warrants this product to be free of defects in material and/or workmanship at the time of retail purchase by the original purchaser. If the product is found to be defective, Curt Manufacturing LLC., may repair or replace the product, at their option, when the product is returned, prepaid, with proof of purchase. Alteration to, misuse of, or improper installation of this product voids the warranty. Curt Manufacturing LLC.'s liability is limited to repair or replacement of products found to be defective, and specifically excludes liability for incidental or consequential loss or damage.

WARNING:

- Do not install mounting rails over plastic bed liners. Plastic liners must be trimmed for metal to metal contact. (Mounting rails may be installed on spray on liner.)
- Use only supplied fasteners for installation.
- Before installing mounting rails and hitch, measure to be sure there will be enough clearance between the truck and trailer to allow for turns.

- 1) Place one mounting rail in the box of the truck, using your tape measure, center the rail on the truck box floor and the proper distance from the rear edge of the truck box as shown on the "rail location diagram" page.

****BE SURE TO COMPENSATE FOR THE THICKNESS OF THE SPRAY-IN BED LINER IF PRESENT****

- 2) Using a center punch, mark the holes as per the rail location diagram. Move the mounting rail out of the way and drill each position with a 1/8" drill bit.
- 3) Temporarily position the side plate on the side of the frame and check that the 1/8" drilled holes align with the slots of the side plate. Remove the side plate from the vehicle.

NOTE: Move any electrical or braking components that may be trapped between the frame and side plates.

- 4) Enlarge the 1/8" drill holes to the 9/16" with a step drill.

NOTE: Depending on the year and box size, the brake cable hanger may need to be attached through the side plate on the driver side. To do this, remove the bracket from the truck and tip the bracket, thread through the long slot and rotate into position. Removing the brake lines from the bracket will be required to do this. To reinstall the brake lines, push the bracket further through the plate and collect the lines with the bracket. Be sure lines are in original position on the bracket.

- 5) Place u-bolts, 16415-TS and 3/4" hex bolt into position on frame, fasten the side plate to the side of the frame using the appropriate hardware. Tighten hand tight. Grind away excess threads to avoid vehicle contact.
- 6) Reposition the mounting rail over the holes and fasten the mounting rail to the side plates using the supplied carriage bolts. Use the supplied spacers as needed between the side plates or mounting rails and the truck box to ensure surface to surface contact and to eliminate "rib crush" of the bed.
- 7) Place the unassembled 5th wheel / roller / gooseneck hitch into the already installed mounting rail. Position the second mounting rail with the 5th wheel / roller / gooseneck hitch by inserting the tabs into the mounting rail and pushing the mounting rail tight towards the other mounting rail. Ensure that the mounting rail is centered on the truck box floor. This will position the rail in the correct location and ensure that the 5th wheel will have a snug fit to the truck.

NOTE: If more than one hitch product will be used with the mounting rails then both should be used at the same time to align the second mounting rail. This will ensure that one product does not compromise the fit of the other.

- 8) Repeat steps 2, 4, 6 and 7
- 9) Starting with the carriage bolts that fasten the rails to the frame bracket, torque all the nuts. Torque all 1/2" fasteners to 110 lb-ft (excluding the U-bolts that need to be torqued to 75 lb-ft) and all 3/4" fasteners to 250 lb-ft. Ensure not to crush frame rail when tightening fasteners.

WARNING:

- Do not install mounting rails over plastic bed liners. Plastic liners must be trimmed for metal to metal contact.
(Mounting rails may be installed on spray on liner.)
- Use only supplied fasteners for installation.
- Before installing mounting rails and hitch, measure to be sure there will be enough clearance between the truck and trailer to allow for turns.

