

**15703****CHEVY SILVERADO & GMC SIERRA 2500 & 3500 HD****5/12/2020**

GROSS LOAD CAPACITY WHEN USED AS A WEIGHT CARRYING HITCH: 18,000 LBS. TRAILER WEIGHT & 2,700 LBS. TONGUE WEIGHT.  
 GROSS LOAD CAPACITY WHEN USED AS A WEIGHT DISTRIBUTION HITCH: 18,000 LBS. TRAILER WEIGHT & 2,700 LBS. TONGUE WEIGHT

**\*\*\* DO NOT EXCEED VEHICLE MANUFACTURER'S RECOMMENDED TOWING CAPACITY. \*\*\***

HAVING INSTALLATION QUESTIONS? CALL TECHNICAL SUPPORT AT 1-877-287-8634

Parts List			
ITEM	QTY	PART NUMBER	DESCRIPTION
1	4	20-00104	NUT,SER-FLANGE,9/16-12 UNC,GRD8,YZ
2	2	CM-SP70	.313 x 1.00 x 2.50" 9/16" SQUARE HOLE SPACER
3	4	10-10328	BOLT,CAR,9/16-12 UNC,1-3/4,GRD8,YZ
4	2	CM-SP73	.313 x 1.25 x 2.00" 9/16" SQUARE HOLE SPACER
5	4	10-10281	BOLT,CAR,7/16-14 UNC,1-1/4,GRD8,YZ
6	4	20-00103	NUT,SER-FLANGE,7/16-14 UNC,GRD8,YZ
7	2	15703-MS	.313" MOUNTING STRAP

**TOOLS REQUIRED**

RATCHET WRENCH  
 TORQUE WRENCH  
 21mm SOCKET  
 11/16" SOCKET  
 7/8" SOCKET

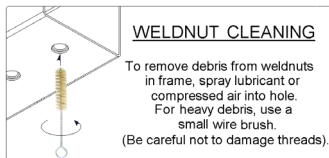

HITCH WEIGHT: 74 LBS.

**INSTALL TIME**

PROFESSIONAL: 30 MINUTES

NOVICE (DIY): 60 MINUTES

**INSTALL NOTES:**

- MAY REQUIRE DRILLING

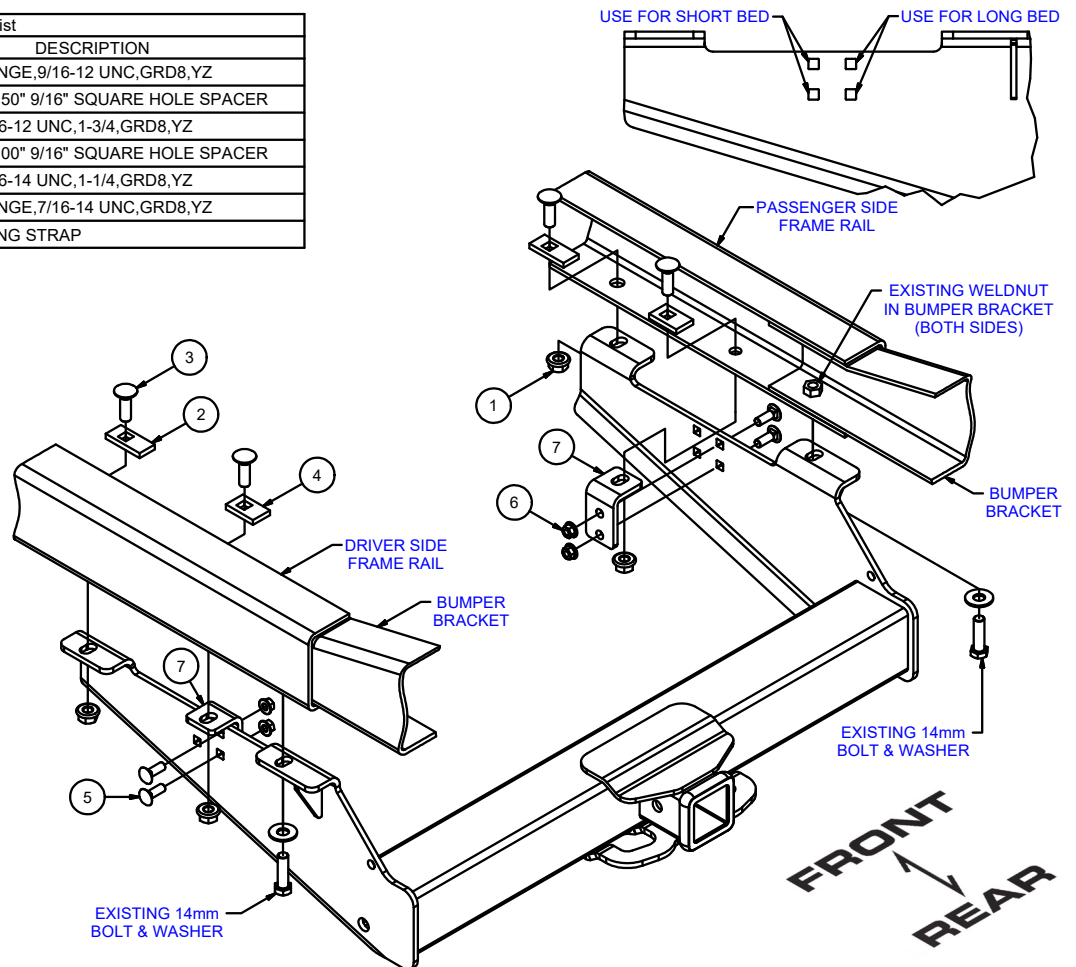
**INSTALLATION STEPS**

1. Remove spare tire for ease of installation.
2. Remove the 14mm bolts and washers that are located in the rear most bottom section of each frame rail. Save bolts for Step (3).
3. Raise hitch into position aligning the rear most holes in the hitch with 14mm weldnuts which the bolts were previously removed. Loosely attach hitch using 14mm hardware which was removed in Step (1)
4. Place 9/16" bolts and SP-70 spacers into forward-most mounting holes in the truck frame.
5. Install mounting straps to the inside of hitch side plates using two 7/16" bolts per side. These should be positioned to line up with holes in the vehicle frame rail, see diagram above for bed configurations.
6. Place the remaining SP-73 spacers and 9/16 bolts into position into center mouning locations. Attach to the mounting strap using 9/16" flange nuts.
7. Torque all 7/16" fasteners to 70 ft-lbs.  
 Torque all 9/16" fasteners to 150 ft-lbs.  
 Torque all 14mm fasteners to 154 ft-lbs.
8. Reinstall spare tire.

**PERIODICALLY CHECK THIS RECEIVER HITCH TO ENSURE THAT ALL FASTENERS ARE TIGHT AND THAT ALL STRUCTURAL COMPONENTS ARE SOUND.**

Curt Manufacturing LLC., warrants this product to be free of defects in material and/or workmanship at the time of retail purchase by the original purchaser. If the product is found to be defective, Curt Manufacturing LLC., may repair or replace the product, at their option, when the product is returned, prepaid, with proof of purchase. Alteration to, misuse of, or improper installation of this product voids the warranty. Curt Manufacturing LLC.'s liability is limited to repair or replacement of products found to be defective, and specifically excludes liability for incidental or consequential loss or damage.