

15460

CHEVROLET & GMC 2500/3500

5/7/2020

GROSS LOAD CAPACITY WHEN USED AS A WEIGHT CARRYING HITCH: 17,000 LBS. TRAILER WEIGHT & 2,550 LBS. TONGUE WEIGHT. GROSS LOAD CAPACITY WHEN USED AS A WEIGHT DISTRIBUTION HITCH: 17,000 LBS. TRAILER WEIGHT & 2,550 LBS. TONGUE WEIGHT

DO NOT EXCEED VEHICLE MANUFACTURER'S RECOMMENDED TOWING CAPACITY.

HAVING INSTALLATION QUESTIONS? CALL TECHNICAL SUPPORT AT 1-877-287-8634

Parts List			
ITEM	QTY	PART NUMBER	DESCRIPTION
1	4	10-10278	BOLT,CAR,1/2-13 UNC,1-1/4,GRD8,YZ
2	6	20-00062	NUT,SER-FLANGE,1/2-13 UNC,GRD8,YZ
3	2	CM-SP1	.250 x 1.50 x 2.00" SQUARE HOLE SPACER
4	2	10-10272	BOLT,CAR,1/2-13 UNC,1-3/4,GRD8,YZ
5	2	10-10449	HHCS,M14x2,45,CL10.9,YZ
6	2	30-00164	WASHER,S-CON,9/16,YZ
7	2	15460-ST	.250" STRAP PLATE

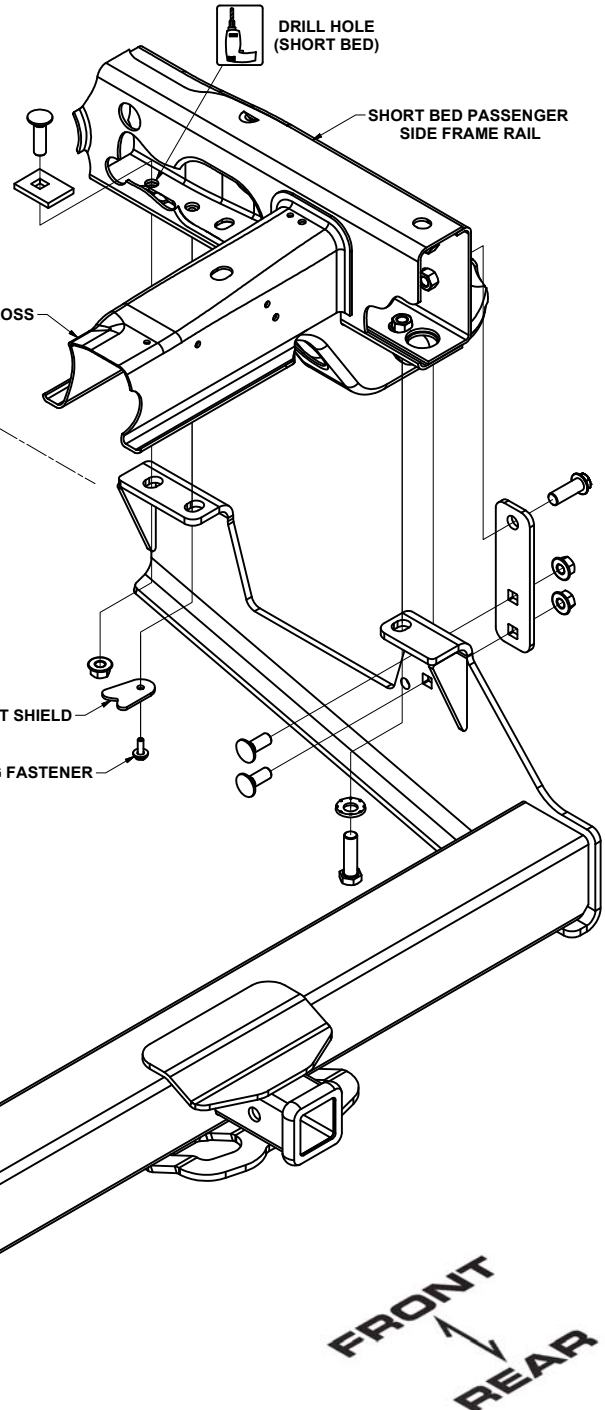

SHORT BED INSTALLATION

LONG BED INSTALLATION

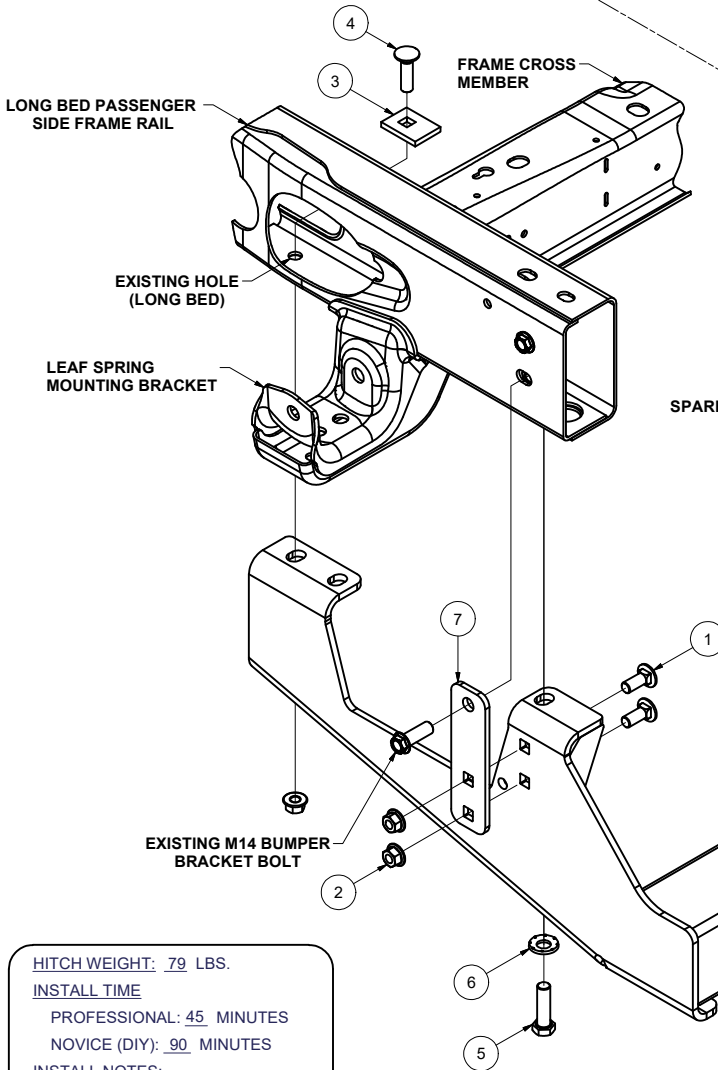

HITCH WEIGHT: 79 LBS.

INSTALL TIME

PROFESSIONAL: 45 MINUTES

NOVICE (DIY): 90 MINUTES

INSTALL NOTES:

- LOWER SPARE
- DRILLING REQUIRED (SHORT BED)

PERIODICALLY CHECK THIS RECEIVER HITCH TO ENSURE THAT ALL FASTENERS ARE TIGHT AND THAT ALL STRUCTURAL COMPONENTS ARE SOUND.

Curt Manufacturing Inc., warrants this product to be free of defects in material and/or workmanship at the time of retail purchase by the original purchaser. If the product is found to be defective, Curt Manufacturing Inc., may repair or replace the product, at their option, when the product is returned, prepaid, with proof of purchase. Alteration to, misuse of, or improper installation of this product voids the warranty. Curt Manufacturing Inc.'s liability is limited to repair or replacement of products found to be defective, and specifically excludes liability for incidental or consequential loss or damage.

15460

CHEVROLET & GMC 2500/3500

DO NOT EXCEED VEHICLE MANUFACTURER'S RECOMMENDED TOWING CAPACITY.
HAVING INSTALLATION QUESTIONS? CALL TECHNICAL SUPPORT AT 1-877-287-8634

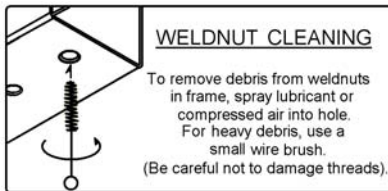

TOOLS REQUIRED
RATCHET
TORQUE WRENCH
10" EXTENSION
21mm SOCKET
3/4" SOCKET
13mm SOCKET
17/32" DRILL BIT
DRILL

INSTALLATION STEPS

LONG BED INSTALLATION

1. Lower spare tire for ease of installation.
2. If present, remove existing 14mm fasteners from the end of each frame rail and return to vehicle owner.
3. Remove the lower 14mm bumper bracket bolt from the side of each frame rail and retain for reinstallation.
4. Raise hitch into position and secure to the rear-most weldnut in the frame rail using M14-2 x 45 hex bolts and 9/16" conical toothed washers.
5. Install 1/2"-13 x 1 3/4" carriage bolts and CM-SP1 spacers through existing holes, as shown. Secure hitch to carriage bolts using 1/2" flange nuts.
6. Attach the 15460-ST straps to the side plates using 1/2"-13 x 1 1/4" carriage bolts and 1/2"-13 flange nuts. Secure the straps to the outside of the frame rails using the 14mm bolt removed in Step (3).
7. Torque all 14mm fasteners to 126 ft-lbs, and all 1/2" fasteners to 110 ft-lbs.
8. Reinstall spare tire.

SHORT BED INSTALLATION

1. Lower spare tire for ease of installation.
2. If present, remove existing 14mm fasteners from the end of each frame rail and return to vehicle owner.
3. Remove the lower 14mm bumper bracket bolt from the side of each frame rail and retain for reinstallation.
4. Remove passenger side spare tire heat shield by removing (2) 7mm fasteners. Retain heat shield and fasteners for reinstallation.
5. Raise hitch into position and secure to the rear-most weldnut in the frame rail using M14-2 x 45 hex bolts and 9/16" conical toothed washers.
6. Using hitch as a template, drill the forward-most hole for 1/2" fasteners on the driver and passenger side frame rails. **NOTE:** If needed mark the drill holes and remove hitch prior to drilling.
7. Install 1/2"-13 x 1 3/4" carriage bolts and CM-SP1 spacers through drilled holes, as shown. Secure hitch to carriage bolts using 1/2" flange nuts.
8. Reinstall spare tire heat shield and fasteners removed in Step (4). The passenger hitch side plate will be sandwiched between the heat shield and frame rail.
9. Attach the 15460-ST straps to the side plates using 1/2"-13 x 1 1/4" carriage bolts and 1/2"-13 flange nuts. Secure the straps to the outside of the frame rails using the 14mm bolt removed in Step (3).
10. Torque all 14mm fasteners to 126 ft-lbs, and all 1/2" fasteners to 110 ft-lbs. and 7mm fastener to 16 ft-lbs.
11. Reinstall spare tire.

PERIODICALLY CHECK THIS RECEIVER HITCH TO ENSURE THAT ALL FASTENERS ARE TIGHT AND THAT ALL STRUCTURAL COMPONENTS ARE SOUND.

Curt Manufacturing Inc., warrants this product to be free of defects in material and/or workmanship at the time of retail purchase by the original purchaser. If the product is found to be defective, Curt Manufacturing Inc., may repair or replace the product, at their option, when the product is returned, prepaid, with proof of purchase. Alteration to, misuse of, or improper installation of this product voids the warranty. Curt Manufacturing Inc.'s liability is limited to repair or replacement of products found to be defective, and specifically excludes liability for incidental or consequential loss or damage.