

GROSS LOAD CAPACITY WHEN USED AS A WEIGHT CARRYING HITCH: 10,000 LBS. TRAILER WEIGHT & 1,000 LBS. TONGUE WEIGHT.  
GROSS LOAD CAPACITY WHEN USED AS A WEIGHT DISTRIBUTION HITCH: 12,000 LBS. TRAILER WEIGHT & 1,200 LBS. TONGUE WEIGHT  
\*\*\*DO NOT EXCEED VEHICLE MANUFACTURER'S RECOMMENDED TOWING CAPACITY.\*\*\*

Parts List			
ITEM	QTY	PART NUMBER	DESCRIPTION
1	4	20-00062	NUT, SER-FLANGE, 1/2-13 UNC, GRD8, YZ
2	4	10-10278	BOLT, CAR, 1/2-13 UNC, 1-1/4, GRD8, YZ
3	2	10-10038	HHCS, 5/8-11 UNC, 1-1/2, GRD8
4	2	30-00131	WASHER, FLAT, 5/8, YZ
5	2	20-00105	NUT, SER-FLANGE, 5/8-11 UNC, GRD8, YZ

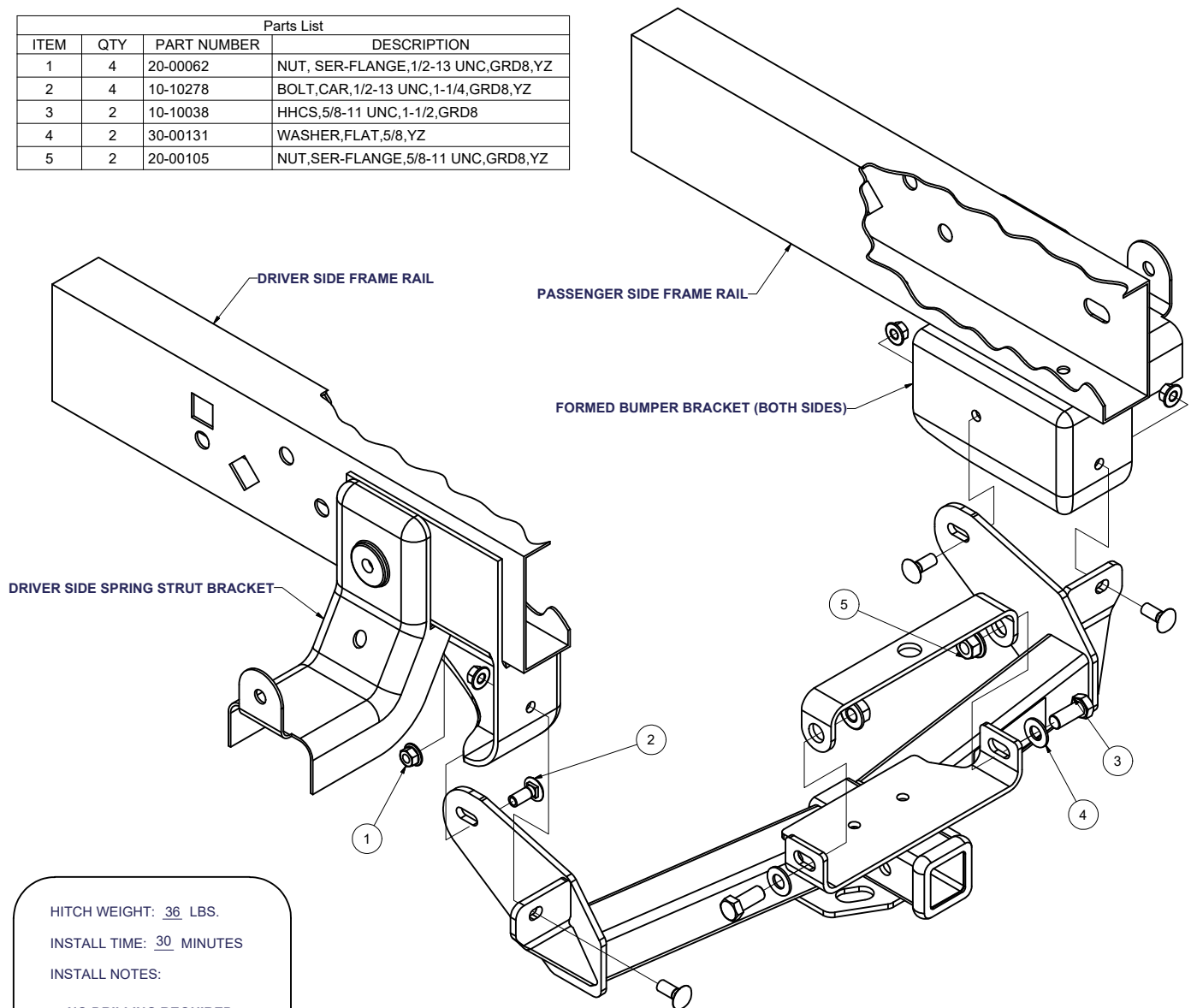

HITCH WEIGHT: 36 LBS.  
INSTALL TIME: 30 MINUTES  
INSTALL NOTES:  
**NO DRILLING REQUIRED**

### **INSTALLATION STEPS**

NOTE: If necessary, loosen (4) bumper bolts for improved hitch alignment.

- 1) Raise hitch into position between frame rails.
- 2) Install 5/8" fasteners into bumper with loops as shown.
- 3) Install remaining 1/2" fasteners as shown into each bumper bracket.
- 4) Torque all 5/8" fasteners to 210 lb-ft and all 1/2" fasteners to 110 lb-ft.

PERIODICALLY CHECK THIS RECEIVER HITCH TO ENSURE THAT ALL FASTENERS ARE TIGHT AND THAT ALL STRUCTURAL COMPONENTS ARE SOUND.