

14010

CHEVROLET / GMC 2500 / 3500 (LONG BOX)

08/14/2020

PAGE 1 OF 2

GROSS LOAD CAPACITY WHEN USED AS A WEIGHT CARRYING HITCH: 10,000 LBS. TRAILER WEIGHT & 1,000 LBS. TONGUE WEIGHT.
GROSS LOAD CAPACITY WHEN USED AS A WEIGHT DISTRIBUTION HITCH: 12,000 LBS. TRAILER WEIGHT & 1,200 LBS. TONGUE WEIGHT

*****DO NOT EXCEED VEHICLE MANUFACTURER'S RECOMMENDED TOWING CAPACITY.*****

HAVING INSTALLATION QUESTIONS? CALL TECHNICAL SUPPORT AT 1-877-287-8634

Parts List			
ITEM	QTY	PART NUMBER	DESCRIPTION
1	2	10-10272	BOLT,CAR,1/2-13 UNC,1-3/4,GRD8,YZ
2	4	10-10278	BOLT,CAR,1/2-13 UNC,1-1/4,GRD8,YZ
3	2	10-10449	HHCS,M14x2,45,CL10.9,YZ
4	6	20-00062	NUT, SER-FLANGE,1/2-13 UNC,GRD8,YZ
5	2	30-00164	WASHER,S-CON,9/16,YZ
6	2	CM-SP1	.250 x 1.50 x 2.00" SQUARE HOLE SPACER
7	2	14010-ST	.250" STRAP PLATE

TOOLS REQUIRED
RATCHET
TORQUE WRENCH
10" EXTENSION
10mm & 21mm SOCKET
3/4" SOCKET

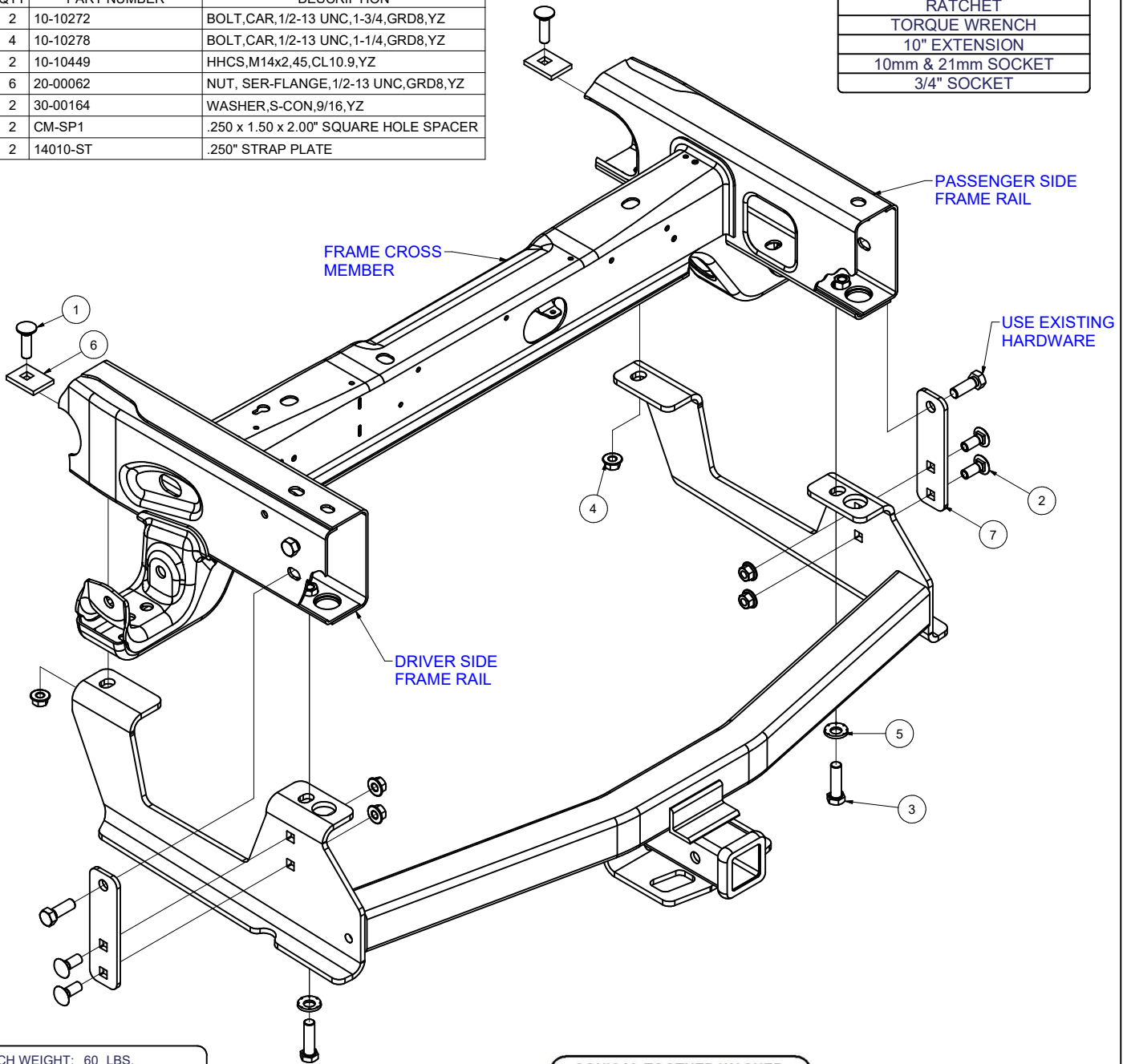

HITCH WEIGHT: 60 LBS.

INSTALL TIME

PROFESSIONAL: 20 MINUTES

NOVICE (DIY): 40 MINUTES

INSTALL NOTES:

- LOWER SPARE TIRE FOR EASE OF INSTALLATION
- NO DRILLING REQUIRED

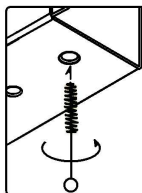

WELDNUT CLEANING

To remove debris from weldnuts in frame, spray lubricant or compressed air into hole. For heavy debris, use a small wire brush. (Be careful not to damage threads).

CONICAL TOOTHED WASHER ORIENTATION DIAGRAM

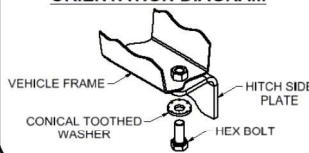

FRONT
↑
REAR

PERIODICALLY CHECK THIS RECEIVER HITCH TO ENSURE THAT ALL FASTENERS ARE TIGHT AND THAT ALL STRUCTURAL COMPONENTS ARE SOUND.



Scan for more information

CURT Manufacturing LLC., warrants this product to be free of defects in material and/or workmanship at the time of retail purchase by the original purchaser. If the product is found to be defective, CURT Manufacturing LLC., may repair or replace the product, at their option, when the product is returned, prepaid, with proof of purchase. Alteration to, misuse of, or improper installation of this product voids the warranty. CURT Manufacturing LLC.'s liability is limited to repair or replacement of products found to be defective, and specifically excludes liability for incidental or consequential loss or damage.

GROSS LOAD CAPACITY WHEN USED AS A WEIGHT CARRYING HITCH: 10,000 LBS. TRAILER WEIGHT & 1,000 LBS. TONGUE WEIGHT.
 GROSS LOAD CAPACITY WHEN USED AS A WEIGHT DISTRIBUTION HITCH: 12,000 LBS. TRAILER WEIGHT & 1,200 LBS. TONGUE WEIGHT

***** DO NOT EXCEED VEHICLE MANUFACTURER'S RECOMMENDED TOWING CAPACITY. *****

HAVING INSTALLATION QUESTIONS? CALL TECHNICAL SUPPORT AT 1-877-287-8634

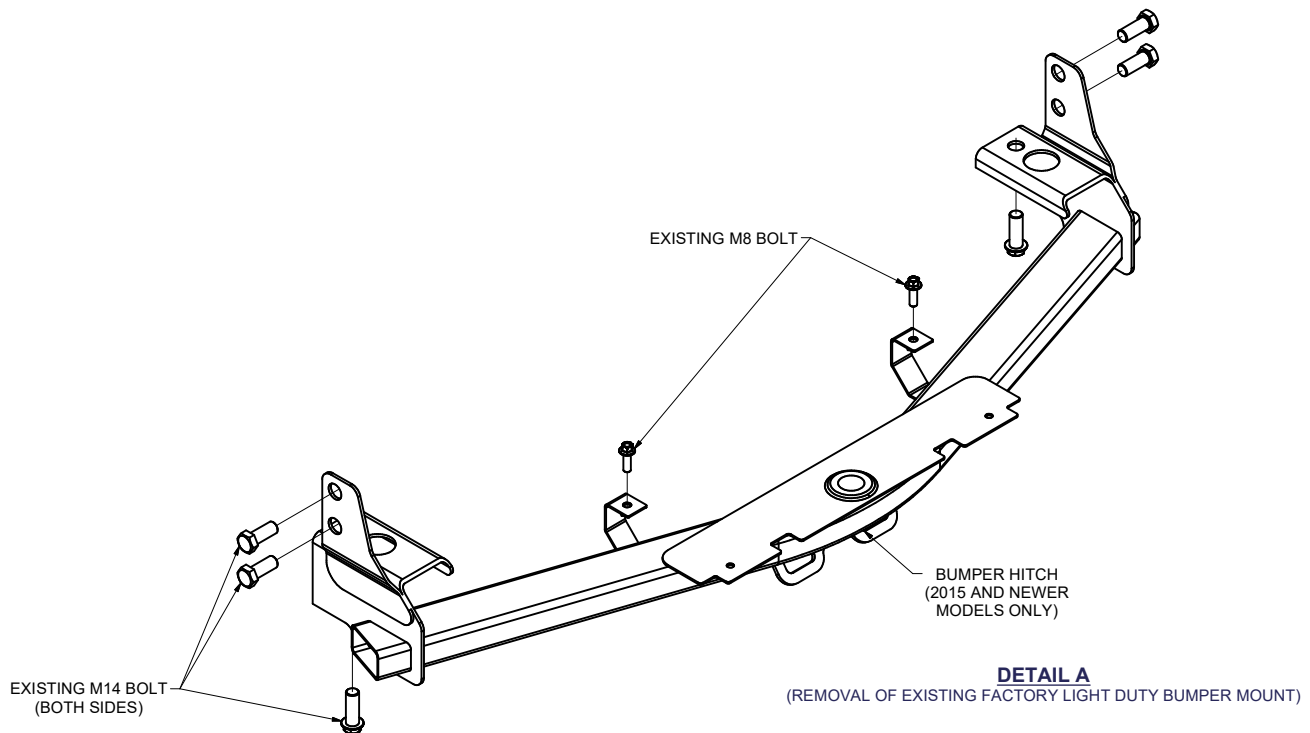

INSTALLATION STEPS

1. Temporarily lower spare tire from vehicle to ease installation.

NOTE: If removing factory hitch, retain the hardware for CURT hitch install.

2. On 2015 and newer non-hitch equipped vehicles you will need to remove a factory light duty bumper mount hitch prior to hitch installation.
 Remove this light duty bumper hitch as follows (See Detail A);
 - a. Remove (2) M8 bolts connecting the center hitch tabs to the bumper and return to owner.
 - b. Remove and retain (4) M14 bolts that secure the hitch to the side of the frame rails.
 - c. Remove (2) M14 bolts that secure the rear of the hitch to the weldnuts in the bottom of the frame rails.
 - d. Remove the hitch and return to owner.
3. Raise hitch into position, locating holes in hitch over weldnuts in vehicle frame. Weldnut cleaning may be necessary. (See WELDNUT CLEANING DIAGRAM)
4. Install M14 bolts and conical toothed washers through hitch into weldnuts in the bottom of vehicle frame.
5. Install 1/2" carriage bolts, spacers, and nuts as shown above.
6. Install (2) M14 bolts removed from Step 2b into the side of the frame rail. Also install (2) carriage bolts through each strap plate into the side plate.
7. Torque all M14 fasteners to 126 ft-lbs, and all 1/2" fasteners to 110 ft-lbs.
8. Raise spare tire back into position on vehicle if lowered.



Scan
for more
information

PERIODICALLY CHECK THIS RECEIVER HITCH TO ENSURE THAT ALL FASTENERS ARE TIGHT AND THAT ALL STRUCTURAL COMPONENTS ARE SOUND.

CURT Manufacturing LLC., warrants this product to be free of defects in material and/or workmanship at the time of retail purchase by the original purchaser. If the product is found to be defective, CURT Manufacturing LLC., may repair or replace the product, at their option, when the product is returned, prepaid, with proof of purchase. Alteration to, misuse of, or improper installation of this product voids the warranty. CURT Manufacturing LLC.'s liability is limited to repair or replacement of products found to be defective, and specifically excludes liability for incidental or consequential loss or damage.