

**14000****NISSAN NV 1500, 2500, & 3500 (ALL MODELS)**

7/27/2020

GROSS LOAD CAPACITY WHEN USED AS A WEIGHT CARRYING HITCH: 10,000 LBS. TRAILER WEIGHT & 1,000 LBS. TONGUE WEIGHT.  
 GROSS LOAD CAPACITY WHEN USED AS A WEIGHT DISTRIBUTION HITCH: 12,000 LBS. TRAILER WEIGHT & 1,200 LBS. TONGUE WEIGHT

**\*\*\*DO NOT EXCEED VEHICLE MANUFACTURER'S RECOMMENDED TOWING CAPACITY.\*\*\***

HAVING INSTALLATION QUESTIONS? CALL TECHNICAL SUPPORT AT 1-877-287-8634

Parts List			
ITEM	QTY	PART NUMBER	DESCRIPTION
1	8	10-10277	HHCS,M12x1.25,40CL10.9,YZ
2	8	30-00149	WASHER,S-CON,1/2,YZ
3	2	10-10300	BOLT,CAR,1/2-13 UNC,1,GRD8,YZ
4	2	20-00062	NUT, SER-FLANGE,1/2-13 UNC,GRD8,YZ

TOOLS REQUIRED	
TORQUE WRENCH	
RATCHET	
3/4" SOCKET	
19mm SOCKET	

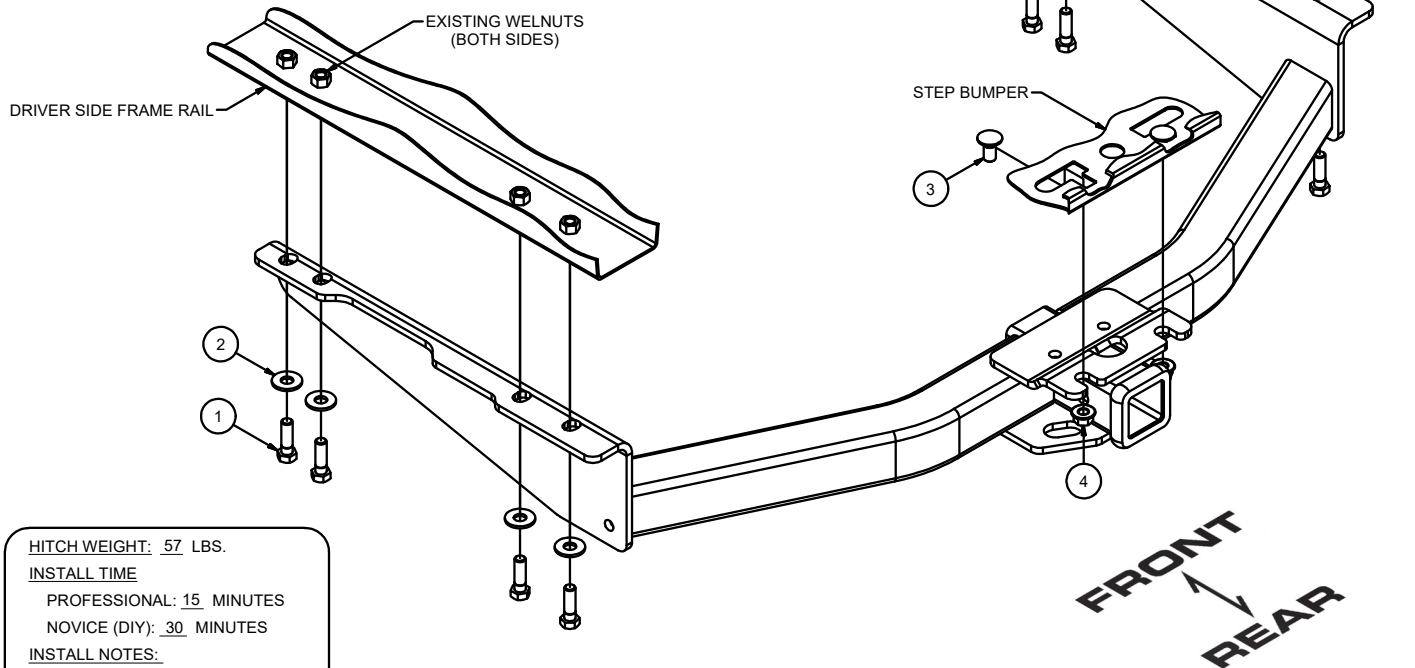
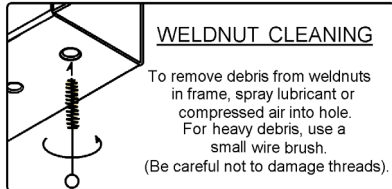

HITCH WEIGHT: 57 LBS.

INSTALL TIME

PROFESSIONAL: 15 MINUTES

NOVICE (DIY): 30 MINUTES

INSTALL NOTES:

- NO DRILLING REQUIRED

**INSTALLATION STEPS**

1. Insert 1/2-13 x 1" carriage bolts into the rear step bumper slots, as shown.
2. Raise hitch into position aligning holes in hitch with weldnuts in the frame rails and the carriage bolts installed in Step 1.
3. Secure hitch to weldnuts using M12-1.25 x 40 hex bolts and 1/2" conical toothed washers. See Weldnut Cleaning Detail
4. Secure the hitch to the step bumper using 1/2-13 hex flange nuts.
5. Torque all M12 hardware to 86 ft-lbs.  
Torque all 1/2" hardware to 110 ft-lbs.

**PERIODICALLY CHECK THIS RECEIVER HITCH TO ENSURE THAT ALL FASTENERS ARE TIGHT AND THAT ALL STRUCTURAL COMPONENTS ARE SOUND.**

Curt Manufacturing LLC., warrants this product to be free of defects in material and/or workmanship at the time of retail purchase by the original purchaser. If the product is found to be defective, Curt Manufacturing LLC., may repair or replace the product, at their option, when the product is returned, prepaid, with proof of purchase. Alteration to, misuse of, or improper installation of this product voids the warranty. Curt Manufacturing LLC.'s liability is limited to repair or replacement of products found to be defective, and specifically excludes liability for incidental or consequential loss or damage.