

13895**FORD / CHEVROLET / GMC MULTI-FIT**

11/12/2012

GROSS LOAD CAPACITY WHEN USED AS A WEIGHT CARRYING HITCH: **6,000 LBS. TRAILER WEIGHT & 600 LBS. TONGUE WEIGHT.**
 GROSS LOAD CAPACITY WHEN USED AS A WEIGHT DISTRIBUTION HITCH: **10,000 LBS. TRAILER WEIGHT & 1,000 LBS. TONGUE WEIGHT**

*****DO NOT EXCEED VEHICLE MANUFACTURER'S RECOMMENDED TOWING CAPACITY.*****

		Parts List	
ITEM	QTY	PART NUMBER	DESCRIPTION
1	1	1/2"	FISHWIRE TOOL
2	12	7/16-14 x 1	CARRIAGE BOLT
3	12	7/16-14	HEX FLANGE NUT
4	6	1/2-13 x 1 3/4	CARRIAGE BOLT
5	6	HFN 1213	HEX FLANGE NUT
6	2	M14-2 x 40mm LG.	HEX BOLT
7	2	1/2"	CONICAL TOOTHED WASHER
8	6	CM-SP6	.250 x 1.00 x 3.00" SQUARE HOLE SPACER
9	2	CM-13895-S	.250" STRAP

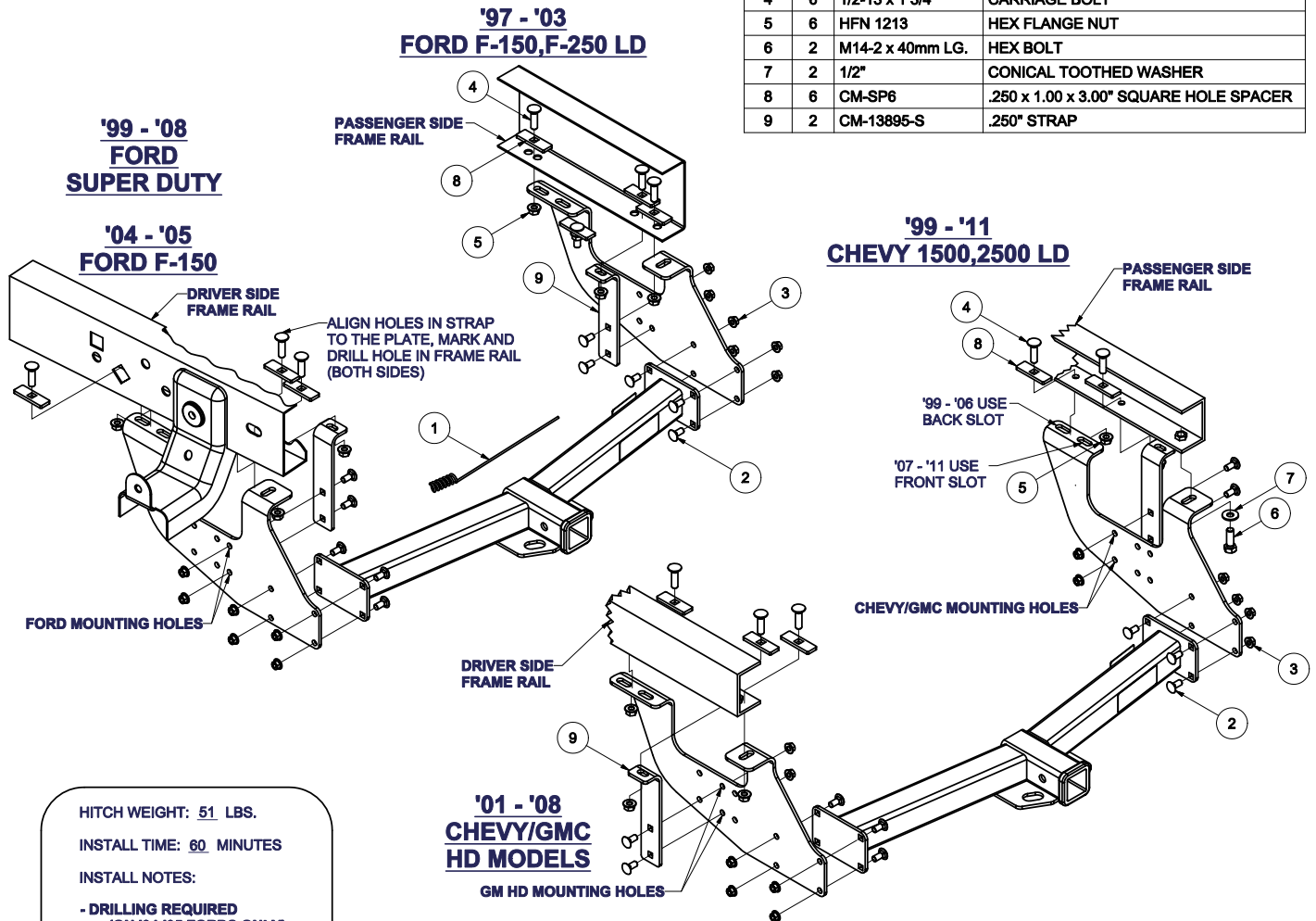
HITCH WEIGHT: 51 LBS.INSTALL TIME: 60 MINUTES

INSTALL NOTES:

- DRILLING REQUIRED
 (ON '04-'05 FORDS ONLY)

INSTALLATION STEPS

- 1) Place supplied fasteners into position on vehicle where possible without drilling, per application.
- 2) Mount side plates to frame rails as shown above (Ford in, Chevy/GMC out). Raise center section into position and loosely secure to side plates.
- 3) Drill remaining holes if necessary. ('03-'04 Ford trucks)
- 4) Install remaining fasteners.
- 5) Torque all 7/16" fasteners to 70 lb-ft, all 1/2" fasteners to 110 lb-ft, and all 14mm fasteners to 126 lb-ft.

PERIODICALLY CHECK THIS RECEIVER HITCH TO ENSURE THAT ALL FASTENERS ARE TIGHT AND THAT ALL STRUCTURAL COMPONENTS ARE SOUND.

Curt Manufacturing Inc., warrants this product to be free of defects in material and/or workmanship at the time of retail purchase by the original purchaser. If the product is found to be defective, Curt Manufacturing Inc., may repair or replace the product, at their option, when the product is returned, prepaid, with proof of purchase. Alteration to, misuse of, or improper installation of this product voids the warranty. Curt Manufacturing Inc.'s liability is limited to repair or replacement of products found to be defective, and specifically excludes liability for incidental or consequential loss or damage.

11/12/2012