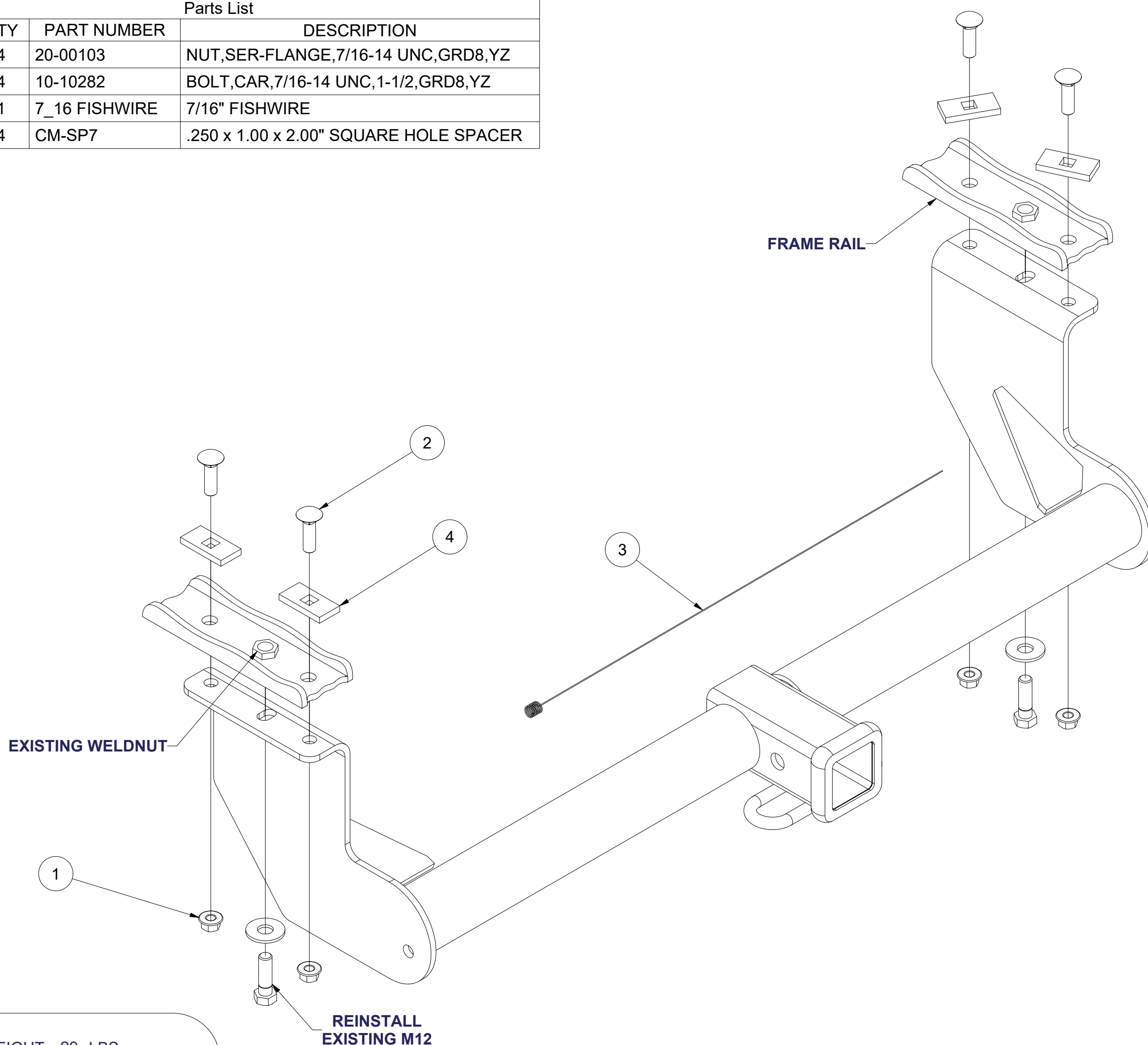

13556**99-01 ISUZU VEHICROSS**

2/1/2021

GROSS LOAD CAPACITY WHEN USED AS A WEIGHT CARRYING HITCH: 3,500 LBS. TRAILER WEIGHT & 300 LBS. TONGUE WEIGHT.
*****DO NOT EXCEED VEHICLE MANUFACTURER'S RECOMMENDED TOWING CAPACITY.*****

Parts List			
ITEM	QTY	PART NUMBER	DESCRIPTION
1	4	20-00103	NUT,SER-FLANGE,7/16-14 UNC,GRD8,YZ
2	4	10-10282	BOLT,CAR,7/16-14 UNC,1-1/2,GRD8,YZ
3	1	7_16 FISHWIRE	7/16" FISHWIRE
4	4	CM-SP7	.250 x 1.00 x 2.00" SQUARE HOLE SPACER

HITCH WEIGHT: 29 LBS.INSTALL TIME: 20 MINUTES

INSTALL NOTES:

DRILLING REQUIRED**INSTALLATION STEPS**

- 1) Under rear side of vehicle locate and remove tie down brackets on both left and right frame rails.
- 2) Lift hitch into position on bottom of frame rails and attach at center slotted holes in hitch side plates, re-using existing bolts from tie down brackets.
- 3) Use hitch as a template and drill remaining holes.
- 4) Using a fishwire, pull carriage bolts and spacers through frame rails and into holes. Install fasteners as shown.
- 5) Torque all 7/16" hardware to 70 lb.-ft. and all M12 bolts to 79 lb.-ft.

PERIODICALLY CHECK THIS RECEIVER HITCH TO ENSURE THAT ALL FASTENERS ARE TIGHT AND THAT ALL STRUCTURAL COMPONENTS ARE SOUND.

Curt Manufacturing Inc., warrants this product to be free of defects in material and/or workmanship at the time of retail purchase by the original purchaser. If the product is found to be defective, Curt Manufacturing Inc., may repair or replace the product, at their option, when the product is returned, prepaid, with proof of purchase. Alteration to, misuse of, or improper installation of this product voids the warranty. Curt Manufacturing Inc.'s liability is limited to repair or replacement of products found to be defective, and specifically excludes liability for incidental or consequential loss or damage.

2/1/2021