

13514**NISSAN XTERRA**

7/2/2020

GROSS LOAD CAPACITY WHEN USED AS A WEIGHT CARRYING HITCH: 4,000 LBS. TRAILER WEIGHT & 400 LBS. TONGUE WEIGHT.
 GROSS LOAD CAPACITY WHEN USED AS A WEIGHT DISTRIBUTION HITCH: 6,000 LBS. TRAILER WEIGHT & 600 LBS. TONGUE WEIGHT

*****DO NOT EXCEED VEHICLE MANUFACTURER'S RECOMMENDED TOWING CAPACITY.*****

HAVING INSTALLATION QUESTIONS? CALL TECHNICAL SUPPORT AT 1-877-287-8634

Parts List			
ITEM	QTY	PART NUMBER	DESCRIPTION
1	4	10-10269	HEX TAP BOLT
2	4	30-00194	WASHER, LOCK, 9/16, YZ
3	2	10-10275	HEX TAP BOLT
4	2	30-00149	WASHER, S-CON, 1/2, YZ

TOOLS REQUIRED
1/2" RATCHET
TORQUE WRENCH
6" EXTENSION
22mm SOCKET
19mm SOCKET
12mm SOCKET
12mm WRENCH

**RUBBER ISOLATOR
REMOVAL DIAGRAM**

This technique can be used if and Exhaust Hanger Removal Pliers is not available.

Using a 5/8" open end wrench, slide the wrench up to the rubber isolator, cradling the hanger rod as shown. Next place the flat edge of a pry bar between the wrench and the hanger stop or hanger rod. Then simply rotate the pry bar toward the wrench to remove the rubber isolator.

Note: Using a spray lubricant or soapy water on the hanger rod and the rubber isolator helps removal.

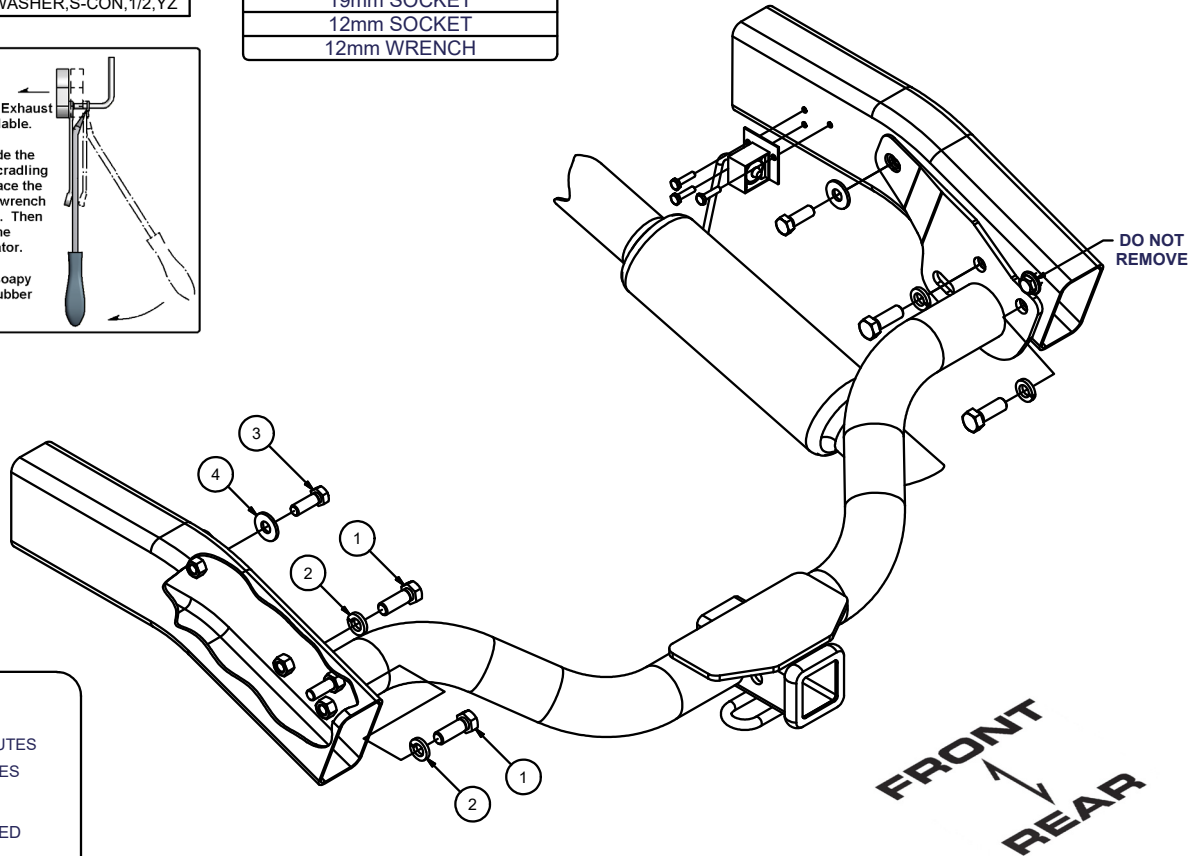
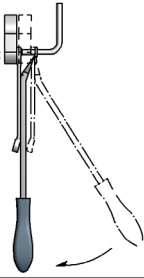

HITCH WEIGHT: 30 LBS.

INSTALL TIME

PROFESSIONAL: 30 MINUTES

NOVICE (DIY): 60 MINUTES

INSTALL NOTES:

- NO DRILLING REQUIRED
- LOWER SPARE
- LOWER EXHAUST

INSTALLATION STEPS

- 1) Lower spare tire for ease of installation. (Replace later)
- 2) Lower exhaust by removing (3) bolts from exhaust hanger bracket as shown. (Re-use later)
- 3) Remove the lower (2) bumper bracket bolts on both side of vehicle as shown. (Discard)
(NOTE: DO NOT REMOVE TOP BOLT)
- 4) Raise hitch into position over exhaust and secure with M12 hex bolts and conical washers, finger tighten.
- 5) Install remaining M14 hex bolts and lock washers through hitch and bumper bracket as shown.
- 6) Reinstall exhaust hanger bracket removed in step 2.
- 7) Torque all M12 fasteners to 86 lb-ft and all M14 fasteners to 136 lb-ft.
- 8) Reinstall spare tire lowered in step 1.

PERIODICALLY CHECK THIS RECEIVER HITCH TO ENSURE THAT ALL FASTENERS ARE TIGHT AND THAT ALL STRUCTURAL COMPONENTS ARE SOUND.

Curt Manufacturing Inc., warrants this product to be free of defects in material and/or workmanship at the time of retail purchase by the original purchaser. If the product is found to be defective, Curt Manufacturing Inc., may repair or replace the product, at their option, when the product is returned, prepaid, with proof of purchase. Alteration to, misuse of, or improper installation of this product voids the warranty. Curt Manufacturing Inc.'s liability is limited to repair or replacement of products found to be defective, and specifically excludes liability for incidental or consequential loss or damage.