

**13223****97-04 MITSUBISHI MONTERO SPORT****9/22/2020**

GROSS LOAD CAPACITY WHEN USED AS A WEIGHT CARRYING HITCH: 5,000 LBS. TRAILER WEIGHT & 500 LBS. TONGUE WEIGHT.  
 GROSS LOAD CAPACITY WHEN USED AS A WEIGHT DISTRIBUTION HITCH: 6,000 LBS. TRAILER WEIGHT & 600 LBS. TONGUE WEIGHT

**\*\*\* DO NOT EXCEED VEHICLE MANUFACTURER'S RECOMMENDED TOWING CAPACITY. \*\*\***

HAVING INSTALLATION QUESTIONS? CALL TECHNICAL SUPPORT AT 1-877-287-8634

| Parts List |     |             |  |
|------------|-----|-------------|--|
| ITEM       | QTY | PART NUMBER | DESCRIPTION                            |
| 1          | 2   | 30-00149    | WASHER, S-CON, 1/2, YZ                 |
| 2          | 4   | 30-00166    | WASHER, FLAT, 7/16, YZ                 |
| 3          | 4   | 20-00103    | NUT, SER-FLANGE, 7/16-14 UNC, GRD8, YZ |
| 4          | 2   | 10-10419    | HHCS, M12x1.25, 30, CL10.9, YZ         |
| 5          | 4   | 10-10536    | 7/16-14 x 5 HEX BOLT                   |

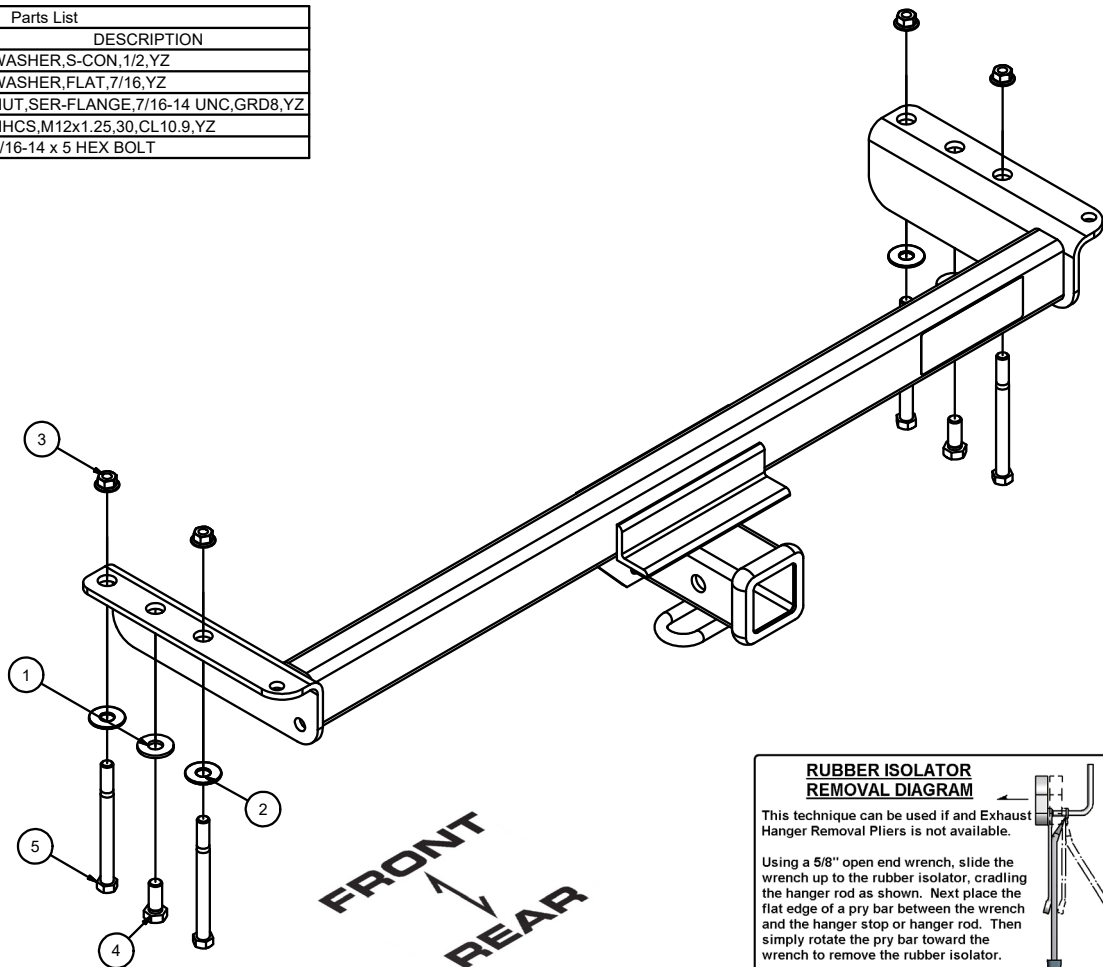

**RUBBER ISOLATOR  
REMOVAL DIAGRAM**

This technique can be used if and Exhaust Hanger Removal Pliers is not available.

Using a 5/8" open end wrench, slide the wrench up to the rubber isolator, cradling the hanger rod as shown. Next place the flat edge of a pry bar between the wrench and the hanger stop or hanger rod. Then simply rotate the pry bar toward the wrench to remove the rubber isolator.

Note: Using a spray lubricant or soapy water on the hanger rod and the rubber isolator helps removal.

HITCH WEIGHT: 27 LBS.

INSTALL TIME

PROFESSIONAL: 45 MINUTES

NOVICE (DIY): 90 MINUTES

INSTALL NOTES:

**NO DRILLING REQUIRED**

## INSTALLATION STEPS

- 1) REMOVE TOW HOOKS IF PRESENT. IF TOW HOOKS ARE NOT PRESENT REMOVE THE EXISTING HARDWARE FROM THE FRAME.
- 2) IT MAY BE NECESSARY TO LOWER OR REMOVE THE SPARE TIRE.
- 3) FOR EASE OF INSTALLATION YOU MAY CHOOSE TO LOWER THE EXHAUST.
- 4) RAISE THE HITCH INTO POSITION AND ATTACH IT WITH THE FASTENERS AS SHOWN. TORQUE THE M12 HARDWARE TO 86 FT/LBS AND THE 7/16 HARDWARE TO 70 FT/LBS.
- 5) RE-ATTACH THE EXHAUST AND RETURN THE SPARE TIRE TO ITS PROPER LOCATION.

**PERIODICALLY CHECK THIS RECEIVER HITCH TO ENSURE THAT ALL FASTENERS ARE TIGHT AND THAT ALL STRUCTURAL COMPONENTS ARE SOUND.**

Curt Manufacturing Inc., warrants this product to be free of defects in material and/or workmanship at the time of retail purchase by the original purchaser. If the product is found to be defective, Curt Manufacturing Inc., may repair or replace the product, at their option, when the product is returned, prepaid, with proof of purchase. Alteration to, misuse of, or improper installation of this product voids the warranty. Curt Manufacturing Inc.'s liability is limited to repair or replacement of products found to be defective, and specifically excludes liability for incidental or consequential loss or damage.