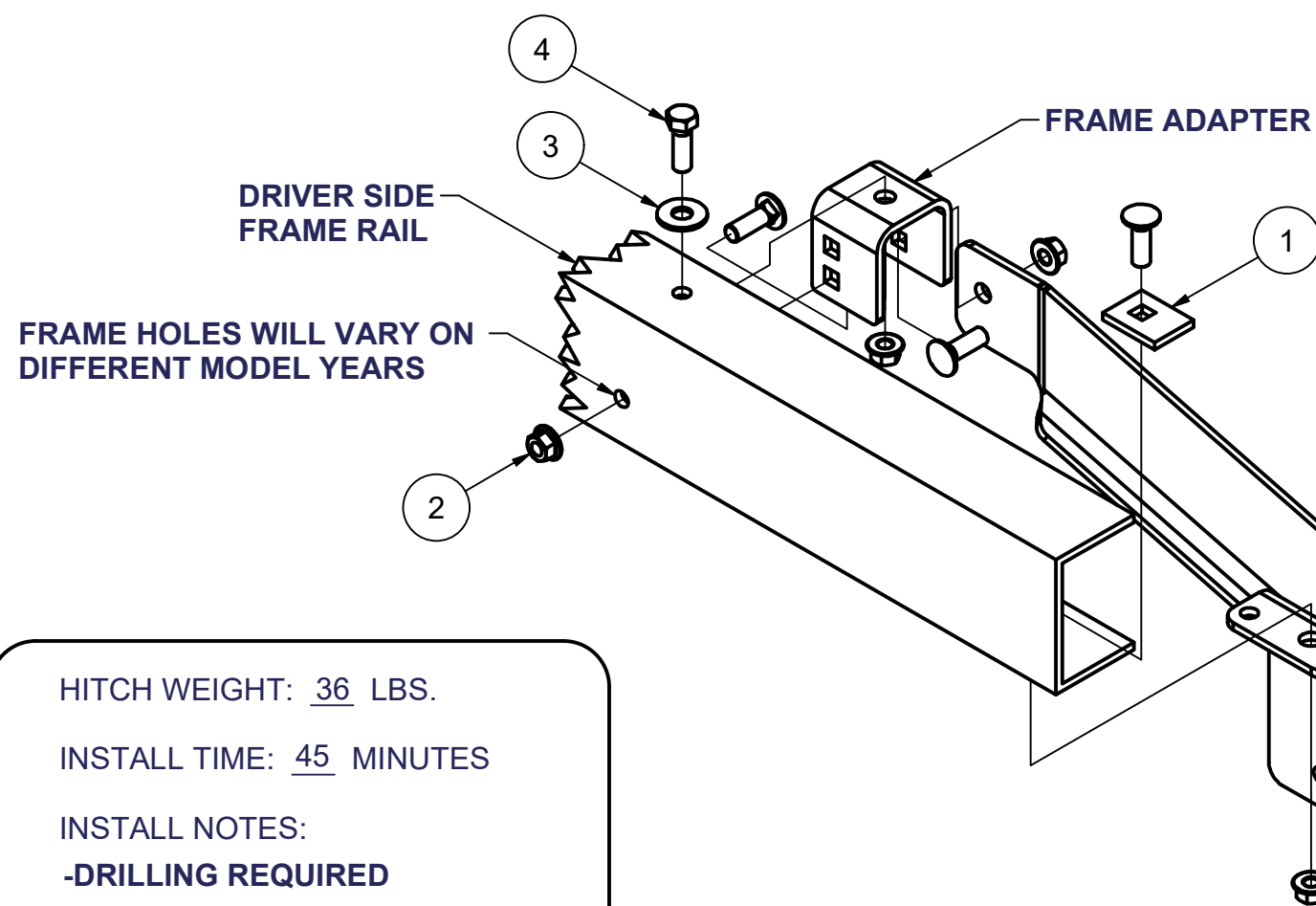
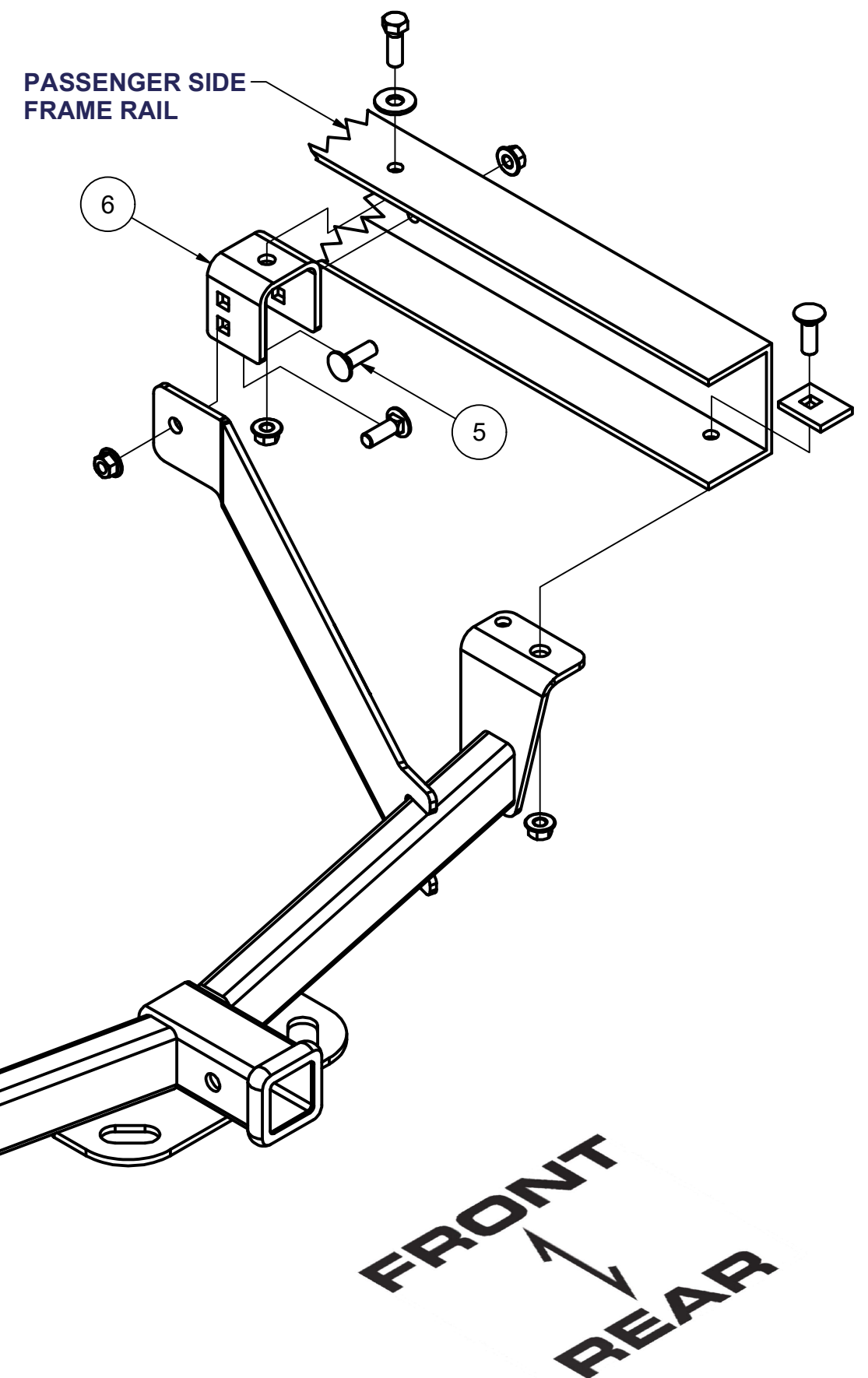

13106**1991-2001 FORD EXPLORER 4 DR, 1991-2003 FORD EXPLORER SPORT 2 DR,
1996-2001 MERCURY MOUNTAINEER****1/29/2021****GROSS LOAD CAPACITY WHEN USED AS A WEIGHT CARRYING HITCH: 5000 LBS. TRAILER WEIGHT & 500 LBS. TONGUE WEIGHT.
GROSS LOAD CAPACITY WHEN USED AS A WEIGHT DISTRIBUTION HITCH: 6000 LBS. TRAILER WEIGHT & 600 LBS. TONGUE WEIGHT*******DO NOT EXCEED VEHICLE MANUFACTURER'S RECOMMENDED TOWING CAPACITY.*****

Parts List			
ITEM	QTY	PART NUMBER	DESCRIPTION
1	2	CM-SP1	.250 x 1.50 x 2.00" SQUARE HOLE SPACER
2	8	20-00062	NUT, SER-FLANGE, 1/2-13 UNC, GRD8, YZ
3	2	30-00133	WASHER
4	2	10-10334	HHCS, 1/2-13 UNC, 1-1/2, GRD8, YZ
5	6	10-10287	BOLT, CAR, 1/2-13 UNC, 1-1/2, GRD8, YZ
6	2	CM-13106-FA	.250" FRAME ADAPTER

HITCH WEIGHT: 36 LBS.INSTALL TIME: 45 MINUTES

INSTALL NOTES:

-DRILLING REQUIRED

-MUST REMOVE
TOW HOOK FROM VEHICLE**INSTALLATION STEPS**

- 1) Attach adapter brackets to the existing holes which are located approximately 18" from the rear end of the frame. Remove spare tire to make installation easier.
- 2) Orient the adapter brackets as shown. Place the brackets in the vehicle frame and align with existing holes which were located in step 1. Install all bracket-frame fasteners as shown.
NOTE: Unless adapter brackets are properly positioned, hitch cannot be installed.
- 3) Check the spacing between the long hitch brackets. The brackets may need to be deflected to achieve proper measurement, 33 7/8".
- 4) Raise the hitch into position. Align the holes in the long hitch bracket with hole in the adapter bracket. Use the lower holes in the adapter bracket on passenger side and the upper holes on the driver side. Long brackets are placed on the inboard surface of the adapter bracket (nearest the spare tire).
- 94 and Prior Models**
- 5) Using the hole in the hitch bracket as a template, drill 1/2" hole through the frame rail. Install hitch-frame fasteners as shown.
- 95 and Later Models**
- 6) The hole in the hitch bracket should align with the existing frame holes.
- 7) Torque all fasteners to 110 lb.-ft.

**PERIODICALLY CHECK THIS RECEIVER HITCH TO ENSURE THAT ALL FASTENERS
ARE TIGHT AND THAT ALL STRUCTURAL COMPONENTS ARE SOUND.**

Curt Manufacturing Inc., warrants this product to be free of defects in material and/or workmanship at the time of retail purchase by the original purchaser. If the product is found to be defective, Curt Manufacturing Inc., may repair or replace the product, at their option, when the product is returned, prepaid, with proof of purchase. Alteration to, misuse of, or improper installation of this product voids the warranty. Curt Manufacturing Inc.'s liability is limited to repair or replacement of products found to be defective, and specifically excludes liability for incidental or consequential loss or damage.