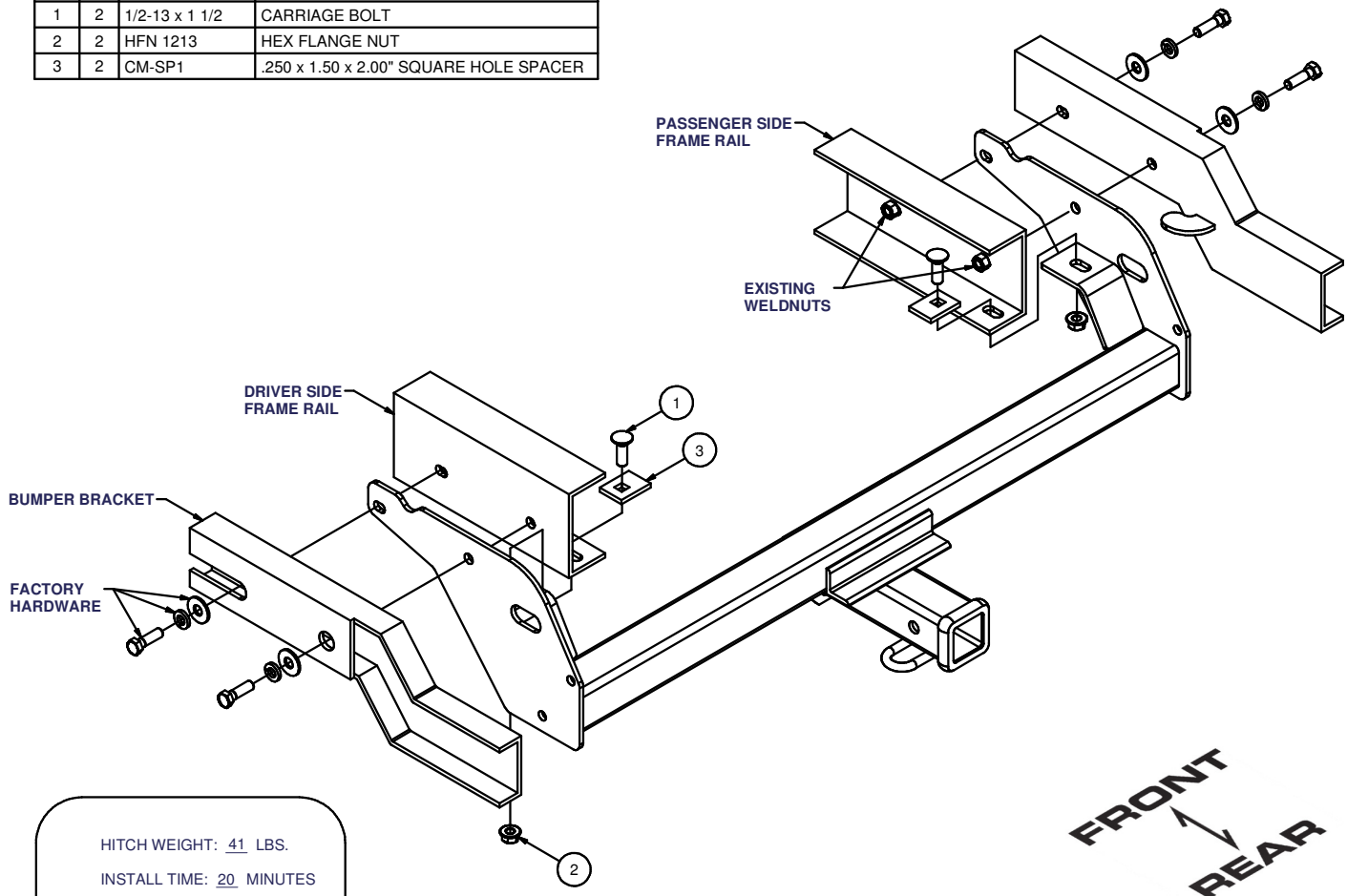

13013 / 78164 / RRH13013**95 - 04 TOYOTA TACOMA (ALL)**

7/11/2012

GROSS LOAD CAPACITY WHEN USED AS A WEIGHT CARRYING HITCH: 5,000 LBS. TRAILER WEIGHT & 500 LBS. TONGUE WEIGHT.
 GROSS LOAD CAPACITY WHEN USED AS A WEIGHT DISTRIBUTION HITCH: 6,000 LBS. TRAILER WEIGHT & 600 LBS. TONGUE WEIGHT
*****DO NOT EXCEED VEHICLE MANUFACTURER'S RECOMMENDED TOWING CAPACITY.*****

Parts List			
ITEM	QTY	PART NUMBER	DESCRIPTION
1	2	1/2-13 x 1 1/2	CARRIAGE BOLT
2	2	HFN 1213	HEX FLANGE NUT
3	2	CM-SP1	.250 x 1.50 x 2.00" SQUARE HOLE SPACER

HITCH WEIGHT: 41 LBS.INSTALL TIME: 20 MINUTES

INSTALL NOTES:

- NO DRILLING REQUIRED
- MUST REMOVE BUMPER

INSTALLATION STEPS

- 1) Disconnect the license plate wiring connectors from the bumper.
- 2) Remove the two bolts mounting the bumper to the bumper brackets on each side. Remove the bumper from the vehicle.
- 3) Remove bumper brackets from the frame rails and the two bolts on each side.
- 4) Position the receiver against the frame and install the 1/2" bolts.
- 5) Re-install the bumper brackets and make sure the tabs go through the slots on the side bracket.
- 6) Re-install the bumper and license plate wires using the factory hardware.
- 7) Torque M12 fasteners to 86 lb-ft.
1/2" fasteners to 110 lb-ft.

PERIODICALLY CHECK THIS RECEIVER HITCH TO ENSURE THAT ALL FASTENERS ARE TIGHT AND THAT ALL STRUCTURAL COMPONENTS ARE SOUND.

Curt Manufacturing Inc., warrants this product to be free of defects in material and/or workmanship at the time of retail purchase by the original purchaser. If the product is found to be defective, Curt Manufacturing Inc., may repair or replace the product, at their option, when the product is returned, prepaid, with proof of purchase. Alteration to, misuse of, or improper installation of this product voids the warranty. Curt Manufacturing Inc.'s liability is limited to repair or replacement of products found to be defective, and specifically excludes liability for incidental or consequential loss or damage.