

12333**PONTIAC G6 & GT**

9/10/2012

GROSS LOAD CAPACITY WHEN USED AS A WEIGHT CARRYING HITCH: 3500 LBS. TRAILER WEIGHT & 350 LBS. TONGUE WEIGHT.*****DO NOT EXCEED VEHICLE MANUFACTURER'S RECOMMENDED TOWING CAPACITY.*******WARNING: ALL NON-TRAILER LOADS APPLIED TO THIS PRODUCT MUST BE SUPPORTED BY AUXILIARY STABILIZING STRAPS.****** FAILURE TO PROPERLY SUPPORT NON-TRAILER LOADS WILL VOID PRODUCT WARRANTY******HAVING INSTALLATION QUESTIONS? CALL TECHNICAL SUPPORT AT 1-800-798-0813**

| Parts List | | | |
|------------|-----|-------------------------|--|
| ITEM | QTY | PART NUMBER | DESCRIPTION |
| 1 | 6 | 1/2-13 x 1 1/2 | CARRIAGE BOLT |
| 2 | 1 | 1/2" | FISHWIRE TOOL |
| 3 | 6 | CM-SP10 | .250 x 1.00 x 2.50" SQUARE HOLE SPACER |
| 4 | 6 | HFN 1213 | HEX FLANGE NUT |
| 5 | 1 | M6 - 1.00 X 25 HEX BOLT | HEX BOLT |

FISHWIRE TECHNIQUE

INSERT COILED END OF FISHWIRE TOOL THROUGH HITCH MOUNTING HOLE IN VEHICLE FRAME RAIL AND OUT THE ACCESS HOLE. PASS COILED END OF FISHWIRE THROUGH SPACER AND THREAD BOLT INTO COIL. KINK WIRE TO KEEP SPACER SEPARATE FROM BOLT AS SHOWN. PULL FISHWIRE, SPACER, AND BOLT THROUGH FRAME AND OUT MOUNTING HOLE. USE FISHWIRE TO GUIDE HITCH DURING MOUNTING AND PREVENT LOSS OF BOLT / SPACER INSIDE FRAME RAIL.

NOTE: SOME VEHICLES MAY FISHWIRE THROUGH END OF FRAME

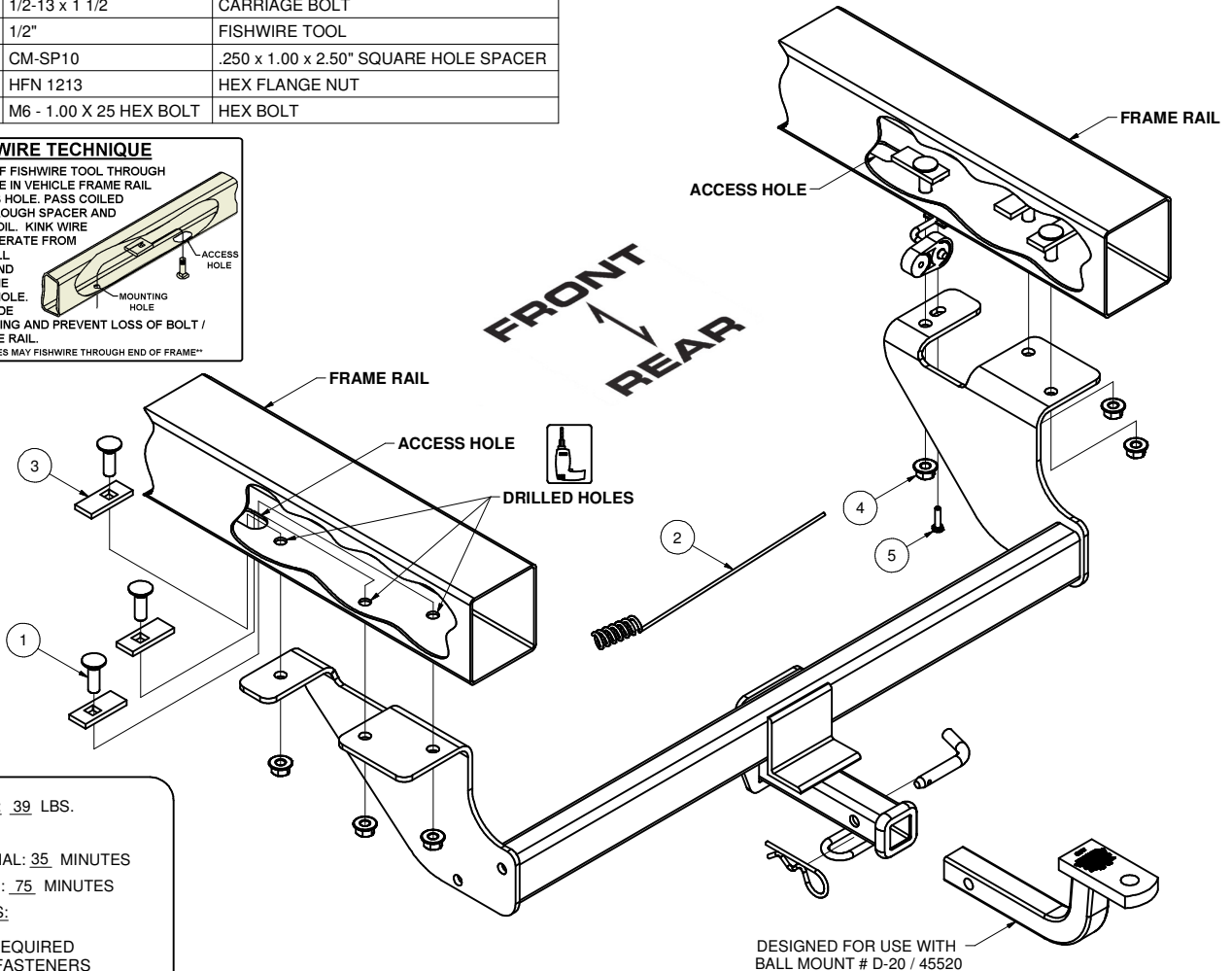

HITCH WEIGHT: .39 LBS.

INSTALL TIME

PROFESSIONAL: .35 MINUTES

NOVICE (DIY): .75 MINUTES

INSTALL NOTES:

- DRILLING REQUIRED
- FISHWIRE FASTENERS

INSTALLATION STEPS

- 1) Remove wire mounting strap from passengers side frame rail. (Reuse later)
- 2) Locate and mark the center of the vehicle.
- 3) Raise hitch into position, with hitch centered and square to vehicle mark and center punch (6) mounting holes. (Note: rear slot on passenger side will match up with existing strap mounting hole on vehicle.)
- 4) Drill (6) mounting holes using a 17/32" drill.
- 5) Fishwire 1/2" carriage bolts and spacers through existing access holes in frame and out drilled holes as shown. (See FISHWIRE TECHNIQUE) (Note: passenger side access hole is under strap.)
- 6) Raise hitch into position over carriage bolts and under wire mounting strap, secure with flange nuts as shown.
- 7) Reattach strap removed in step 1 using M6 bolt through slot in hitch.
- 8) Torque all 1/2" fasteners to 110 lb-ft and M6 bolt to 9 lb-ft.

PERIODICALLY CHECK THIS RECEIVER HITCH TO ENSURE THAT ALL FASTENERS ARE TIGHT AND THAT ALL STRUCTURAL COMPONENTS ARE SOUND.

Curt Manufacturing Inc., warrants this product to be free of defects in material and/or workmanship at the time of retail purchase by the original purchaser. If the product is found to be defective, Curt Manufacturing Inc., may repair or replace the product, at their option, when the product is returned, prepaid, with proof of purchase. Alteration to, misuse of, or improper installation of this product voids the warranty. Curt Manufacturing Inc.'s liability is limited to repair or replacement of products found to be defective, and specifically excludes liability for incidental or consequential loss or damage.

36333