

**12312****NISSAN PICK-UP, KING CAB ONLY**

4/20/2011

**GROSS LOAD CAPACITY WHEN USED AS A WEIGHT CARRYING HITCH: 3,500 LBS. TRAILER WEIGHT & 300 LBS. TONGUE WEIGHT.**

\*\*\*DO NOT EXCEED VEHICLE MANUFACTURER'S RECOMMENDED TOWING CAPACITY.\*\*\*

**WARNING: ALL NON-TRAILER LOADS APPLIED TO THIS PRODUCT MUST BE SUPPORTED BY 18050 STABILIZING STRAPS.**

\*\* FAILURE TO PROPERLY SUPPORT NON-TRAILER LOADS WILL VOID PRODUCT WARRANTY\*\*

**HAVING INSTALLATION QUESTIONS? CALL TECHNICAL SUPPORT AT 1-800-798-0813**

|      |     | Parts List          |                                    |
|------|-----|---------------------|------------------------------------|
| ITEM | QTY | PART NUMBER         | DESCRIPTION                        |
| 1    | 1   | CM-12312-PSBP       | .250" PASSENGER SIDE BACKING PLATE |
| 2    | 1   | CM-12312-DSBP       | .250" DRIVER SIDE BACKING PLATE    |
| 3    | 1   | CM-12312-EB         | 2.00 x .188" EXHAUST BRACKET       |
| 4    | 1   | 5/16-18 x 1 1/4 LG. | HEX BOLT                           |
| 5    | 1   | 5/16"               | WASHER                             |
| 6    | 1   | 5/16"               | LOCK WASHER                        |
| 7    | 1   | 5/16-18 HEX NUT     | 5/16-18 HEX NUT                    |
| 8    | 10  | 1/2-13 x 1 3/4      | HEX BOLT                           |
| 9    | 10  | FW12                | FW, 12, ZP                         |
| 10   | 10  | HFN 1213            | HEX FLANGE NUT                     |

**FRONT**  
↑  
**REAR**

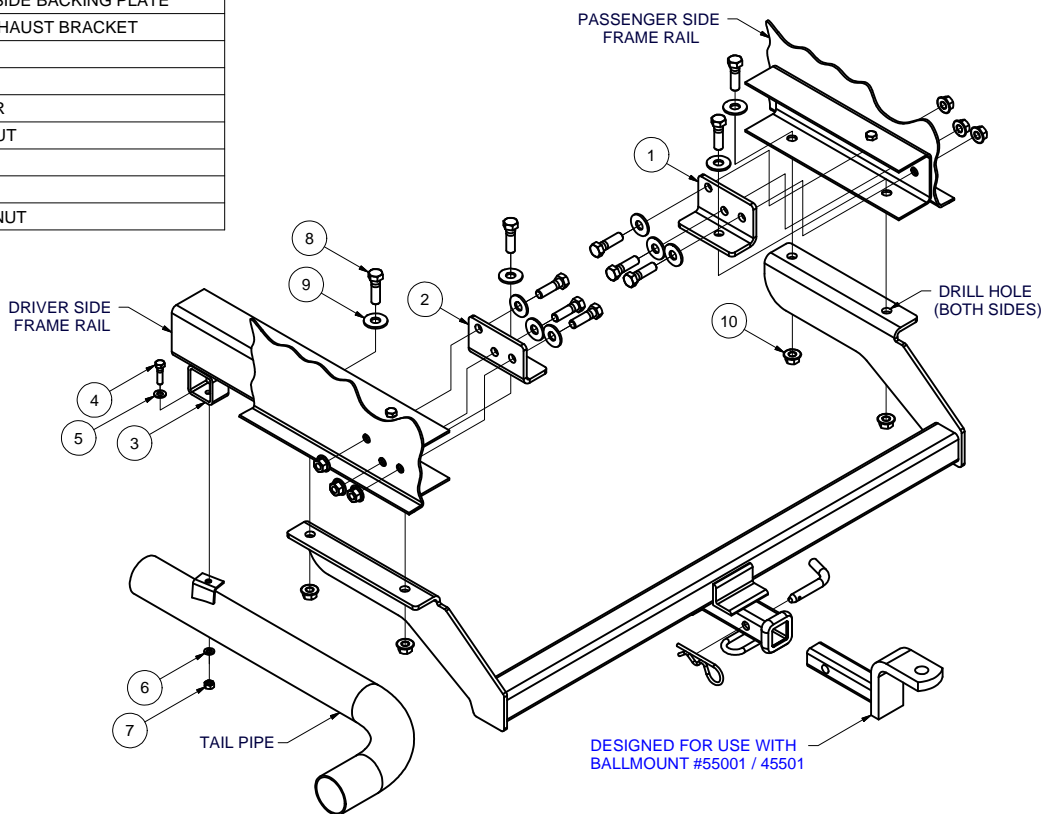

HITCH WEIGHT: 35 LBS.

**INSTALL TIME**

PROFESSIONAL: 45 MINUTES

NOVICE (DIY): 90 MINUTES

**INSTALL NOTES:**

- DRILLING REQUIRED
- LOWER EXHAUST

**INSTALLATION STEPS**

1. If the tailpipe extends under the left frame rail and interferes with the hitch fitting up to the frame as shown, lower the tailpipe by unbolting the rearmost exhaust hanger.
2. Install the CM-12312-DSBP and CM-12312-PSBP supplied with the hitch inside the driver and passenger side frame rails as shown. These brackets REPLACE existing brackets on pick-ups with rear bumpers. Install fasteners as shown.
3. Position the hitch onto the vehicle as shown using fasteners installed through angle brackets, frame bottom edge, and hitch. Mark and drill forward set of holes for 1/2" diameter bolts through frame bottom edge. It may be easier to mark the frame rail and temporarily remove the hitch to drill holes.
4. Finish installing the hitch, making sure all fasteners are tight and the bumper brackets are secure under the fasteners.
5. On vehicles where the exhaust had to be lowered, use the supplied CM-12312-EB exhaust hanger spacer to position the exhaust hanger down as shown.
6. Torque all 5/16" fasteners to 17 lb-ft, and all 1/2" fasteners to 75 lb-ft.

PERIODICALLY CHECK THIS RECEIVER HITCH TO ENSURE THAT ALL FASTENERS ARE TIGHT AND THAT ALL STRUCTURAL COMPONENTS ARE SOUND.

Curt Manufacturing Inc., warrants this product to be free of defects in material and/or workmanship at the time of retail purchase by the original purchaser. If the product is found to be defective, Curt Manufacturing Inc., may repair or replace the product, at their option, when the product is returned, prepaid, with proof of purchase. Alteration to, misuse of, or improper installation of this product voids the warranty. Curt Manufacturing Inc.'s liability is limited to repair or replacement of products found to be defective, and specifically excludes liability for incidental or consequential loss or damage.

367230