

12259**KIA AMANTI**

12/5/2012

GROSS LOAD CAPACITY WHEN USED AS A WEIGHT CARRYING HITCH: 3,500 LBS. TRAILER WEIGHT & 350 LBS. TONGUE WEIGHT.*****DO NOT EXCEED VEHICLE MANUFACTURER'S RECOMMENDED TOWING CAPACITY.*******WARNING: ALL NON-TRAILER LOADS APPLIED TO THIS PRODUCT MUST BE SUPPORTED BY AUXILIARY STABILIZING STRAPS.****** FAILURE TO PROPERLY SUPPORT NON-TRAILER LOADS WILL VOID PRODUCT WARRANTY******HAVING INSTALLATION QUESTIONS? CALL TECHNICAL SUPPORT AT 1-800-798-0813**

Parts List				
ITEM	QTY	PART NUMBER	DESCRIPTION	
1	2	M10 - 1.25 x 30	HEX BOLT	
2	2	7/16"	CONICAL TOOTHED WASHER	
3	1	1/2 - 13 x 2"	CARRIAGE BOLT	
4	1	HFN 1213	HEX FLANGE NUT	
5	1	CM-SP4	.250 x 1.50 x 3.00" SQUARE HOLE SPACER	

**RUBBER ISOLATOR
REMOVAL DIAGRAM**

This technique can be used if an Exhaust Hanger Removal Pliers is not available.

Using a 5/8" open end wrench, slide the wrench up to the rubber isolator, cradling the hanger rod as shown. Next place the flat edge of a pry bar between the wrench and the hanger stop or hanger rod. Then simply rotate the pry bar toward the wrench to remove the rubber isolator.

Note: Using a spray lubricant or soapy water on the hanger rod and the rubber isolator helps removal.

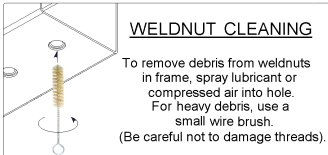
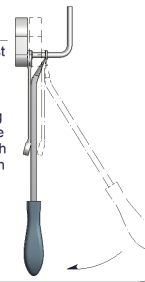

TOOLS REQUIRED	
PHILLIPS SCREW DRIVER	
3/8" DRIVE RATCHET	
17mm - 3/8" DRIVE SOCKET	
12mm - 3/8" DRIVE SOCKET	
10mm - 3/8" DRIVE SOCKET	
3/4" - 3/8" DRIVE SOCKET	
10" - 3/8" DRIVE EXTENSION	
3/8" DRIVE UNIVERSAL KNUCKLE	
3/8" DRIVE TORQUE WRENCH	

HITCH WEIGHT: 29 LBS.**INSTALL TIME**

PROFESSIONAL: 35 MINUTES

NOVICE (DIY): 75 MINUTES

INSTALL NOTES:

- NO DRILLING REQUIRED
- REMOVE PLASTIC FASCIA
- TEMPORARILY LOWER EXHAUST

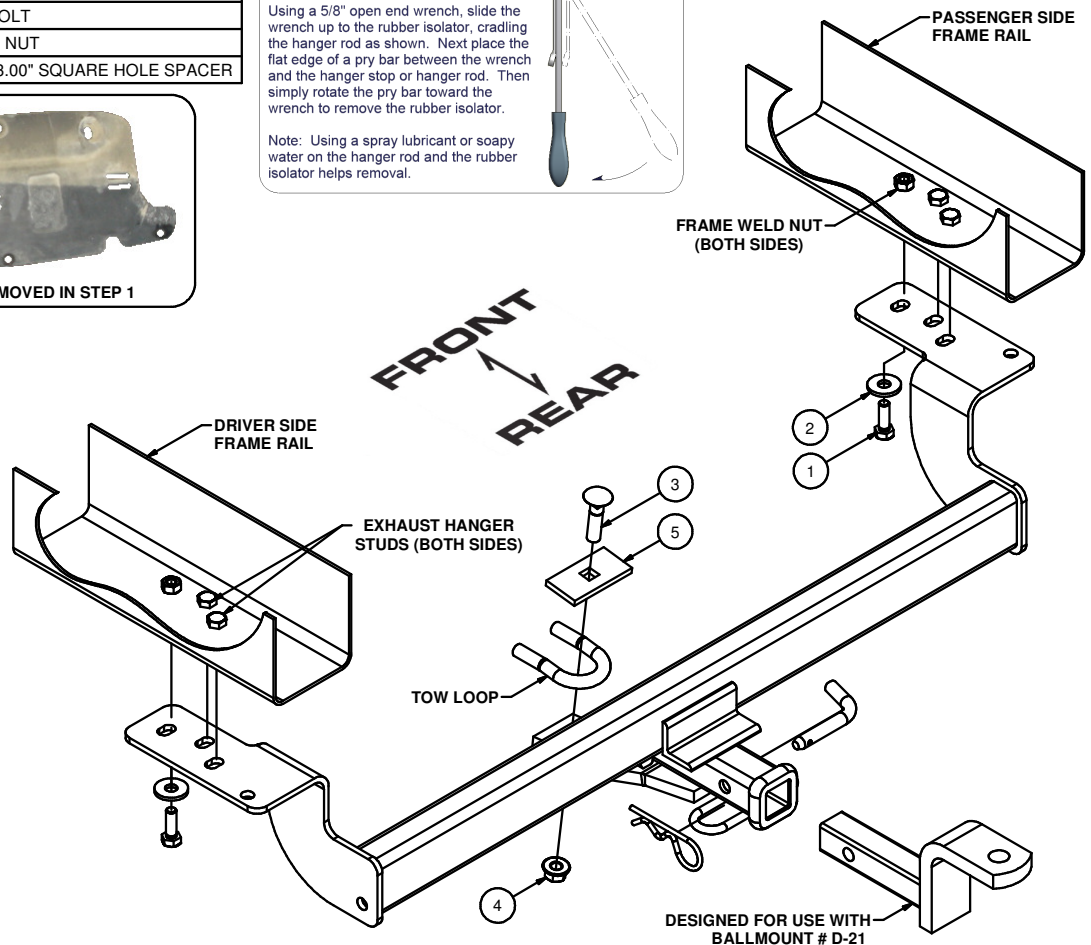
**INSTALLATION STEPS**

- 1) Remove (4) plastic Phillips head screws, (4) 10mm nuts, and plastic under body panel. (Return to customer) The under body panel is not used after hitch is installed.
- 2) Lower exhaust by removing (2) rear most hangers (Remove (2) nuts from each hanger on both sides of vehicle). To ease installation remove (2) rear rubber isolators just forward of the mufflers.
- 3) Place the 1/2" carriage bolt and spacer through the vehicle tow loop as shown. Raise hitch into position and secure with supplied 1/2" flange nut, finger tight.
- 4) Raise side plates to vehicle frame rail over existing exhaust hanger studs and secure with 10mm hex bolt and conical toothed washers into frame weld nuts.
- 5) Re-install exhaust and exhaust hangers removed in step 2.
(NOTE: Hitch side plates will be sandwiched between vehicle frame and exhaust hangers.)
- 6) Torque all 10mm fasteners to 48 lb-ft and all 1/2" fasteners to 110 lb-ft.

PERIODICALLY CHECK THIS RECEIVER HITCH TO ENSURE THAT ALL FASTENERS ARE TIGHT AND THAT ALL STRUCTURAL COMPONENTS ARE SOUND.

Curt Manufacturing Inc., warrants this product to be free of defects in material and/or workmanship at the time of retail purchase by the original purchaser. If the product is found to be defective, Curt Manufacturing Inc., may repair or replace the product, at their option, when the product is returned, prepaid, with proof of purchase. Alteration to, misuse of, or improper installation of this product voids the warranty. Curt Manufacturing Inc.'s liability is limited to repair or replacement of products found to be defective, and specifically excludes liability for incidental or consequential loss or damage.