

12244

05-CURRENT CHEVROLET UPLANDER, 05-07 SATURN RELAY, 05-07 PONTIAC TERAZZA,
 97-07 CHEVROLET VENTURE, 97-05 OLDSMOBILE SILHOUETTE TRANSPORT,
 05-07 PONTIAC MONTANA SV6 & 97-05 TRANS SPORT, 08-CURRENT PONTIAC MONTANA SV6 (CANADA ONLY)

7/18/2012

GROSS LOAD CAPACITY WHEN USED AS A WEIGHT CARRYING HITCH: 3,500 LBS. TRAILER WEIGHT & 350 LBS. TONGUE WEIGHT.

*****DO NOT EXCEED VEHICLE MANUFACTURER'S RECOMMENDED TOWING CAPACITY.*****

WARNING: ALL NON-TRAILER LOADS APPLIED TO THIS PRODUCT MUST BE SUPPORTED BY AUXILIARY STABILIZING STRAPS.

**** FAILURE TO PROPERLY SUPPORT NON-TRAILER LOADS WILL VOID PRODUCT WARRANTY****

HAVING INSTALLATION QUESTIONS? CALL TECHNICAL SUPPORT AT 1-800-798-0813

Parts List				
ITEM	QTY	PART NUMBER	DESCRIPTION	
1	2	1/2-13	HANDLE NUT	
2	2	1/2 - 13 x 1 1/2	HEX BOLT	
3	2	1/2"	CONICAL TOOTHED WASHER	
4	1	HFN 1213	HEX FLANGE NUT	
5	4	M10 - 1.5 x 45mm	HEX BOLT	
6	4	3/8"	CONICAL TOOTHED WASHER	
7	1	1/2 - 13 x 2"	CARRIAGE BOLT	
8	1	CM-SP1	.250 x 1.50 x 2.00" SQUARE HOLE SPACER	
9	1	CM-SP31	.250 x 1.75 x 2.00" U-SHAPE SPACER	
10	4	CM-SP42	.250 x 2.00 x 2.00" ROUND HOLE SPACER	
11	2	CM-SP32	.188 x 1.50 x 2.00" ROUND HOLE SPACER	
12	1	1 2 FISHWIRE	1/2" FISHWIRE	

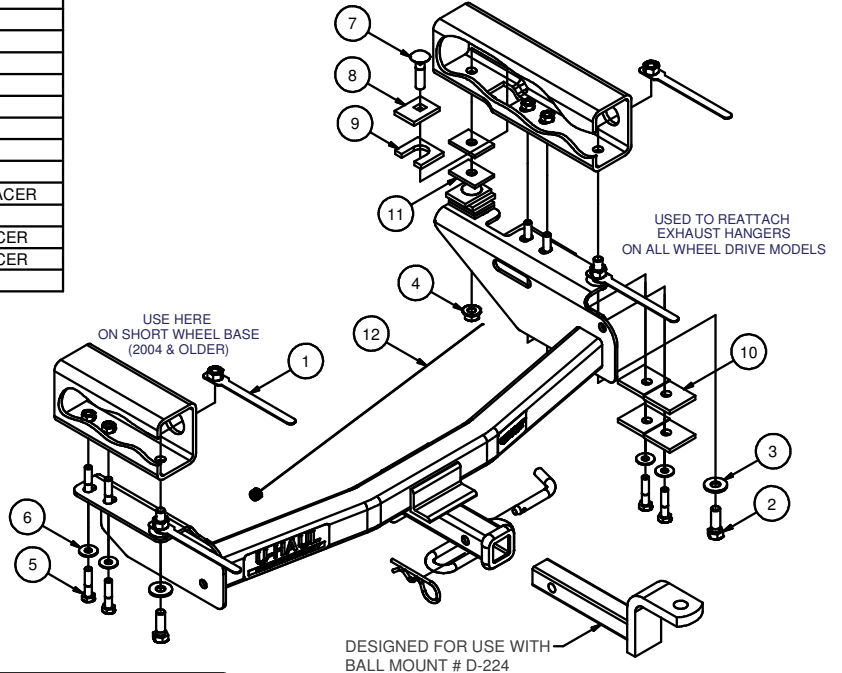

RUBBER ISOLATOR REMOVAL DIAGRAM

This technique can be used if and Exhaust Hanger Removal Pliers is not available.

Using a 5/8" open end wrench, slide the wrench up to the rubber isolator, cradling the hanger rod as shown. Next place the flat edge of a pry bar between the wrench and the hanger stop or hanger rod. Then simply rotate the pry bar toward the wrench to remove the rubber isolator.

Note: Using a spray lubricant or soapy water on the hanger rod and the rubber isolator helps removal.

FISHWIRE TECHNIQUE

INSERT COILED END OF FISHWIRE TOOL THROUGH HITCH MOUNTING HOLE IN VEHICLE FRAME RAIL AND OUT THE ACCESS HOLE. PASS COILED END OF FISHWIRE THROUGH SPACER AND THREAD BOLT INTO COIL. KINK WIRE TO KEEP SPACER SEPERATE FROM BOLT AS SHOWN. PULL FISHWIRE, SPACER, AND BOLT THROUGH FRAME AND OUT MOUNTING HOLE. USE FISHWIRE TO GUIDE HITCH DURING MOUNTING AND PREVENT LOSS OF BOLT / SPACER INSIDE FRAME RAIL.

NOTE: SOME VEHICLES MAY FISHWIRE THROUGH END OF FRAME

HITCH WEIGHT: 26 LBS.

INSTALL TIME

PROFESSIONAL: 45 MINUTES

NOVICE (DIY): 90 MINUTES

INSTALL NOTES:

DRILLING REQUIRED

INSTALLATION STEPS

- 1) Lower vehicle exhaust by removing the exhaust hanger on the passenger side.
- 2) If present, lower load leveling compressor on drivers side, (1) M10 bolt & (2) M6 nuts. **(Note: If necessary, trim vertical tab on compressor bracket to clear adjacent M10 bolt.)**
- 3) Raise hitch into position. Install M10-1.5 x 45mm bolts into existing weldnuts, both sides.
- 4) Use rearmost hole in hitch side plate as a template, drill 1/2" holes in vehicle frame rails. On *long wheel base* (LWB) models: It will be necessary to drill a 1/2" hole through forwardmost hole on the passenger side plate. On *short wheel base* (SWB) models: Forwardmost hole in the passenger side plate will line up with existing slot in vehicle frame rail.
- 5) On passenger side, Fishwire carriage bolt and blocks through existing slot in frame rail down into forwardmost hole as shown. Secure using blocks, lock washer and nuts as follows. *Short wheel base models:* Place (2) spacer blocks between frame rail and hitch. *Long wheel base models:* Place (2) spacer blocks between hitch and flange nut.(not shown). There may be some unused spacers after installation is complete.
- 6) Install handle nut through square hole in side of vehicle frame rail and install hex bolt and conical washer through rearmost hole as shown. **(Note: Drilled hole from step 4.)**
- 7) Remove M10 fasteners to reattach exhaust hanger and load leveling compressor, and reinstall fasteners. **(Note: On ALL WHEEL DRIVE (AWD) models, it will be necessary to pass exhaust hanger through 3" long slot in side plate, and use (2) 1/4" spacer blocks when reattaching exhaust hanger bracket.)**
- 8) Torque all 1/2" hardware to 110 lb-ft. Torque all M10 fasteners to 45 lb-ft. Torque all M6 fasteners to 9 lb-ft.

PERIODICALLY CHECK THIS RECEIVER HITCH TO ENSURE THAT ALL FASTENERS ARE TIGHT AND THAT ALL STRUCTURAL COMPONENTS ARE SOUND.

Curt Manufacturing Inc., warrants this product to be free of defects in material and/or workmanship at the time of retail purchase by the original purchaser. If the product is found to be defective, Curt Manufacturing Inc., may repair or replace the product, at their option, when the product is returned, prepaid, with proof of purchase. Alteration to, misuse of, or improper installation of this product voids the warranty. Curt Manufacturing Inc.'s liability is limited to repair or replacement of products found to be defective, and specifically excludes liability for incidental or consequential loss or damage.