

12190 CHRYSLER SEBRING TOURING CONVERTIBLE 2.7L V6 SINGLE EXHAUST

10/15/2020

GROSS LOAD CAPACITY WHEN USED AS A WEIGHT CARRYING HITCH: 3500 LBS. TRAILER WEIGHT & 350 LBS. TONGUE WEIGHT.
*****DO NOT EXCEED VEHICLE MANUFACTURER'S RECOMMENDED TOWING CAPACITY.*****

Parts List			
ITEM	QTY	PART NUMBER	DESCRIPTION
1	4	10-10407	HHCS, 1/2-13 UNC, 4, GRD8, YZ
2	1	CM-SP6	.250 x 1.00 x 3.00" SQUARE HOLE SPACER
3	1	10-10287	BOLT, CAR, 1/2-13 UNC, 1-1/2, GRD8, YZ
4	5	20-00062	NUT, SER-FLANGE, 1/2-13 UNC, GRD8, YZ
5	7	30-00133	WASHER, FLAT, 1/2, YZ
6	1	1_2 x 30 FISHWIRE	1/2" x 30" FISHWIRE

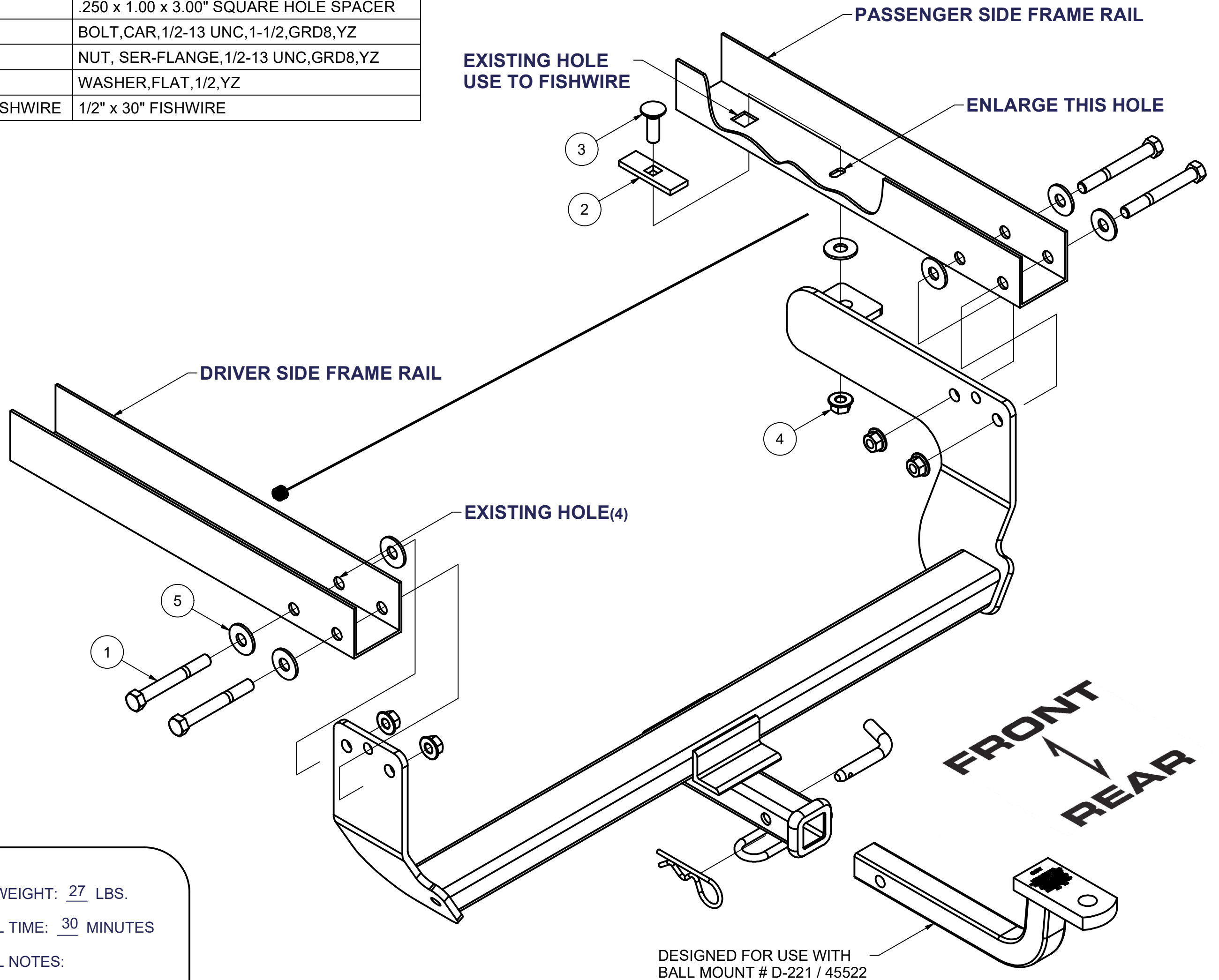

HITCH WEIGHT: 27 LBS.

INSTALL TIME: 30 MINUTES

INSTALL NOTES:

-HOLE ENLARGEMENT REQUIRED

INSTALLATION STEPS

- 1) Raise hitch into position between frame rails as shown. Push exhaust to side or lower if needed.
- 2) Install the four 4" hex bolts with washers from the outside of frames as shown (use washers on forward most holes as shown). Fasten with nuts finger tight to the sideplates.
- 3) With hitch in position, enlarge hole in frame at the flange of the passenger side plate with a 17/32" drill bit to fit a 1/2" bolt.
- 4) Fishwire 1 1/2" carriage bolt with square hole spacer through existing square hole in frame to the enlarged hole and fasten to side plate with nut. Finger tight only.
- 5) With all fasteners in place, torque all 1/2" hardware to 110 ft.-lb.

PERIODICALLY CHECK THIS RECEIVER HITCH TO ENSURE THAT ALL FASTENERS ARE TIGHT AND THAT ALL STRUCTURAL COMPONENTS ARE SOUND.

Curt Manufacturing Inc., warrants this product to be free of defects in material and/or workmanship at the time of retail purchase by the original purchaser. If the product is found to be defective, Curt Manufacturing Inc., may repair or replace the product, at their option, when the product is returned, prepaid, with proof of purchase. Alteration to, misuse of, or improper installation of this product voids the warranty. Curt Manufacturing Inc.'s liability is limited to repair or replacement of products found to be defective, and specifically excludes liability for incidental or consequential loss or damage.