

12128

92-99 PONTIAC BONNEVILLE SSE, SSEI

12/5/2012

GROSS LOAD CAPACITY WHEN USED AS A WEIGHT CARRYING HITCH: 3,500 LBS. TRAILER WEIGHT & 350 LBS. TONGUE WEIGHT.

*****DO NOT EXCEED VEHICLE MANUFACTURER'S RECOMMENDED TOWING CAPACITY.*******WARNING: ALL NON-TRAILER LOADS APPLIED TO THIS PRODUCT MUST BE SUPPORTED BY AUXILIARY STABILIZING STRAPS.****** FAILURE TO PROPERLY SUPPORT NON-TRAILER LOADS WILL VOID PRODUCT WARRANTY****

HAVING INSTALLATION QUESTIONS? CALL TECHNICAL SUPPORT AT 1-877-287-8634

Parts List			
ITEM	QTY	PART NUMBER	DESCRIPTION
1	10	5/16"	WASHER
2	2	CM-3801-UBS	3/8-16 x 1.94 x 2.50 SQ U-BOLT
3	4	3/8"	CONICAL TOOTHED WASHER
4	4	5/16-18	HEX FLANGE NUT
5	6	5/16-18 x 1 1/2	HEX BOLT
6	4	3/8 - 16	HEX NUT

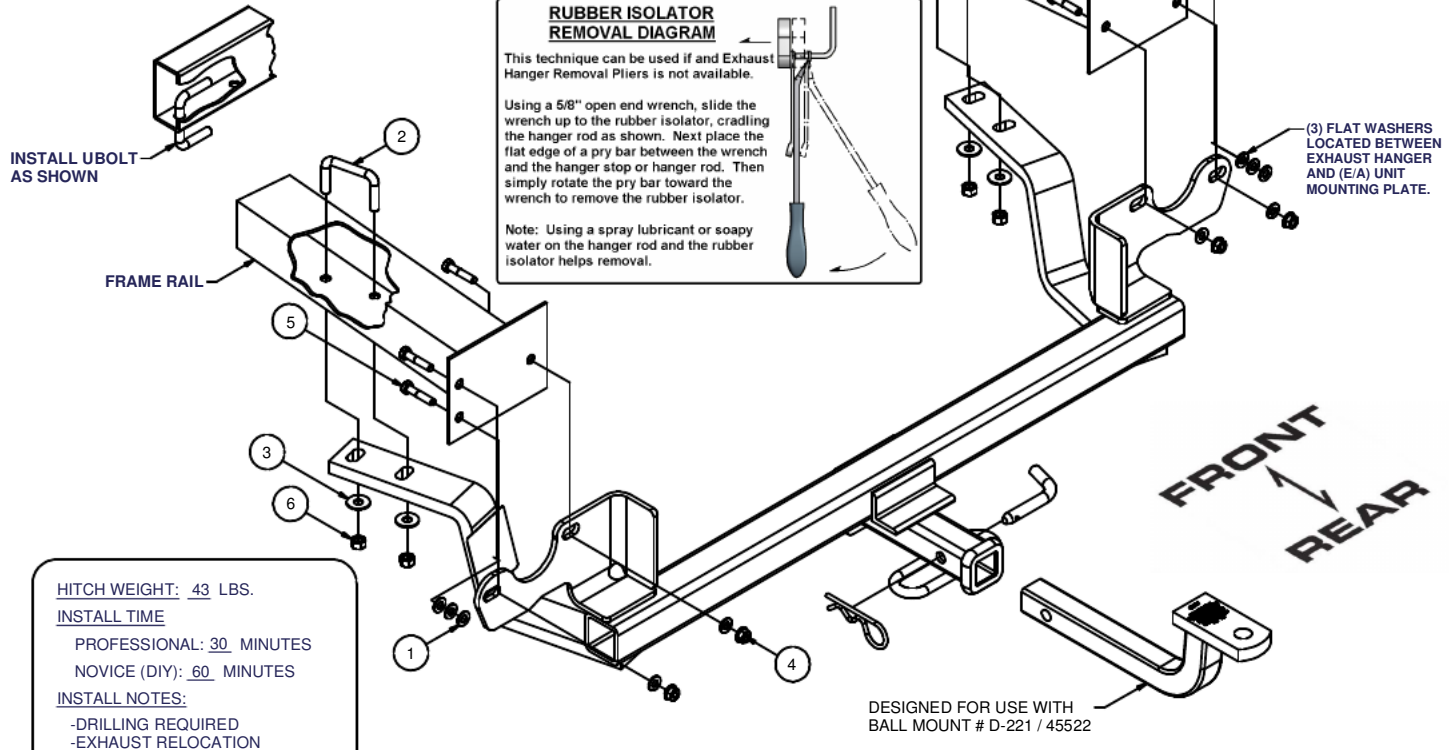

HITCH WEIGHT: 43 LBS.

INSTALL TIME

PROFESSIONAL: 30 MINUTES

NOVICE (DIY): 60 MINUTES

INSTALL NOTES:

- DRILLING REQUIRED
- EXHAUST RELOCATION

INSTALLATION STEPS

- 1) Remove all three energy absorber (E/A) unit mounting bolts from each side of frame.
- 2) Support muffler assembly with a wire or jack to prevent excess travel which could be damaging to exhaust system.
- 3) Position the hitch on the vehicle as shown and loosely install two M8 bolts provided (one each side). Use the hitch side arms as a template to mark holes in the frame. Lower the hitch and drill four 1/2" holes in the marked locations. **(Note: The side arms must sit flat against the vehicle frame. Chisel or drill out rivets holding heat shield under side arms as required. Also, bend heat shield as needed.)**
- 4) Remove the hitch to install the 3/8 U-bolts into the frame as shown.
- 5) Reposition the hitch on the vehicle and install fasteners as shown. **(Note: Be careful not to push U-bolts into frame.)**
- 6) Use three 5/16 flat washers provided to shim space between exhaust bracket and the upper outboard attachment for E/A unit. Use fasteners provided to attach exhaust hanger bracket. Deformation of sheet metal flanges on E/A mounting surfaces is permissible when fasteners are tightened. Optional: On late models with dual exhaust, reposition the muffler hanger bracket forward of the E/A unit. **(Note: Remove rubber hanger from bracket to allow access for installing M8 bolts. Using liquid hand soap helps hanger removal.)**
- 7) Torque M8 fasteners to 23 lb.-ft. Torque 3/8" fasteners to 45 lb.-ft.

PERIODICALLY CHECK THIS RECEIVER HITCH TO ENSURE THAT ALL FASTENERS ARE TIGHT AND THAT ALL STRUCTURAL COMPONENTS ARE SOUND.

Curt Manufacturing Inc., warrants this product to be free of defects in material and/or workmanship at the time of retail purchase by the original purchaser. If the product is found to be defective, Curt Manufacturing Inc., may repair or replace the product, at their option, when the product is returned, prepaid, with proof of purchase. Alteration to, misuse of, or improper installation of this product voids the warranty. Curt Manufacturing Inc.'s liability is limited to repair or replacement of products found to be defective, and specifically excludes liability for incidental or consequential loss or damage.