

# 12127

96-99 OLDSMOBILE DELTA 88 & EIGHTY EIGHT (INCLUDING LSS)  
96-99 PONTIAC BONNEVILLE (NOT SSE, SSEI)

10/23/2020

GROSS LOAD CAPACITY WHEN USED AS A WEIGHT CARRYING HITCH: 3,500 LBS. TRAILER WEIGHT & 350 LBS. TONGUE WEIGHT.

**\*\*\*DO NOT EXCEED VEHICLE MANUFACTURER'S RECOMMENDED TOWING CAPACITY.\*\*\***

WARNING: ALL NON-TRAILER LOADS APPLIED TO THIS PRODUCT MUST BE SUPPORTED BY AUXILIARY STABILIZING STRAPS.

**\*\* FAILURE TO PROPERLY SUPPORT NON-TRAILER LOADS WILL VOID PRODUCT WARRANTY\*\***

HAVING INSTALLATION QUESTIONS? CALL TECHNICAL SUPPORT AT 877-287-8634

| Parts List |     |             |                                    |
|------------|-----|-------------|------------------------------------|
| ITEM       | QTY | PART NUMBER | DESCRIPTION                        |
| 1          | 2   | 10-10465    | U-BOLT,3/8-16 UNC,1-9/16,N/A,ZP    |
| 2          | 4   | 30-00148    | WASHER,S-CON,3/8,YZ                |
| 3          | 4   | 20-00166    | NUT,HEX,3/8-16 UNC,GRD8,YZ         |
| 4          | 6   | 30-00195    | WASHER,FLAT,5/16,YZ                |
| 5          | 4   | 10-10549    | HHCS,5/16-18 UNC,2,GRD8,YZ         |
| 6          | 4   | 20-00101    | NUT,SER-FLANGE,5/16-18 UNC,GRD8,YZ |

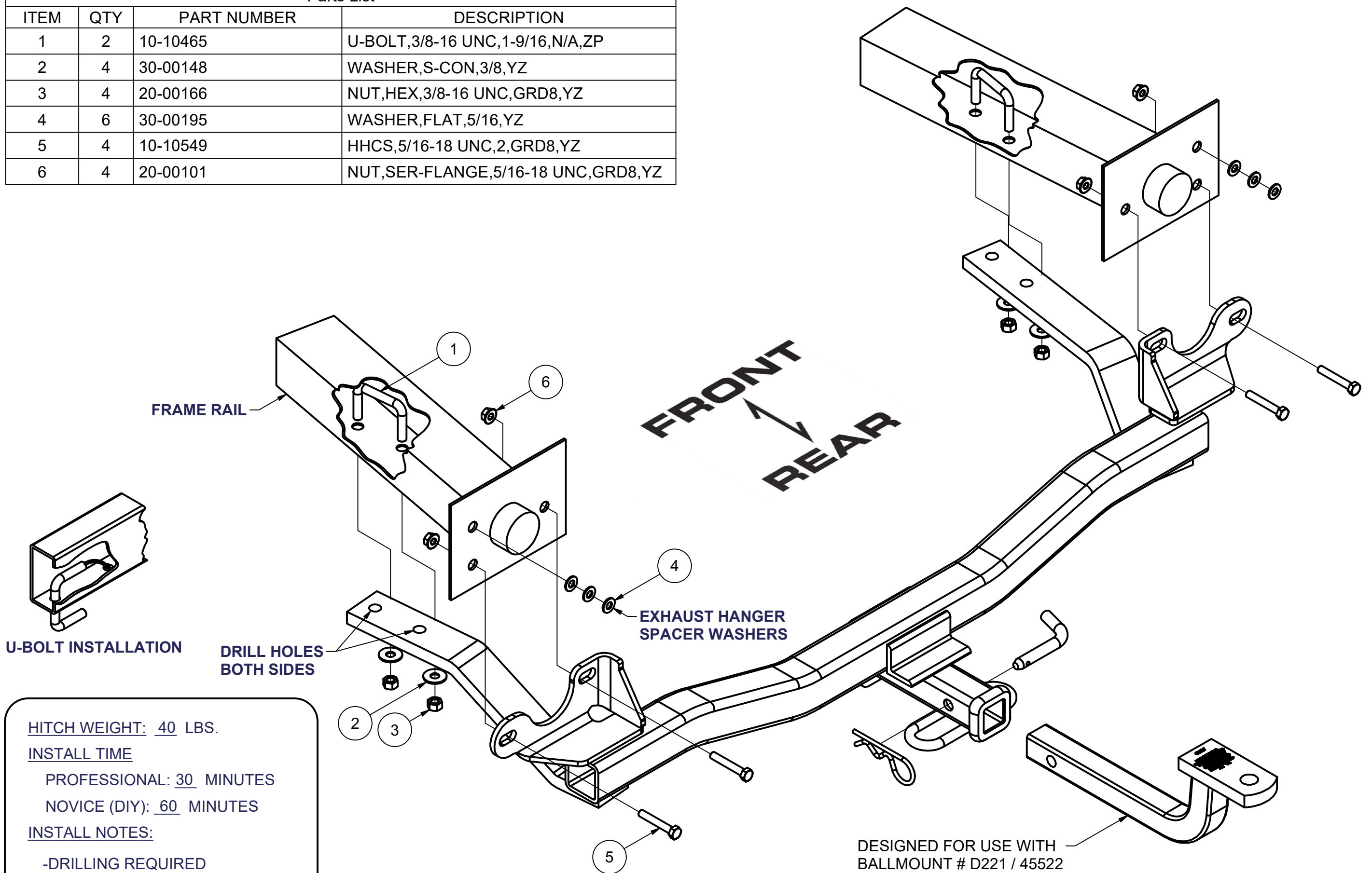

HITCH WEIGHT: 40 LBS.

INSTALL TIME

PROFESSIONAL: 30 MINUTES

NOVICE (DIY): 60 MINUTES

INSTALL NOTES:

-DRILLING REQUIRED

## INSTALLATION STEPS

- 1) Remove inboard and lower outboard energy absorber (E/A) unit mounting bolts from both sides of frame. Remove the upper outboard bolt that attaches the exhaust hanger bracket to end of the frame on driver and passenger side.
- 2) Position the hitch on the vehicle as shown and loosely install the 5/16" bolts provided. Use the hitch side arms as a template to drill four 1/2" holes. **(Note: The side arms must sit flat against the vehicle frame. Chisel or drill out rivets holding heat shield under side arms if required. Also, bend heat shield if needed.)**
- 3) Lower side arms and insert the 3/8" U-bolts through the frame as shown. Raise side arms into position and install the 3/8" conical washers and nuts on the U-bolts. **(Note: Driver side exhaust hanger bracket must be reattached through the opening in the hitch upright before reattaching shoulder bolt. This will require washers to be used as spacers between the bracket and vehicle.**
- 4) Use three 5/16" flat washers provided to shim space between exhaust bracket and the upper outboard attachment for E/A unit on driver's and passengers side. Use existing fasteners to reattach exhaust hanger bracket. Deformation of sheet metal flanges on E/A mounting surfaces is permissible when fasteners are tightened.
- 5) Some models may require bending exhaust hanger on passenger side for required clearance.
- 6) Torque 5/16 fasteners to 24 lb.-ft. Torque 3/8" fasteners to 45 lb.-ft.

**PERIODICALLY CHECK THIS RECEIVER HITCH TO ENSURE THAT ALL FASTENERS ARE TIGHT AND THAT ALL STRUCTURAL COMPONENTS ARE SOUND.**

Curt Manufacturing Inc., warrants this product to be free of defects in material and/or workmanship at the time of retail purchase by the original purchaser. If the product is found to be defective, Curt Manufacturing Inc., may repair or replace the product, at their option, when the product is returned, prepaid, with proof of purchase. Alteration to, misuse of, or improper installation of this product voids the warranty. Curt Manufacturing Inc.'s liability is limited to repair or replacement of products found to be defective, and specifically excludes liability for incidental or consequential loss or damage.