

12069

88-96 PONTIAC GRAND PRIX 2 & 4 DR (EXCEPT SE),
88-97 OLDSMOBILE CUTLASS SUPREME 2 & 4 DR & BUICK REGAL PASSENGER (FWD),
90-94 CHEVROLET LUMINA PASSENGER (EXCEPT Z34)

1/25/2021

GROSS LOAD CAPACITY WHEN USED AS A WEIGHT CARRYING HITCH: 3500 LBS. TRAILER WEIGHT & 350 LBS. TONGUE WEIGHT.
*****DO NOT EXCEED VEHICLE MANUFACTURER'S RECOMMENDED TOWING CAPACITY.*****

Parts List			
ITEM	QTY	PART NUMBER	DESCRIPTION
1	2	CM-SP140	.250" SPACER
2	12	20-00103	NUT,SER-FLANGE,7/16-14 UNC,GRD8,YZ
3	12	10-10282	BOLT,CAR,7/16-14 UNC,1-1/2,GRD8,YZ
4	1	12069 TEMPLATE	DRILL TEMPLATE

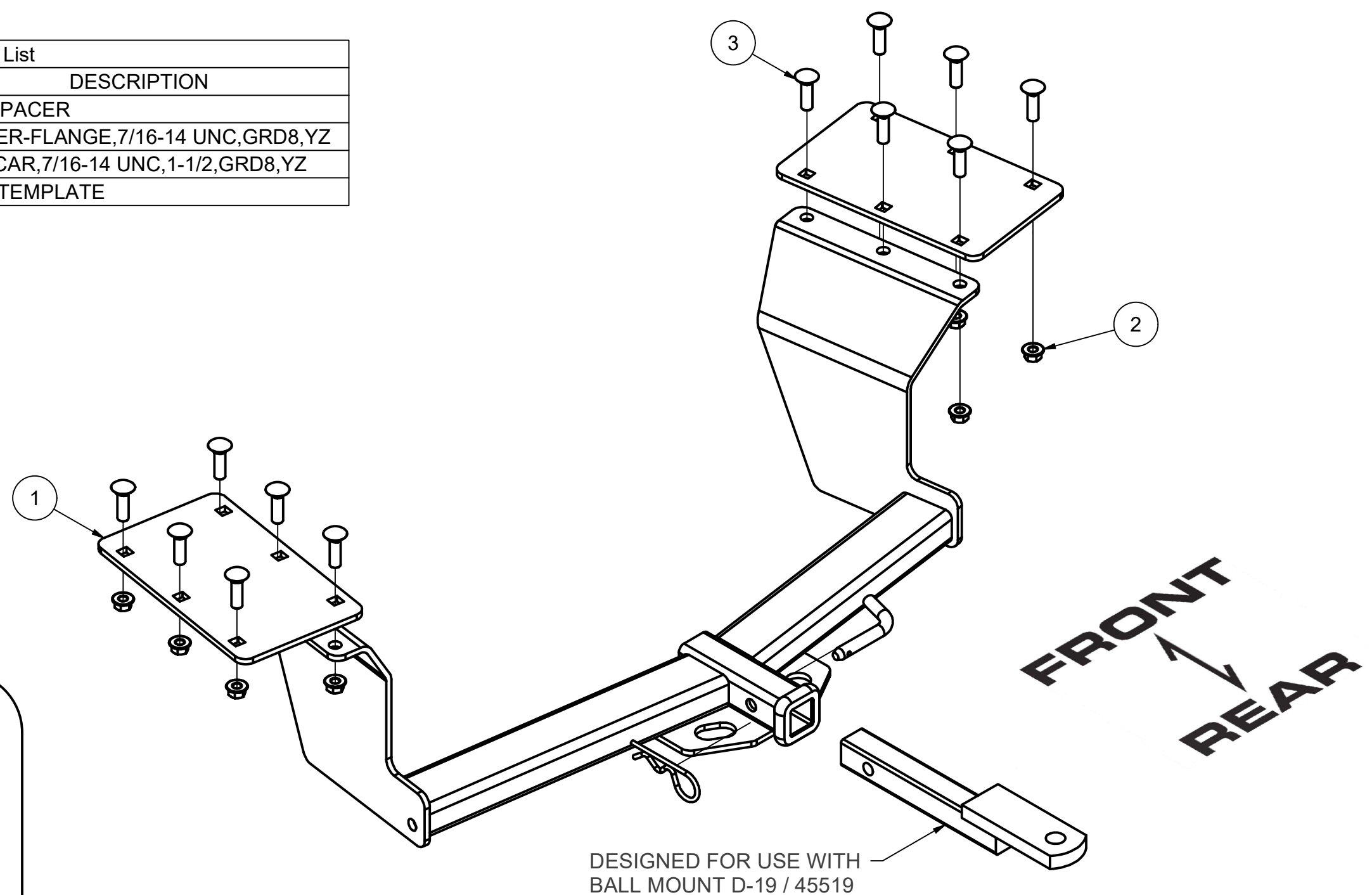

HITCH WEIGHT: 49 LBS.

INSTALL TIME: 60 MINUTES

INSTALL NOTES:

LOWER EXHAUST
DRILLING RQD.....

INSTALLATION STEPS

For models with dual mufflers:

- 1) Lower both mufflers and remove the (two) plastic tow pads connected to the bottom of the bumper & return to customer.
- 2) Lower passenger side muffler and remove exhaust shield, for wrench access.
- 3) Remove vertical panel at rear of inside of trunk. Move carpet and remove spare tire cover, for access to trunk pan. It will be necessary to unglue carpet on passenger side.

The 12069 template

- * Cut or fold template along the (2) parallel dashed lines.
 - * Place template inside trunk on passenger side of spare tire well.
 - * Template should be positioned so that the arrows line up with the centers of the ribs in the trunk pan.
 - * Tape template in place once all the arrows are lined up.
- 4) Center punch three places as specified on the template. Remove and drill (3) 1/8" holes where centered punched. Check hole alignment under vehicle & adjust as necessary. Enlarge the 1/8" holes to 9/16" holes.
 - 5) Position reinforcement plate inside trunk, between two rows of ribs, so that the holes in the plate line up w/ holes drilled in step 4.
 - 6) Position hitch on vehicle. Install 7/16" carriage bolts through reinforcement plate and trunk pan into hitch. Fasten with washers and nuts. Assemble driver side as described in steps 4 thru 6.
 - 7) Using reinforcement plate as template, drill 9/16" holes through trunk pan at remaining holes in plate. Install (3) 7/16" carriage bolts and fasten w/ washers and nuts. Repeat for opposite side.
 - 8) Torque 7/16" fasteners to 70 LB.-FT.

Note: Seal all holes drilled in trunk to prevent entry of exhaust fumes.

9) Reinstall exhaust shield and connect both mufflers.

10) Reglue carpet pad inside trunk on passenger side. Replace inside trunk panel, spare tire cover, and carpeting removed in step 3.

PERIODICALLY CHECK THIS RECEIVER HITCH TO ENSURE THAT ALL FASTENERS ARE TIGHT AND THAT ALL STRUCTURAL COMPONENTS ARE SOUND.

Curt Manufacturing Inc., warrants this product to be free of defects in material and/or workmanship at the time of retail purchase by the original purchaser. If the product is found to be defective, Curt Manufacturing Inc., may repair or replace the product, at their option, when the product is returned, prepaid, with proof of purchase. Alteration to, misuse of, or improper installation of this product voids the warranty. Curt Manufacturing Inc.'s liability is limited to repair or replacement of products found to be defective, and specifically excludes liability for incidental or consequential loss or damage.