

12068

1995 - 2002 CADILLAC ELDORADO

1/25/2021

GROSS LOAD CAPACITY WHEN USED AS A WEIGHT CARRYING HITCH: 3,500 LBS. TRAILER WEIGHT & 300 LBS. TONGUE WEIGHT.

*****DO NOT EXCEED VEHICLE MANUFACTURER'S RECOMMENDED TOWING CAPACITY.*****

WARNING: ALL NON-TRAILER LOADS APPLIED TO THIS PRODUCT MUST BE SUPPORTED BY AUXILIARY STABILIZING STRAPS.

**** FAILURE TO PROPERLY SUPPORT NON-TRAILER LOADS WILL VOID PRODUCT WARRANTY****

HAVING INSTALLATION QUESTIONS? CALL TECHNICAL SUPPORT AT 1-877-287-8634

Parts List			
ITEM	QTY	PART NUMBER	DESCRIPTION
1	4	10-10549	HHCS,5/16-18 UNC,2,GRD8,YZ
2	4	30-00195	WASHER,FLAT,5/16,YZ
3	4	20-00206	NUT,FLANGE,5/16-18 UNC,GRD8,YZ
4	2	10-10288	BOLT,CAR,1/2-13 UNC,2,GRD8,YZ
5	2	CM-SP10	.25 x 1.00 x 2.50 SQ. HOLE SPACER
6	2	20-00062	NUT, SER-FLANGE,1/2-13 UNC,GRD8,YZ
7	2	1_2 FISHWIRE	1/2" FISHWIRE

TOOLS REQUIRED

1/2" WRENCH
1/2" AND 3/4" SOCKETS
10" EXTENSION
SOCKET WRENCH
TORQUE WRENCH

FISHWIRE TECHNIQUE

INSERT COILED END OF FISHWIRE TOOL THROUGH HITCH MOUNTING HOLE IN VEHICLE FRAME RAIL AND OUT THE ACCESS HOLE. PASS COILED END OF FISHWIRE THROUGH SPACER AND THREAD BOLT INTO COIL. KINK WIRE TO KEEP SPACER SEPARATE FROM BOLT AS SHOWN. PULL FISHWIRE, SPACER, AND BOLT THROUGH FRAME AND OUT MOUNTING HOLE. USE FISHWIRE TO GUIDE HITCH DURING MOUNTING AND PREVENT LOSS OF BOLT / SPACER INSIDE FRAME RAIL.

NOTE: SOME VEHICLES MAY FISHWIRE THROUGH END OF FRAME

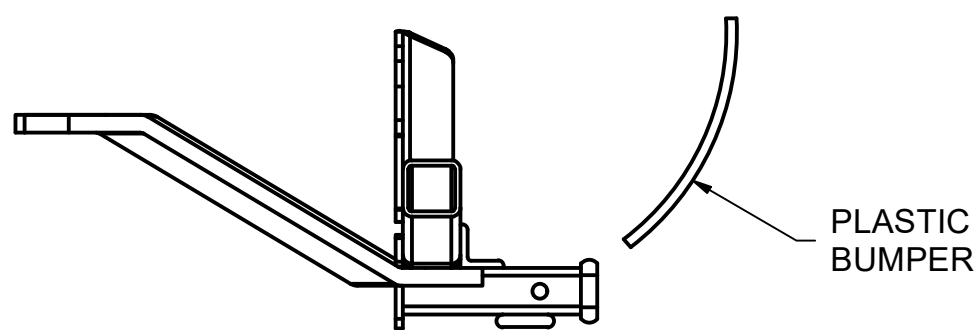

INSTALLED HITCH POSITION

HITCH WEIGHT: 49 LBS.

INSTALL TIME: 30 MINUTES

INSTALL NOTES:

- NO DRILLING REQUIRED
- LOWER EXHAUST
- FISHWIRE HARDWARE
- FASCIA TRIMMING MAY BE REQUIRED ON SOME MODELS

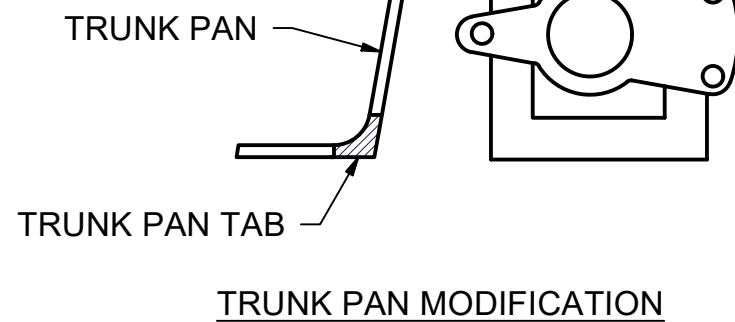

TRUNK PAN MODIFICATION

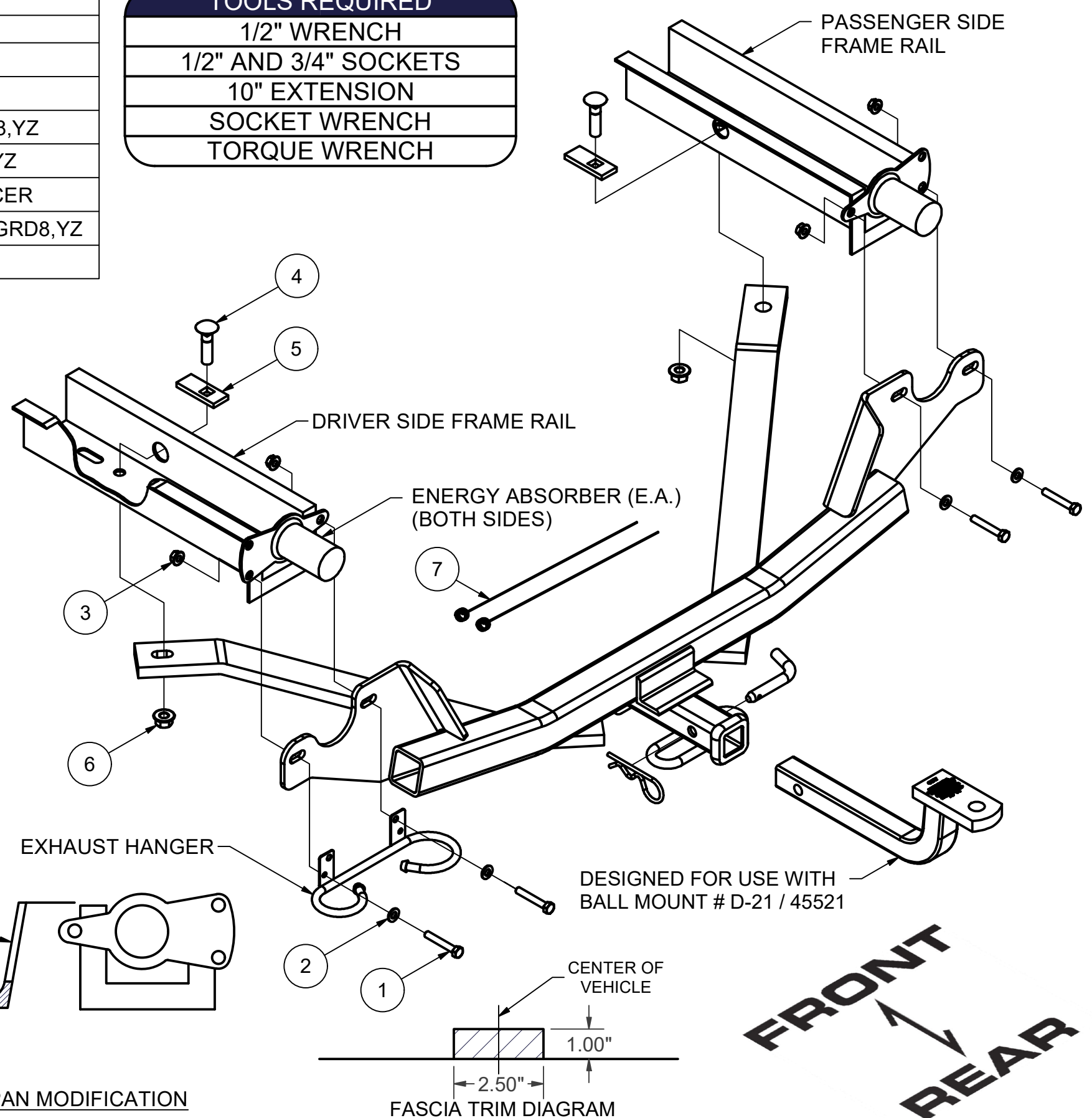

INSTALLATION STEPS

1. On models with dual exhaust pipes, or exhaust hangers at the Energy Absorber (E.A.) units, lower the mufflers and tail pipes. Support muffler assembly with a wire or jack to prevent excess travel which could be damaging to the exhaust system.
 2. Remove the bottom outboard E.A. bolt and inboard E.A. bolt from both sides. Return the bolts to the vehicle owner.
 3. Fishwire a CM-SP10 spacer and 1/2-13 carriage bolt through the access hole on the inside of the frame rail into the third slot from the end of the frame rail on both sides. Leave fishwires attached. (See Fishwire Technique.)
 4. Raise the hitch into position between the E.A. unit and the exhaust hanger (if present) and install the 5/16" hex bolts, washers and flange nuts as shown. Feed the 1/2" fishwires through the slots in the mounting strap, taking care not to push the carriage bolts into the frame rails.
- Note: Bend the trunk pan tabs as shown in "Trunk Pan Modification" to eliminate interference.
5. Remove the fishwires from the 1/2" carriage bolts in the frame rails and secure the hitch to the frame rails with 1/2" hex flange nuts as shown.
 6. Torque all 5/16" hardware to 24 ft-lbs. Torque all 1/2" hardware to 110 ft-lbs.
 7. Reattach the muffler and tail pipes if lowered in Step 1.

PERIODICALLY CHECK THIS RECEIVER HITCH TO ENSURE THAT ALL FASTENERS ARE TIGHT AND THAT ALL STRUCTURAL COMPONENTS ARE SOUND.

Curt Manufacturing Inc., warrants this product to be free of defects in material and/or workmanship at the time of retail purchase by the original purchaser. If the product is found to be defective, Curt Manufacturing Inc., may repair or replace the product, at their option, when the product is returned, prepaid, with proof of purchase. Alteration to, misuse of, or improper installation of this product voids the warranty. Curt Manufacturing Inc.'s liability is limited to repair or replacement of products found to be defective, and specifically excludes liability for incidental or consequential loss or damage.