

12058

00-05 CADILLAC DEVILLE AND 06-PRESENT DTS

8/13/2020

GROSS LOAD CAPACITY WHEN USED AS A WEIGHT CARRYING HITCH: 3500 LBS. TRAILER WEIGHT & 350 LBS. TONGUE WEIGHT.

\*\*\*DO NOT EXCEED VEHICLE MANUFACTURER'S RECOMMENDED TOWING CAPACITY.\*\*\*

WARNING: ALL NON-TRAILER LOADS APPLIED TO THIS PRODUCT MUST BE SUPPORTED BY AUXILIARY STABILIZING STRAPS.

\*\* FAILURE TO PROPERLY SUPPORT NON-TRAILER LOADS WILL VOID PRODUCT WARRANTY\*\*

HAVING INSTALLATION QUESTIONS? CALL TECHNICAL SUPPORT AT 877-287-8634

Parts List			
ITEM	QTY	PART NUMBER	DESCRIPTION
1	4	10-10272	BOLT,CAR,1/2-13 UNC,1-3/4,GRD8,YZ
2	2	10-10393	HHCS,M8x1.25,35,CL10.9,YZ
3	4	20-00062	NUT, SER-FLANGE,1/2-13 UNC,GRD8,YZ
4	2	30-00148	WASHER,S-CON,3/8,YZ
5	4	CM-SP6	.250 x 1.00 x 3.00" SQUARE HOLE SPACER
6	1	1_2 FISHWIRE	1/2" FISHWIRE

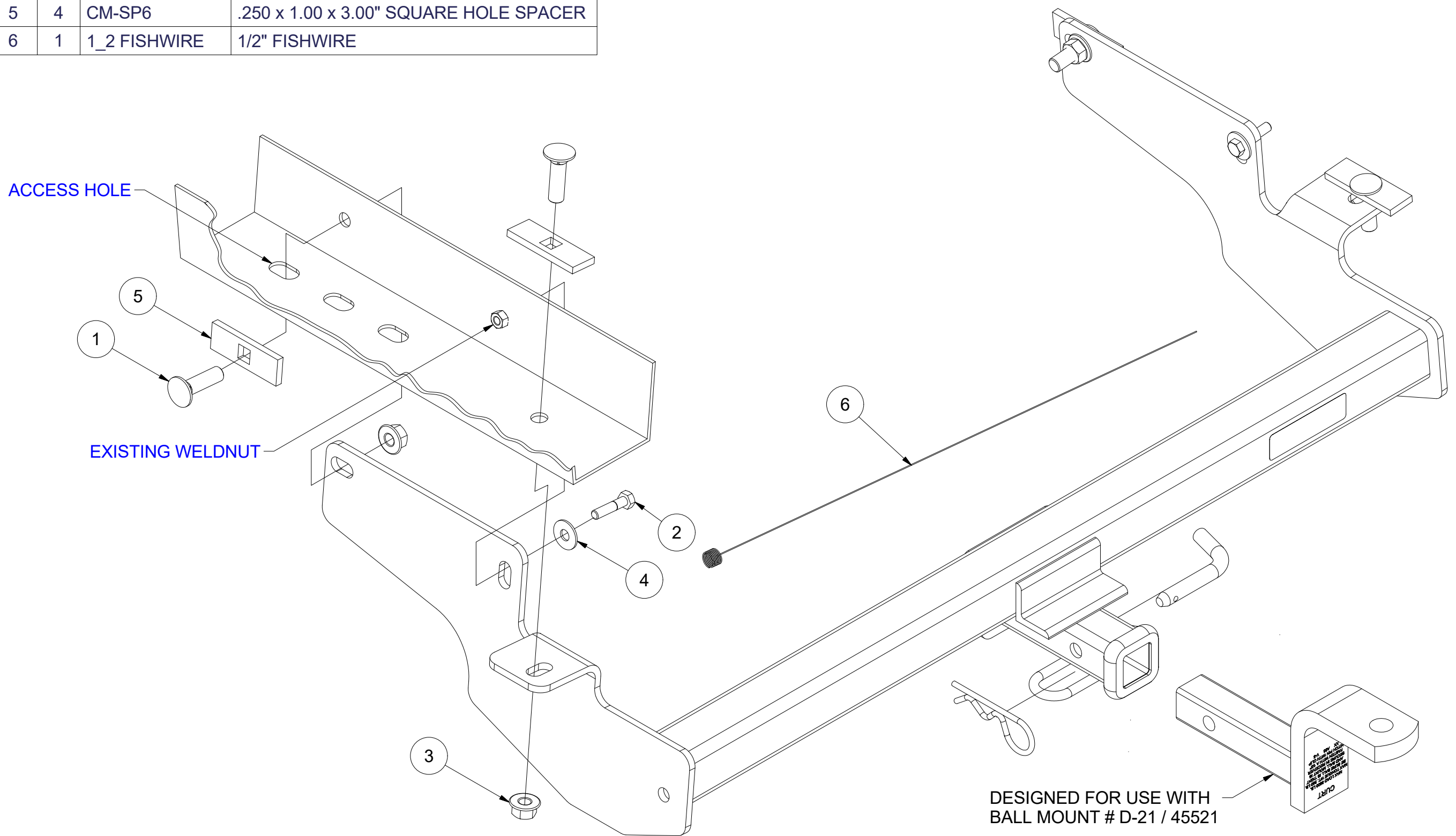

HITCH WEIGHT: 27 LBS.  
 INSTALL TIME  
 PROFESSIONAL: 20 MINUTES  
 NOVICE (DIY): 40 MINUTES  
 INSTALL NOTES:  
 -NO DRILLING REQUIRED

INSTALLATION STEPS

1. Raise hitch into position.
2. Install two M8 bolts into existing weldnuts as shown.
3. Fishwire remaining fasteners as shown. Note: 1/2" bolt and block must be inserted separately into access hole during fishwiring process.
4. Torque M8 fasteners to 23 lb.-ft. Torque all 1/2" fasteners to 110 lb.-ft.

PERIODICALLY CHECK THIS RECEIVER HITCH TO ENSURE THAT ALL FASTENERS ARE TIGHT AND THAT ALL STRUCTURAL COMPONENTS ARE SOUND.

Curt Manufacturing Inc., warrants this product to be free of defects in material and/or workmanship at the time of retail purchase by the original purchaser. If the product is found to be defective, Curt Manufacturing Inc., may repair or replace the product, at their option, when the product is returned, prepaid, with proof of purchase. Alteration to, misuse of, or improper installation of this product voids the warranty. Curt Manufacturing Inc.'s liability is limited to repair or replacement of products found to be defective, and specifically excludes liability for incidental or consequential loss or damage.