

12056**MERCEDES-BENZ R-320/R350/R500**

1/22/2014

GAS ONLY

GROSS LOAD CAPACITY WHEN USED AS A WEIGHT CARRYING HITCH: 2,500 LBS. TRAILER WEIGHT & 250 LBS. TONGUE WEIGHT.

DO NOT EXCEED VEHICLE MANUFACTURER'S RECOMMENDED TOWING CAPACITY.

WARNING: ALL NON-TRAILER LOADS APPLIED TO THIS PRODUCT MUST BE SUPPORTED BY AUXILIARY STABILIZING STRAPS.

** FAILURE TO PROPERLY SUPPORT NON-TRAILER LOADS WILL VOID PRODUCT WARRANTY**

HAVING INSTALLATION QUESTIONS? CALL TECHNICAL SUPPORT AT 1-877-287-8634

Parts List

ITEM	QTY	PART NUMBER	DESCRIPTION
1	8	3_8 - 16 x 5 1_2 HEX	HEX BOLT
2	8	3/8"	CONICAL TOOTHED WASHER

**RUBBER ISOLATOR
REMOVAL DIAGRAM**

This technique can be used if and Exhaust Hanger Removal Pliers is not available.

Using a 5/8" open end wrench, slide the wrench up to the rubber isolator, cradling the hanger rod as shown. Next place the flat edge of a pry bar between the wrench and the hanger stop or hanger rod. Then simply rotate the pry bar toward the wrench to remove the rubber isolator.

Note: Using a spray lubricant or soapy water on the hanger rod and the rubber isolator helps removal.

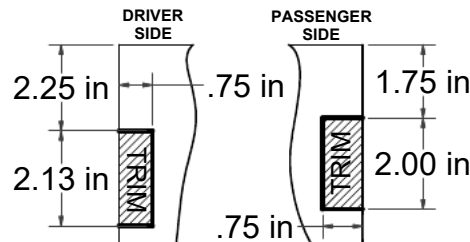
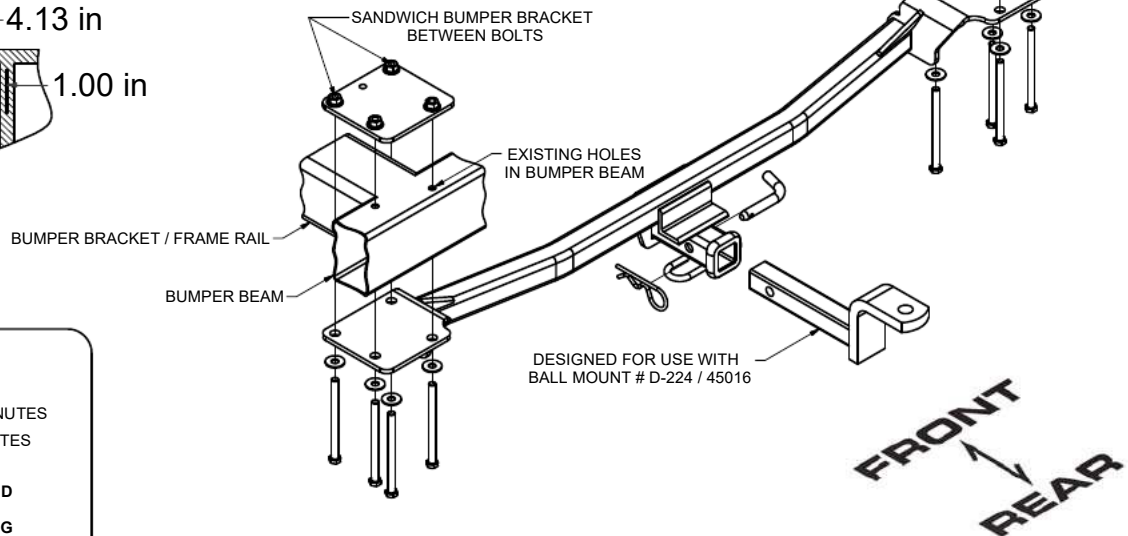
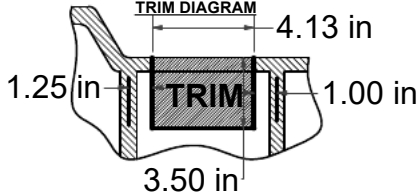
**MAIN BODY CLEARANCE
TRIM DIAGRAM****RECEIVER TUBE CLEARANCE
TRIM DIAGRAM**

HITCH WEIGHT: .31 LBS.

INSTALL TIME

PROFESSIONAL: 60 MINUTES

NOVICE (DIY): 120 MINUTES

INSTALL NOTES:

- REMOVE TRUNK SHROUD
- LOWER EXHAUST
- TRUNK SHIELD TRIMMING REQUIRED

INSTALLATION STEPS

1. Remove (4) 6mm x 1.0 and (7) plastic nuts that hold on the plastic trunk shield.
2. Lower exhaust on both sides by removing the (4) rearmost exhaust hangers.
3. Remove (2) carriage bolts from bumper beam, both sides.
4. Place backing plates above bumper beam as shown.
5. Raise hitch into position, and loosely install supplied hex bolts and conical toothed washers as shown.
6. Torque all 3/8" fasteners to 30 lb-ft.
7. Reinstall exhaust hangers.
8. When reinstalling plastic shield, trimming is required as shown in above diagrams. If customer chooses to omit the shield, return to customer.

PERIODICALLY CHECK THIS RECEIVER HITCH TO ENSURE THAT ALL FASTENERS ARE TIGHT AND THAT ALL STRUCTURAL COMPONENTS ARE SOUND.

Curt Manufacturing Inc., warrants this product to be free of defects in material and/or workmanship at the time of retail purchase by the original purchaser. If the product is found to be defective, Curt Manufacturing Inc., may repair or replace the product, at their option, when the product is returned, prepaid, with proof of purchase. Alteration to, misuse of, or improper installation of this product voids the warranty. Curt Manufacturing Inc.'s liability is limited to repair or replacement of products found to be defective, and specifically excludes liability for incidental or consequential loss or damage.