

12044

00-05 BUICK LE SABRE- ALL MODELS, 06-CURRENT BUICK LUCERNE
00-05 PONTIAC BONNEVILLE- ALL(EXCEPT SLE), 00-03 OLDSMOBILE AURORA

8/18/2020

GROSS LOAD CAPACITY WHEN USED AS A WEIGHT CARRYING HITCH: 3,500 LBS. TRAILER WEIGHT & 350 LBS. TONGUE WEIGHT.

DO NOT EXCEED VEHICLE MANUFACTURER'S RECOMMENDED TOWING CAPACITY.

WARNING: ALL NON-TRAILER LOADS APPLIED TO THIS PRODUCT MUST BE SUPPORTED BY AUXILIARY STABILIZING STRAPS.

** FAILURE TO PROPERLY SUPPORT NON-TRAILER LOADS WILL VOID PRODUCT WARRANTY**

HAVING INSTALLATION QUESTIONS? CALL TECHNICAL SUPPORT AT 1-877-287-8634

Parts List			
ITEM	QTY	PART NUMBER	DESCRIPTION
1	2	10-10272	BOLT,CAR,1/2-13 UNC,1-3/4,GRD8,YZ
2	2	CM-SP6	.250 x 1.00 x 3.00" SPACER
3	2	20-00062	NUT, SER-FLANGE,1/2-13 UNC,GRD8,YZ
4	1	1_2 FISHWIRE	1/2" FISHWIRE
5	2	30-00148	WASHER,S-CON,3/8,YZ
6	2	10-10414	HHCS,M10x1.5,45,CL10.9,YZ
7	2	3/8-16	NUT,SER-FLANGE,3/8-16 UNC,GRD8,YZ
8	2	10-10323	BOLT,CAR,3/8-16 UNC,2,GRD8,YZ
9	2	CM-12044-EHB	.250" EXHAUST HANGER BRACKET

TOOLS REQUIRED
17/32 DRILL BIT
DRILL
17mm, 9/16 & 3/4 SOCKETS
10" EXTENSION
RATCHET
TORQUE WRENCH

FISHWIRE TECHNIQUE
 INSERT COILED END OF FISHWIRE TOOL THROUGH HITCH MOUNTING HOLE IN VEHICLE FRAME RAIL AND OUT THE ACCESS HOLE. PASS COILED END OF FISHWIRE THROUGH SPACER AND THREAD BOLT INTO COIL. KINK WIRE TO KEEP SPACER SEPARATE FROM BOLT AS SHOWN. PULL FISHWIRE, SPACER, AND BOLT THROUGH FRAME AND OUT MOUNTING HOLE. USE FISHWIRE TO GUIDE HITCH DURING MOUNTING AND PREVENT LOSS OF BOLT / SPACER INSIDE FRAME RAIL.
 NOTE: SOME VEHICLES MAY FISHWIRE THROUGH END OF FRAME

RUBBER ISOLATOR REMOVAL DIAGRAM
 This technique can be used if an Exhaust Hanger Removal Pliers is not available.
 Using a 5/8" open end wrench, slide the wrench up to the rubber isolator, cradling the hanger rod as shown. Next place the flat edge of a pry bar between the wrench and the hanger stop or hanger rod. Then simply rotate the pry bar toward the wrench to remove the rubber isolator.
 Note: Using a spray lubricant or soapy water on the hanger rod and the rubber isolator helps removal.

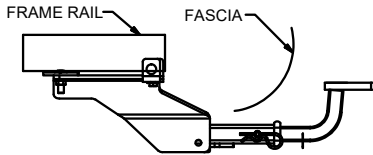

HITCH SHOWN PROPERLY INSTALLED

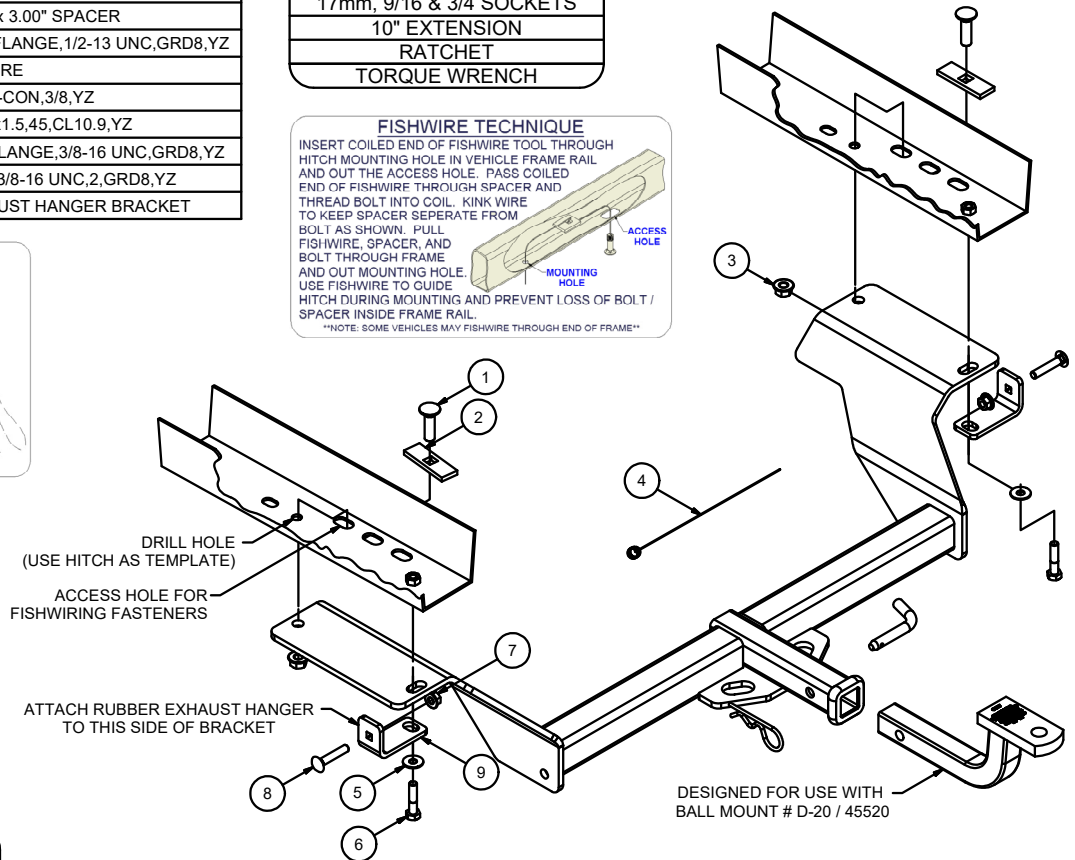

HITCH WEIGHT: 32 LBS.

INSTALL TIME

PROFESSIONAL: 30 MINUTES

NOVICE (DIY): 60 MINUTES

INSTALL NOTES:

-DRILLING REQUIRED

-FISHWIRE HARDWARE

Note: On vehicles equipped with heat shield, remove rearmost fastener which secures heat shield to frame rail and discard. Trim heat shield as needed.

Note: On vehicles equipped with automatic load leveling control, remove rearmost fastener which secures load leveling control housing to frame rail and discard. Trim load leveling control housing as needed.

INSTALLATION STEPS

- 1) Remove the exhaust hanger bracket from the bottom of the frame rail and disconnect the rubber hanger attached to the exhaust tail pipe. A replacement bracket is provided and will be installed later. Return factory exhaust brackets to the vehicle owner. (See Rubber Isolator Removal Diagram)
- 2) When lifting hitch into position you may need to bend or cut heat shield to allow for hitch clearance, temporarily attach to vehicle with hex bolts. Using hitch as a template drill two 17/32" holes as shown above.
- 3) Lower hitch and fishwire carriage bolts and spacers through frame access holes. (See Fishwire Technique Diagram)
- 4) Attach hanger brackets, install M10 hex bolt through square hole in bracket to bottom of frame. Slide the rubber hanger onto the 3/8" carriage bolt and secure with flanged hex nut. Tighten nut against the rubber hanger allowing the hanger to rotate. Do not over tighten.
- 5) Torque all M10 fasteners to 45 ft.-lbs. Torque all 1/2" fasteners to 110 ft.-lbs.

PERIODICALLY CHECK THIS RECEIVER HITCH TO ENSURE THAT ALL FASTENERS ARE TIGHT AND THAT ALL STRUCTURAL COMPONENTS ARE SOUND.

Curt Manufacturing Inc., warrants this product to be free of defects in material and/or workmanship at the time of retail purchase by the original purchaser. If the product is found to be defective, Curt Manufacturing Inc., may repair or replace the product, at their option, when the product is returned, prepaid, with proof of purchase. Alteration to, misuse of, or improper installation of this product voids the warranty. Curt Manufacturing Inc.'s liability is limited to repair or replacement of products found to be defective, and specifically excludes liability for incidental or consequential loss or damage.