

**11830****98-03 MERCEDES BENZ E320**

11/13/2017

GROSS LOAD CAPACITY WHEN USED AS A WEIGHT CARRYING HITCH: 2,000 LBS. TRAILER WEIGHT &amp; 200 LBS. TONGUE WEIGHT.

**\*\*\*DO NOT EXCEED VEHICLE MANUFACTURER'S RECOMMENDED TOWING CAPACITY.\*\*\***

WARNING: ALL NON-TRAILER LOADS APPLIED TO THIS PRODUCT MUST BE SUPPORTED BY 18050 STABILIZING STRAPS.

**\*\* FAILURE TO PROPERLY SUPPORT NON-TRAILER LOADS WILL VOID PRODUCT WARRANTY\*\***

HAVING INSTALLATION QUESTIONS? CALL TECHNICAL SUPPORT AT 1-800-798-0813

Parts List			
ITEM	QTY	PART NUMBER	DESCRIPTION
1	8	7/16-14 x 1 1/2	HEX BOLT
2	16	7/16 WASHER	WASHER
3	8	7/16 LOCK WASHER	HELICAL LOCK WASHER
4	8	7/16-14	HEX NUT

**FRONT**  
↕  
**REAR**

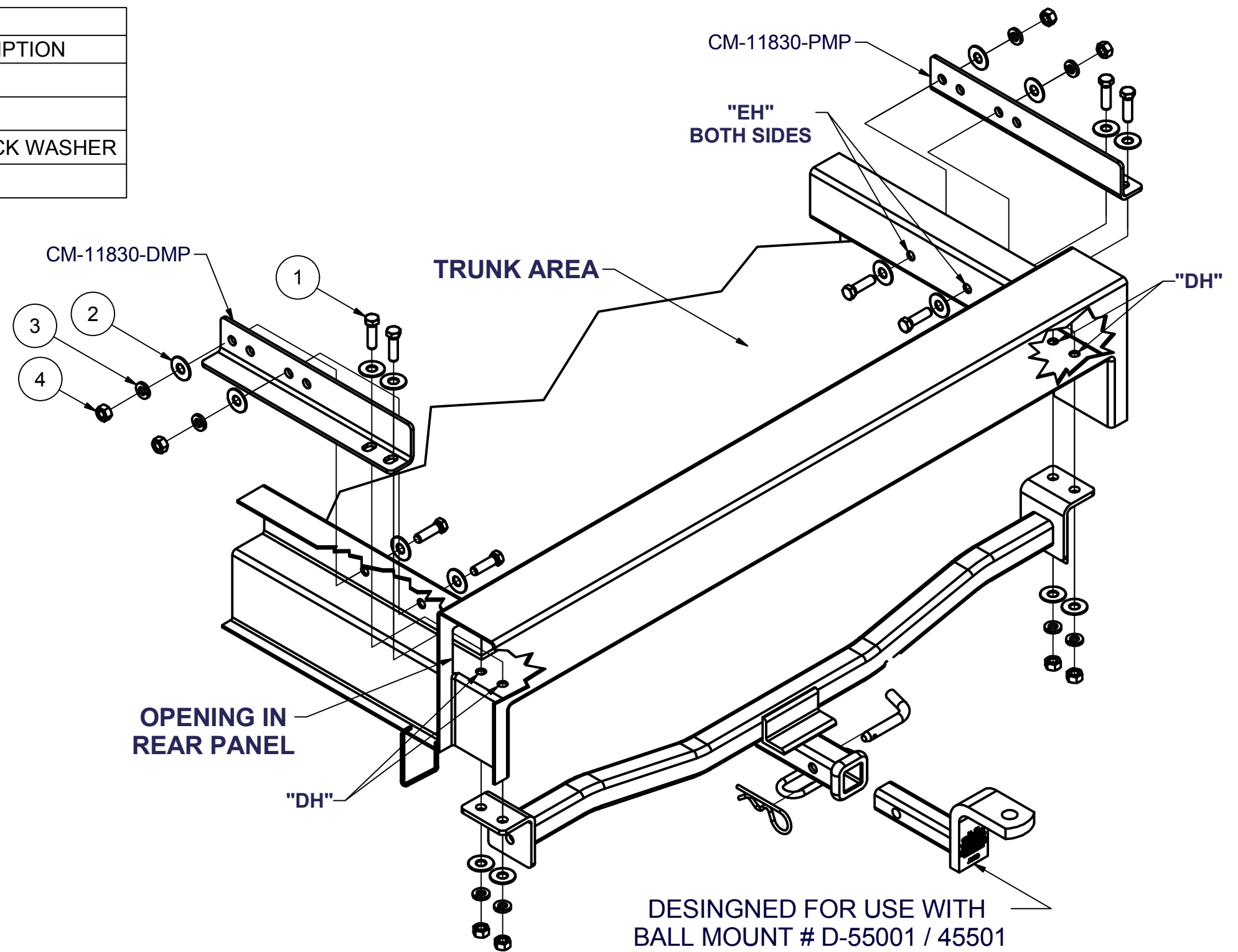
**"EH" = EXISTING HOLES****"DH" = DRILLED HOLES**

HITCH WEIGHT: 28 LBS.

INSTALL TIME

PROFESSIONAL: 60 MINUTES

NOVICE (DIY): 120 MINUTES

INSTALL NOTES:

- DRILLING REQUIRED
- TEMPORARILY REMOVE SPARE TIRE
- TEMPORARILY REMOVE PANELS
- SILICONE SEAL HARDWARE

**INSTALLATION STEPS**

1. The trunk area is split into (3) areas, the main trunk, and two smaller side cavities. Remove the panels on these side cavities, then remove the spare tire from the driver side and anything that is in the passenger side. (Ex. "CD" player, remove CD player take out the 3 screws holding it and carefully slide it out. Undo the carpet clips from the sides of the trunk to expose the holes that are needed to attach the mounting brackets.)
2. In the cavities locate the "C" shaped frame rail, the mounting bracket fits in here with the wide flange down. Slide bracket rearward through the opening in the channel until the round holes in the bracket properly line up with the existing holes. Both slots will be inside the rear opening when in position. (NOTE- some factory body filler may be in the openings for the brackets; clean this out so the bracket may sit flat on the frame.)
3. Once the bracket is in position insert the 7/16" hardware provided as shown but do not tighten.
4. Position the hitch under the back of the car just behind the bumper cover, centered and against the rear most lip in the body. The flat space should be only big enough to fit the hitch. Mark the holes in the hitch and using a 1/8" drill bit, drill two small pilot holes on each side to check for alignment. The holes should be in the slots of the mounting brackets.
5. Once alignment is made drill the holes out to fit the 7/16" hardware and install hitch with hardware as shown.
6. Torque all hardware to 70 ft-lbs.
7. Use silicone sealant to seal hardware installed through trunk.
8. Replace spare tire and all other equipment / panels that were removed.

**PERIODICALLY CHECK THIS RECEIVER HITCH TO ENSURE THAT ALL FASTENERS ARE TIGHT AND THAT ALL STRUCTURAL COMPONENTS ARE SOUND.**

Curt Manufacturing Inc., warrants this product to be free of defects in material and/or workmanship at the time of retail purchase by the original purchaser. If the product is found to be defective, Curt Manufacturing Inc., may repair or replace the product, at their option, when the product is returned, prepaid, with proof of purchase. Alteration to, misuse of, or improper installation of this product voids the warranty. Curt Manufacturing Inc.'s liability is limited to repair or replacement of products found to be defective, and specifically excludes liability for incidental or consequential loss or damage.