

11818 (257237)**95-03 JAGUAR SEDAN XJ6, XJ12, XJ8, XJR**

11/13/2017

GROSS LOAD CAPACITY WHEN USED AS A WEIGHT CARRYING HITCH: 2,000 LBS. TRAILER WEIGHT & 200 LBS. TONGUE WEIGHT.

*****DO NOT EXCEED VEHICLE MANUFACTURER'S RECOMMENDED TOWING CAPACITY.*****

WARNING: ALL NON-TRAILER LOADS APPLIED TO THIS PRODUCT MUST BE SUPPORTED BY 18050 STABILIZING STRAPS.

**** FAILURE TO PROPERLY SUPPORT NON-TRAILER LOADS WILL VOID PRODUCT WARRANTY****

HAVING INSTALLATION QUESTIONS? CALL TECHNICAL SUPPORT AT 1-800-798-0813

Parts List			
ITEM	QTY	PART NUMBER	DESCRIPTION
1	1	1/2-13	HANDLE NUT
2	1	1/2"	LOCK WASHER
3	1	1/2-13 x 1 3/4	HEX BOLT
4	5	7/16 LOCK WASHER	HELICAL LOCK WASHER
5	5	CM-SP7	.250 x 1.00 x 2.00" SQUARE HOLE SPACER
6	5	7/16-14	HEX NUT
7	5	7/16-14 x 1 1/2	CARRIAGE BOLT

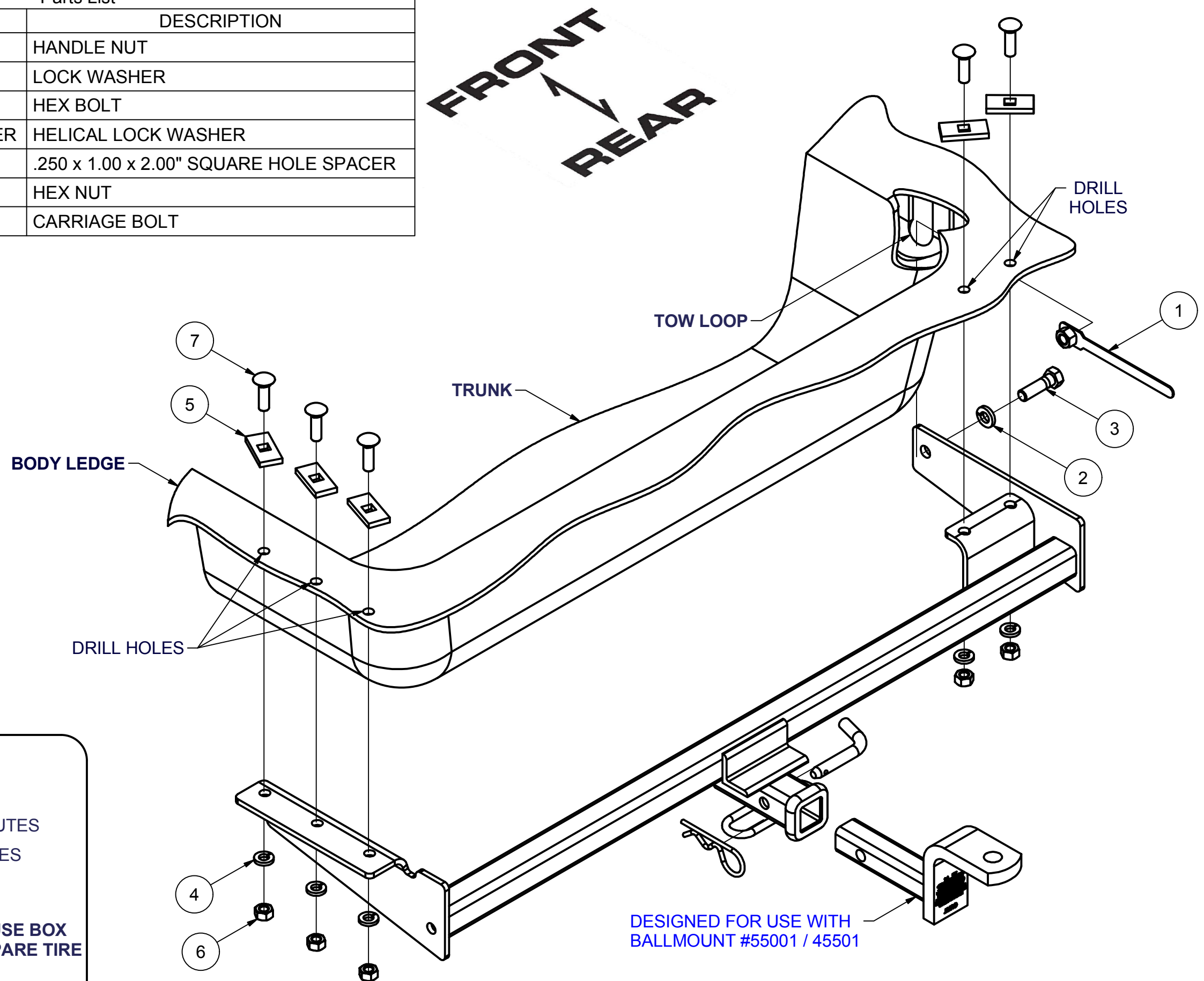

HITCH WEIGHT: 17 LBS.

INSTALL TIME

PROFESSIONAL: 30 MINUTES

NOVICE (DIY): 60 MINUTES

INSTALL NOTES:

- DRILLING REQUIRED
- TEMPORARILY REMOVE FUSE BOX
- TEMPORARILY REMOVE SPARE TIRE COVER
- SILICONE SEAL HARDWARE

INSTALLATION STEPS

1. Temporarily remove cover over the spare tire and inner panel at rear sill. Temporarily remove three mounting screws holding fuse box located just inside rear sill. Fuse box will be remounted in same position with existing hardware after hitch installation.
2. Position the hitch on the vehicle with the cross tube passing rear of trunk and with driver's side plate up against body ledge. Passenger's side plate hole will match existing hole at boxed area where tow loop is attached.
3. Using hitch as a template, mark location for fasteners on ledge and trunk floor area as shown. Remove hitch and drill holes using a 7/16" drill bit.
4. Raise hitch into position on vehicle and install fasteners.
Note: Tab nut is inserted inside boxed area by bending metal cover at front end of boxed area.
5. Torque 7/16" fastener to 70 ft-lbs. and 1/2" fasteners to 110 ft-lbs.
6. Use silicone sealant to seal hardware installed through trunk.
7. Reinstall fuse box and inner panel removed in Step 1.

PERIODICALLY CHECK THIS RECEIVER HITCH TO ENSURE THAT ALL FASTENERS ARE TIGHT AND THAT ALL STRUCTURAL COMPONENTS ARE SOUND.

Curt Manufacturing Inc., warrants this product to be free of defects in material and/or workmanship at the time of retail purchase by the original purchaser. If the product is found to be defective, Curt Manufacturing Inc., may repair or replace the product, at their option, when the product is returned, prepaid, with proof of purchase. Alteration to, misuse of, or improper installation of this product voids the warranty. Curt Manufacturing Inc.'s liability is limited to repair or replacement of products found to be defective, and specifically excludes liability for incidental or consequential loss or damage.