

11805**79-86 MERCEDES BENZ 300 TD WAGON**

6/26/2014

GROSS LOAD CAPACITY WHEN USED AS A WEIGHT CARRYING HITCH: 2,000 LBS. TRAILER WEIGHT & 200 LBS. TONGUE WEIGHT.

*****DO NOT EXCEED VEHICLE MANUFACTURER'S RECOMMENDED TOWING CAPACITY.*******WARNING: ALL NON-TRAILER LOADS APPLIED TO THIS PRODUCT MUST BE SUPPORTED BY AUXILIARY STABILIZING STRAPS.****** FAILURE TO PROPERLY SUPPORT NON-TRAILER LOADS WILL VOID PRODUCT WARRANTY****

HAVING INSTALLATION QUESTIONS? CALL TECHNICAL SUPPORT AT 1-800-798-0813

Parts List			
ITEM	QTY	PART NUMBER	DESCRIPTION
1	2	CM-11805-A	FLAT .50 x 1.50 A-36 H.R.
2	2	CM-11805-BP2WA	WELDMENT ASSEMBLY
3	2	CM-11805-BPWA	WELDMENT ASSEMBLY
4	8	3/8"	LOCK WASHER
5	4	3/8 - 16	HEX NUT
6	2	7/16-14 x 1 1/2	HEX BOLT
7	2	7/16 LOCK WASHER	HELICAL LOCK WASHER
8	2	7/16-14	HEX NUT
9	4	3/8 - 16 x 1 3/4	HEX BOLT
10	4	3/8"	WASHER

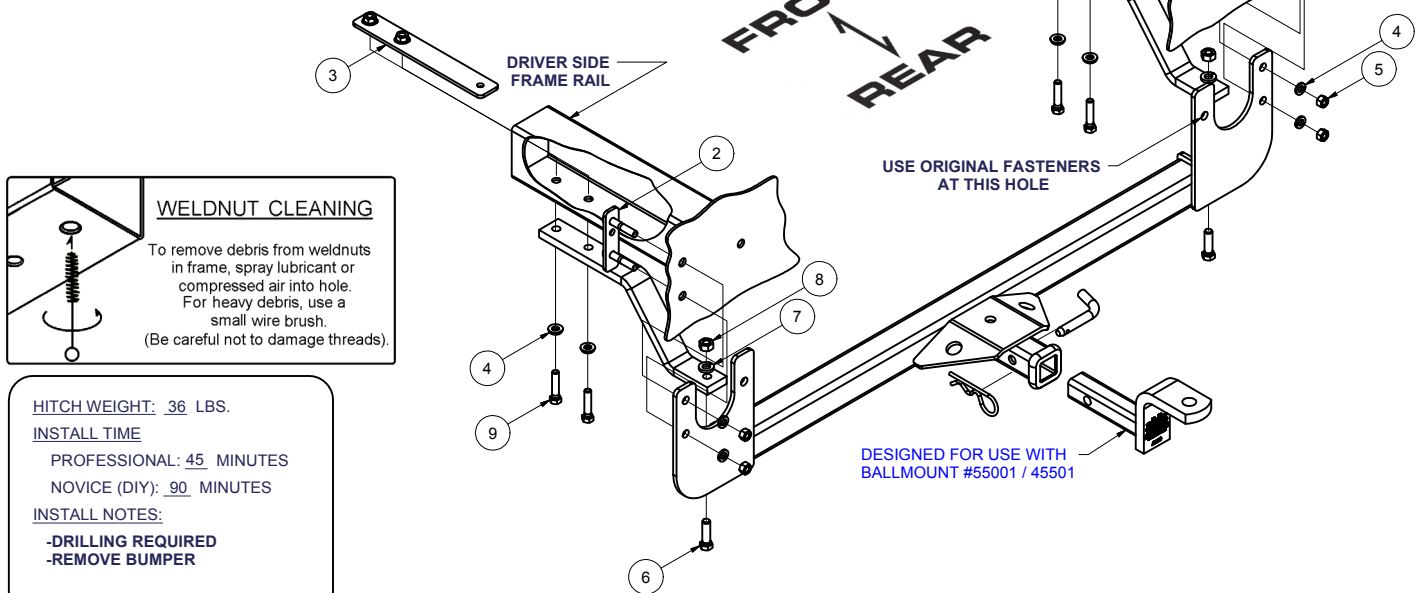
**WELDNUT CLEANING**

To remove debris from weldnuts in frame, spray lubricant or compressed air into hole. For heavy debris, use a small wire brush. (Be careful not to damage threads).

HITCH WEIGHT: 36 LBS.**INSTALL TIME**PROFESSIONAL: 45 MINUTESNOVICE (DIY): 90 MINUTES**INSTALL NOTES:**

- DRILLING REQUIRED
- REMOVE BUMPER

INSTALLATION STEPS

1. Remove the rear bumper by removing both bumper shock strut flanges from the rear of the car's body, leaving struts attached to the bumper.

NOTE: The back-up light wires and grommets should be disconnected and made free from inside the car, before removing bumper. Temporarily remove the spare tire and window washer tank.
2. Install bolt plates through the vertical hitch plates in place of the two outside original screws at each strut flange. Temporarily mount the hitch with nuts shown. Do not install bumper yet.
3. Bolt arm brackets to the hitch frame assembly using fasteners as shown. Using the hitch as a template, drill the bottom surface of the car frame two places per side. Install one backing plate per side into the box frame at the body opening and install the balance of the fasteners.
4. Remove the nuts in the vertical plate and reinstall the rear bumper at the struts at three holes on each side. Use original fasteners in empty hole. Carefully reinstall the back-up light wire and grommets as bumper is replaced.
5. Torque all 3/8" fasteners to 45 lb-ft, and all 7/16" fasteners to 70 lb-ft.

PERIODICALLY CHECK THIS RECEIVER HITCH TO ENSURE THAT ALL FASTENERS ARE TIGHT AND THAT ALL STRUCTURAL COMPONENTS ARE SOUND.

Curt Manufacturing Inc., warrants this product to be free of defects in material and/or workmanship at the time of retail purchase by the original purchaser. If the product is found to be defective, Curt Manufacturing Inc., may repair or replace the product, at their option, when the product is returned, prepaid, with proof of purchase. Alteration to, misuse of, or improper installation of this product voids the warranty. Curt Manufacturing Inc.'s liability is limited to repair or replacement of products found to be defective, and specifically excludes liability for incidental or consequential loss or damage.