

11767

93-02 MITSUBISHI MIRAGE, 93-94 DODGE COLT &amp; 93-97 EAGLE SUMMIT

9/23/2020

GROSS LOAD CAPACITY WHEN USED AS A WEIGHT CARRYING HITCH: 2,000 LBS. TRAILER WEIGHT &amp; 200 LBS. TONGUE WEIGHT.

**\*\*\*DO NOT EXCEED VEHICLE MANUFACTURER'S RECOMMENDED TOWING CAPACITY.\*\*\***

WARNING: ALL NON-TRAILER LOADS APPLIED TO THIS PRODUCT MUST BE SUPPORTED BY 18050 STABILIZING STRAPS.

**\*\* FAILURE TO PROPERLY SUPPORT NON-TRAILER LOADS WILL VOID PRODUCT WARRANTY\*\***

HAVING INSTALLATION QUESTIONS? CALL TECHNICAL SUPPORT AT 877-287-8634

Parts List			
ITEM	QTY	PART NUMBER	DESCRIPTION
1	1	10-10444	U-BOLT, 7/16-14 UNC, 1-1/2, N/A, CZ
2	2	30-00186	WASHER, FLAT, 3/8, YZ
3	2	7_16 - 14	NYLOCK HEX NUT
4	2	1/2-13 x 1 1/4	HEX BOLT
5	2	20-00174	NUT, HANDLE, 1/2-13 UNC, GRD8, CZ
6	2	1/2"	LOCK WASHER
7	1	CM-11767-SP	.250" PLATE SPACER

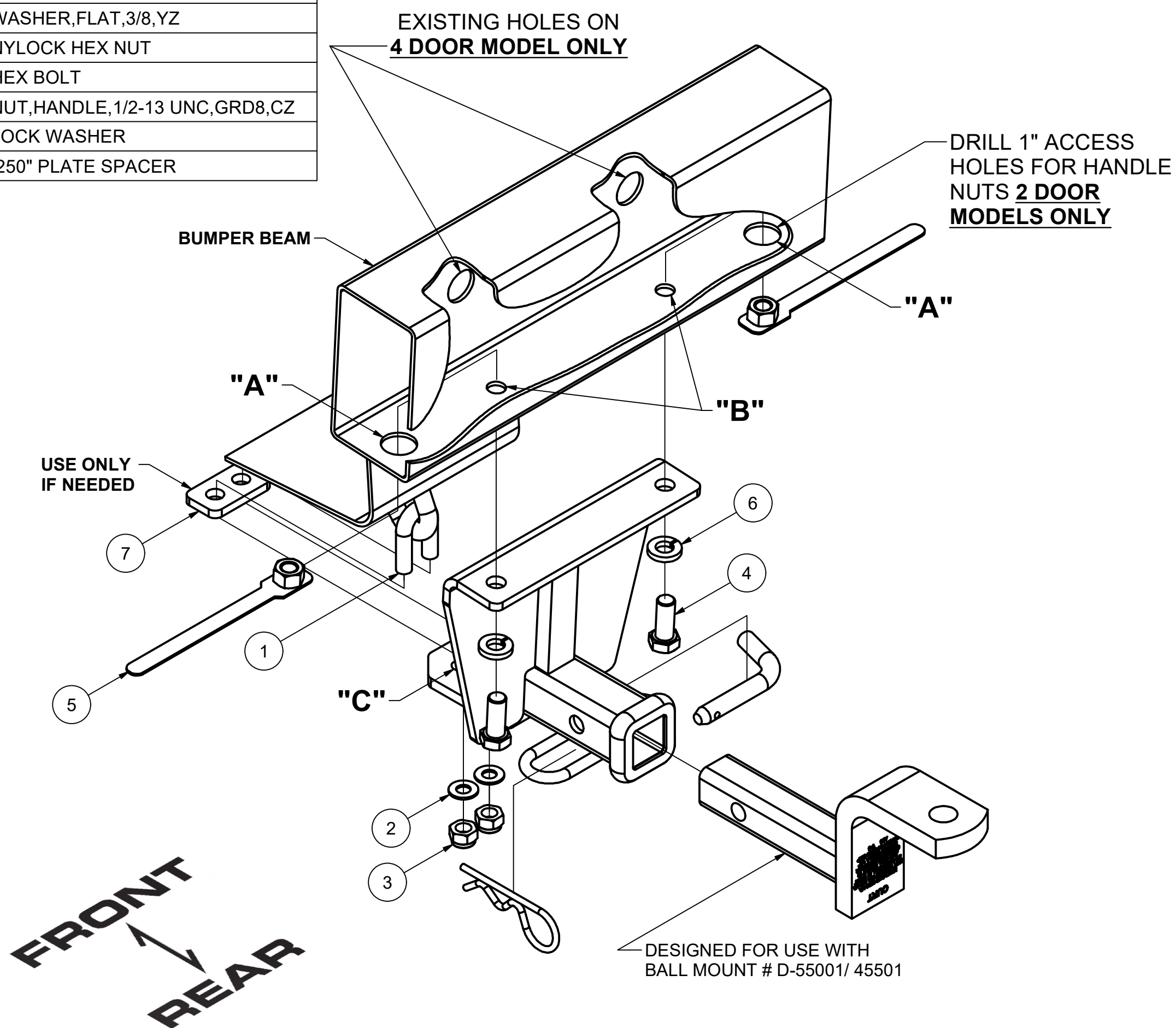

HITCH WEIGHT: 11.25LBS.

INSTALL TIME

PROFESSIONAL: 30 MINUTES

NOVICE (DIY): 60 MINUTES

INSTALL NOTES:

DRILLING REQUIRED  
FACIA TRIMMING MAYBE REQUIREDFRONT  
↑  
REAR**INSTALLATION STEPS**

1. Position hitch under the rear bumper and align tow hook between the holes at "C"
2. Using the hitch as a template mark and drill the holes at "B" (If you have a 2 door model then you must drill two 1" holes at "A" approximately 3.5" to the outside of the holes at "B". see diagram)
3. Insert the handle nuts through either the existing holes (4 door) or 1" drilled holes (2 door) and position over holes in the bumper. Place the 1/2" lock washers onto the 1/2" bolts as shown. Place bolts up through the holes in the hitch and bumper at "B" and thread into handle nuts. **DO NOT TIGHTEN AT THIS TIME.**
4. Hook 7/16" U-bolt through tow loop and insert into holes at "C". Place flat washer and lock nut onto each side and finger tighten evenly. (\*NOTE\* A 1/4" thick spacer has been included to be use to level the hitch if needed.)
5. Tighten 7/16" U-bolt to 25 ft-lbs and 1/2" fasteners to 110 ft-lbs.  
**DO NOT USE IMPACT WRENCH ON U-BOLT!!**

**PERIODICALLY CHECK THIS RECEIVER HITCH TO ENSURE THAT ALL FASTENERS ARE TIGHT AND THAT ALL STRUCTURAL COMPONENTS ARE SOUND.**

Curt Manufacturing Inc., warrants this product to be free of defects in material and/or workmanship at the time of retail purchase by the original purchaser. If the product is found to be defective, Curt Manufacturing Inc., may repair or replace the product, at their option, when the product is returned, prepaid, with proof of purchase. Alteration to, misuse of, or improper installation of this product voids the warranty. Curt Manufacturing Inc.'s liability is limited to repair or replacement of products found to be defective, and specifically excludes liability for incidental or consequential loss or damage.