

11751

98-04 MERCEDES SLK CONVERTIBLE

12/5/2012

GROSS LOAD CAPACITY WHEN USED AS A WEIGHT CARRYING HITCH: 2,000 LBS. TRAILER WEIGHT & 200 LBS. TONGUE WEIGHT.

DO NOT EXCEED VEHICLE MANUFACTURER'S RECOMMENDED TOWING CAPACITY.

WARNING: ALL NON-TRAILER LOADS APPLIED TO THIS PRODUCT MUST BE SUPPORTED BY 18050 STABILIZING STRAPS.

** FAILURE TO PROPERLY SUPPORT NON-TRAILER LOADS WILL VOID PRODUCT WARRANTY**

HAVING INSTALLATION QUESTIONS? CALL TECHNICAL SUPPORT AT 1-800-798-0813

Parts List			
ITEM	QTY	PART NUMBER	DESCRIPTION
1	4	7/16-14	HEX FLANGE NUT
2	2	CM-SP40	.188 x 1.00 x 3.00" SQUARE HOLE SPACER
3	2	7/16-14 x 1 1/2	HEX BOLT
4	2	7/16 LOCK WASHER	HELICAL LOCK WASHER
5	4	7/16-14 x 1 1/2	CARRIAGE BOLT
6	2	7_16-14 TAB NUT	HANDLE NUT
7	1	CM-11751-BP	.250 BACKING PLATE

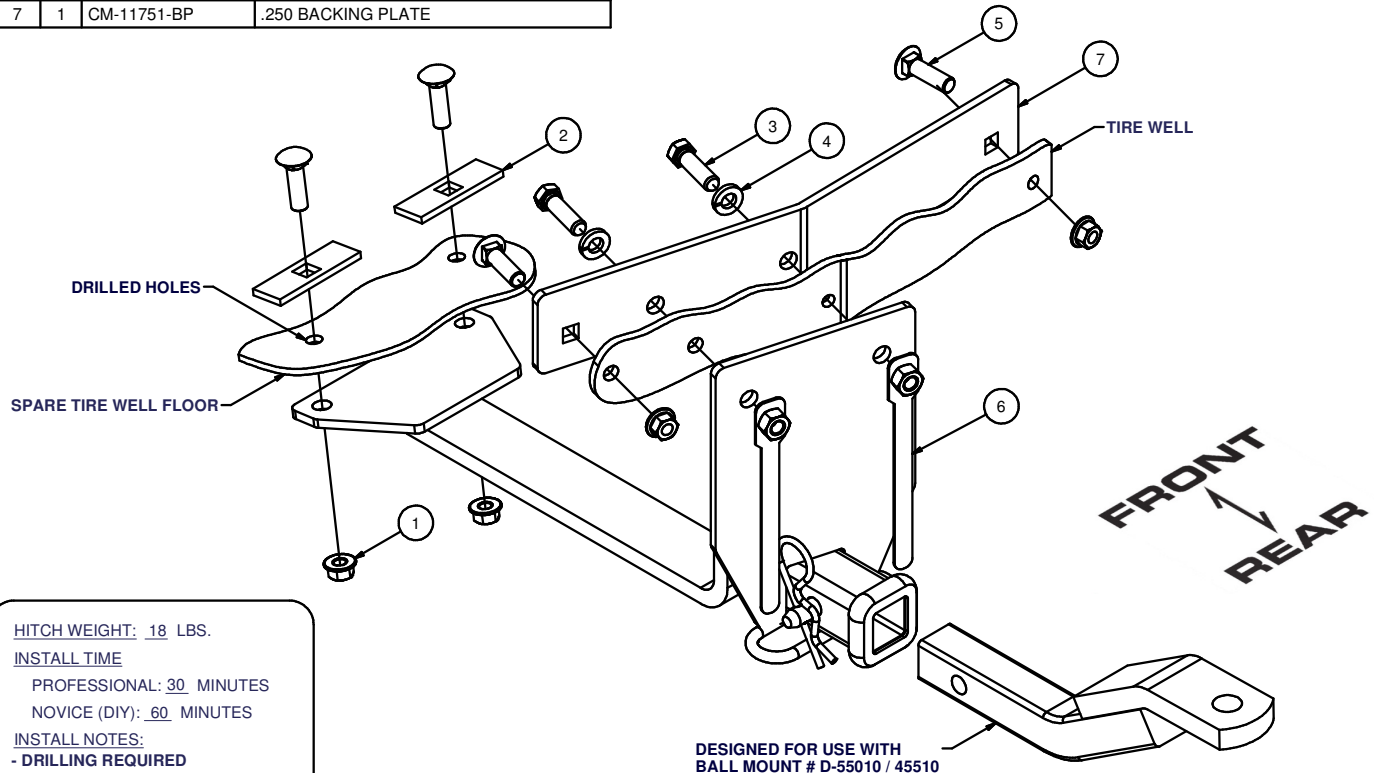

HITCH WEIGHT: 18 LBS.

INSTALL TIME

PROFESSIONAL: 30 MINUTES

NOVICE (DIY): 60 MINUTES

INSTALL NOTES:

- DRILLING REQUIRED
- REMOVE SPARE TIRE
- SILICONE SEAL DRILLED HOLES

INSTALLATION STEPS

1. Temporarily remove contents from spare tire well. Place backing plate inside trunk against rear of tire well with punched holes closer to bottom. Make sure that center point between the two round holes are on center line of vehicle and position the top of the plate against lip just below top of tire well.
2. Mark and center punch the centers of the backing plate holes on spare tire well. Drill holes and install hardware through backing plate and hitch as shown.
3. Using the hitch as a template, drill remaining mounting holes through spare tire well and install fasteners as shown.
4. Torque all 7/16" hardware to 70 lb.-ft.
5. Use silicone sealant to seal around hardware in the spare tire well.
6. Reinstall contents removed in Step 1.

PERIODICALLY CHECK THIS RECEIVER HITCH TO ENSURE THAT ALL FASTENERS ARE TIGHT AND THAT ALL STRUCTURAL COMPONENTS ARE SOUND.

Curt Manufacturing Inc., warrants this product to be free of defects in material and/or workmanship at the time of retail purchase by the original purchaser. If the product is found to be defective, Curt Manufacturing Inc., may repair or replace the product, at their option, when the product is returned, prepaid, with proof of purchase. Alteration to, misuse of, or improper installation of this product voids the warranty. Curt Manufacturing Inc.'s liability is limited to repair or replacement of products found to be defective, and specifically excludes liability for incidental or consequential loss or damage.