

11750 97-00 JAGUAR XK8 COUPE & XKR (INCL. CONVERTIBLE)

12/7/2012

GROSS LOAD CAPACITY WHEN USED AS A WEIGHT CARRYING HITCH: 2,000 LBS. TRAILER WEIGHT & 200 LBS. TONGUE WEIGHT.

*****DO NOT EXCEED VEHICLE MANUFACTURER'S RECOMMENDED TOWING CAPACITY.*****

WARNING: ALL NON-TRAILER LOADS APPLIED TO THIS PRODUCT MUST BE SUPPORTED BY 18050 STABILIZING STRAPS.

**** FAILURE TO PROPERLY SUPPORT NON-TRAILER LOADS WILL VOID PRODUCT WARRANTY****

HAVING INSTALLATION QUESTIONS? CALL TECHNICAL SUPPORT AT 1-877-287-8634

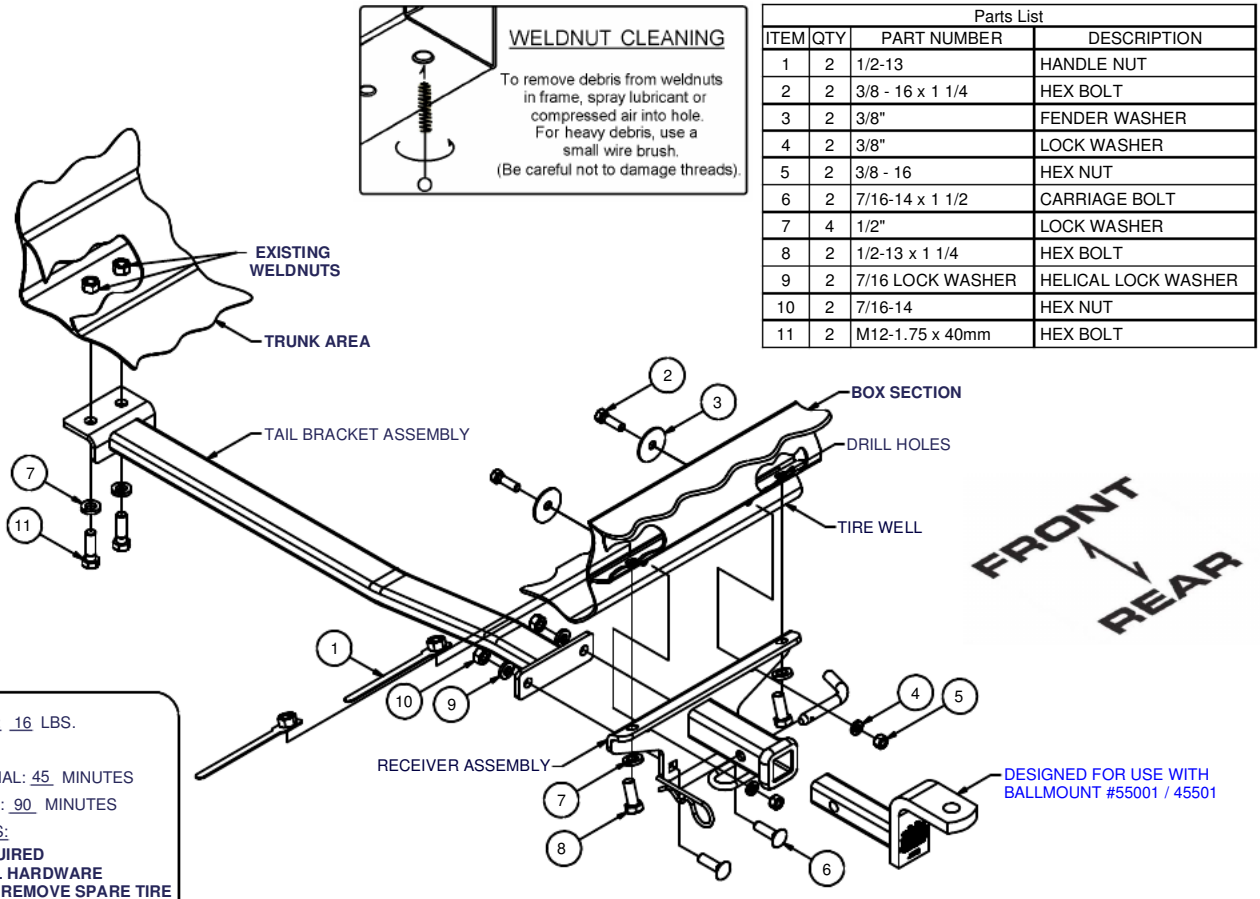

INSTALLATION STEPS

1. This hitch mounts to the rear body panel behind the bumper and to the bottom of the spare tire well. Temporarily remove the spare tire and any inside plastic dress panels on the rear surface of the trunk area. Assemble the tail bracket assembly to the receiver assembly as shown.
2. Lift the hitch into position; aligning the holes in the tail bracket with existing weld nuts in the front bottom surface of the tire well. Loosely install fasteners as shown.
3. Center the receiver on the car. Using the hitch as a template, drill holes in the box section of the tirewell as shown. Install handle nuts as shown by passing them through the open ends in the box section.
4. Using the hitch as a template, drill the tire well for fasteners. Install fasteners as shown with large fender washers used inside the tire well.
5. Torque all 3/8" fasteners to 45 lb-ft, all 7/16" fasteners to 70 lb-ft, all 1/2" fasteners to 110 lb-ft, and all 12mm fasteners to 79 lb-ft.
6. Use silicone sealant to seal hardware installed through tire well.
7. Reinstall spare tire and plastic dress panels removed in Step 1.

PERIODICALLY CHECK THIS RECEIVER HITCH TO ENSURE THAT ALL FASTENERS ARE TIGHT AND THAT ALL STRUCTURAL COMPONENTS ARE SOUND.

Curt Manufacturing Inc., warrants this product to be free of defects in material and/or workmanship at the time of retail purchase by the original purchaser. If the product is found to be defective, Curt Manufacturing Inc., may repair or replace the product, at their option, when the product is returned, prepaid, with proof of purchase. Alteration to, misuse of, or improper installation of this product voids the warranty. Curt Manufacturing Inc.'s liability is limited to repair or replacement of products found to be defective, and specifically excludes liability for incidental or consequential loss or damage.