

11745

95-98 VOLKSWAGEN GOLF (GTI VR6 ONLY)

12/10/2012

GROSS LOAD CAPACITY WHEN USED AS A WEIGHT CARRYING HITCH: 2,000 LBS. TRAILER WEIGHT & 200 LBS. TONGUE WEIGHT.

*****DO NOT EXCEED VEHICLE MANUFACTURER'S RECOMMENDED TOWING CAPACITY.*****

WARNING: ALL NON-TRAILER LOADS APPLIED TO THIS PRODUCT MUST BE SUPPORTED BY 18050 STABILIZING STRAPS.

**** FAILURE TO PROPERLY SUPPORT NON-TRAILER LOADS WILL VOID PRODUCT WARRANTY****

HAVING INSTALLATION QUESTIONS? CALL TECHNICAL SUPPORT AT 1-800-798-0813

Parts List			
ITEM	QTY	PART NUMBER	DESCRIPTION
1	2	3/8-16 X 1 1/2	HEX BOLT
2	2	CM-SP61	.188 x 2.50 x 1.50" SPACER
3	4	3/8 - 16 x 1 1/4	HEX BOLT
4	6	HFN3816	HEX FLANGE NUT

**RUBBER ISOLATOR
REMOVAL DIAGRAM**

This technique can be used if and Exhaust Hanger Removal Pliers is not available.

Using a 5/8" open end wrench, slide the wrench up to the rubber isolator, cradling the hanger rod as shown. Next place the flat edge of a pry bar between the wrench and the hanger stop or hanger rod. Then simply rotate the pry bar toward the wrench to remove the rubber isolator.

Note: Using a spray lubricant or soapy water on the hanger rod and the rubber isolator helps removal.

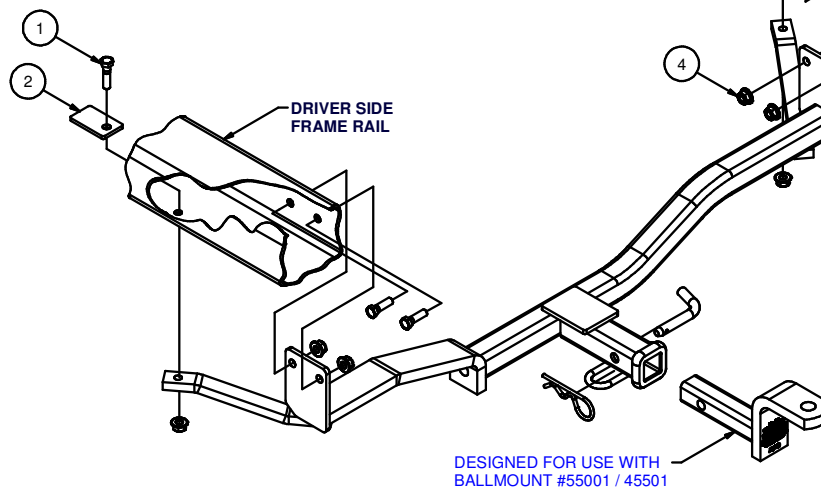
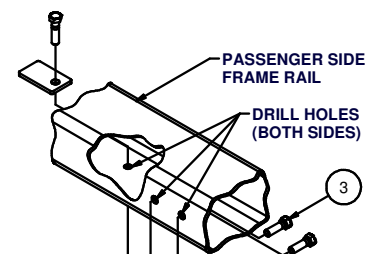
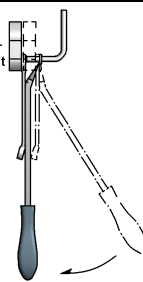

HITCH WEIGHT: 23 LBS.

INSTALL TIME

PROFESSIONAL: 60 MINUTES

NOVICE (DIY): 120 MINUTES

INSTALL NOTES:

- REMOVE BUMPER
- DRILLING REQUIRED
- LOWER EXHAUST

INSTALLATION STEPS

1. Remove the vehicle's rear bumper. There are (7) screws holding the fascia in place; (4) along the top, under plastic covers and (3) along the bottom. The fascia will then unsnap from the tire wells and slide rearward. The bumper beam is removed by removing (4) 13mm nuts attaching the bumper to the frame rails. This exposes a cavity in the body for wrench access.
2. Disconnect the muffler from the hanger by sliding the rubber hanger off of the post.
3. Remove the heavy undercoating from the frame surface where plates will contact the vehicle.
4. Lift the hitch into position under the vehicle as shown. The hitch should be as far rearward as possible against the metal lip. With the hitch in position and level, mark for holes through bolt plates. Remove the hitch and drill the vehicle for 3/8" diameter bolts.
5. Shorten the muffler post 1/4" to 1/2" at this time for clearance if necessary.
6. Reinstall hitch and loosely install fasteners through bolts plates.
7. Using the hitch as a template, drill (2) holes for 3/8" fasteners through bolt arms. Install remaining fasteners as shown.
8. Torque all 3/8" fasteners to 45 lb-ft. Reinstall the bumper beam, bumper fascia, and reinstall exhaust.

PERIODICALLY CHECK THIS RECEIVER HITCH TO ENSURE THAT ALL FASTENERS ARE TIGHT AND THAT ALL STRUCTURAL COMPONENTS ARE SOUND.

Curt Manufacturing Inc., warrants this product to be free of defects in material and/or workmanship at the time of retail purchase by the original purchaser. If the product is found to be defective, Curt Manufacturing Inc., may repair or replace the product, at their option, when the product is returned, prepaid, with proof of purchase. Alteration to, misuse of, or improper installation of this product voids the warranty. Curt Manufacturing Inc.'s liability is limited to repair or replacement of products found to be defective, and specifically excludes liability for incidental or consequential loss or damage.