

11725

90-91 HONDA PRELUDE

12/17/2012

GROSS LOAD CAPACITY WHEN USED AS A WEIGHT CARRYING HITCH: 2,000 LBS. TRAILER WEIGHT & 200 LBS. TONGUE WEIGHT.

\*\*\*DO NOT EXCEED VEHICLE MANUFACTURER'S RECOMMENDED TOWING CAPACITY.\*\*\*

WARNING: ALL NON-TRAILER LOADS APPLIED TO THIS PRODUCT MUST BE SUPPORTED BY 18050 STABILIZING STRAPS.

\*\* FAILURE TO PROPERLY SUPPORT NON-TRAILER LOADS WILL VOID PRODUCT WARRANTY\*\*

HAVING INSTALLATION QUESTIONS? CALL TECHNICAL SUPPORT AT 1-877-287-8634

| Parts List |     |                     |                                       |
|------------|-----|---------------------|---------------------------------------|
| ITEM       | QTY | PART NUMBER         | DESCRIPTION                           |
| 1          | 4   | 7/16"               | CONICAL TOOTHED WASHER                |
| 2          | 4   | M10 - 1.25 x 40 HEX | HEX BOLT                              |
| 3          | 2   | 7/16 LOCK WASHER    | HELICAL LOCK WASHER                   |
| 4          | 2   | 7/16-14             | HEX NUT                               |
| 5          | 2   | 7/16-14 x 1 1/2     | CARRIAGE BOLT                         |
| 6          | 2   | CM-SP2              | .250 x .88 x 2.25" SQUARE HOLE SPACER |
| 7          | 1   | CM-438-FW           | 7/16" FISHWIRE TOOL                   |

**FISHWIRE TECHNIQUE**

INSERT COILED END OF FISHWIRE TOOL THROUGH HITCH MOUNTING HOLE IN VEHICLE FRAME RAIL AND OUT THE ACCESS HOLE. PASS COILED END OF FISHWIRE THROUGH SPACER AND THREAD BOLT INTO COIL. KINK WIRE TO KEEP SPACER SEPERATE FROM BOLT AS SHOWN. PULL FISHWIRE, SPACER, AND BOLT THROUGH FRAME AND OUT MOUNTING HOLE. USE FISHWIRE TO GUIDE HITCH DURING MOUNTING AND PREVENT LOSS OF BOLT / SPACER INSIDE FRAME RAIL.

\*\*\*NOTE: SOME VEHICLES MAY FISHWIRE THROUGH END OF FRAME\*\*\*

**WELDNUT CLEANING**

To remove debris from weldnuts in frame, spray lubricant or compressed air into hole. For heavy debris, use a small wire brush. (Be careful not to damage threads).

INSTALL FASTENERS THROUGH EXISTING ACCESS HOLE

EXISTING WELDNUTS (BOTH SIDES)

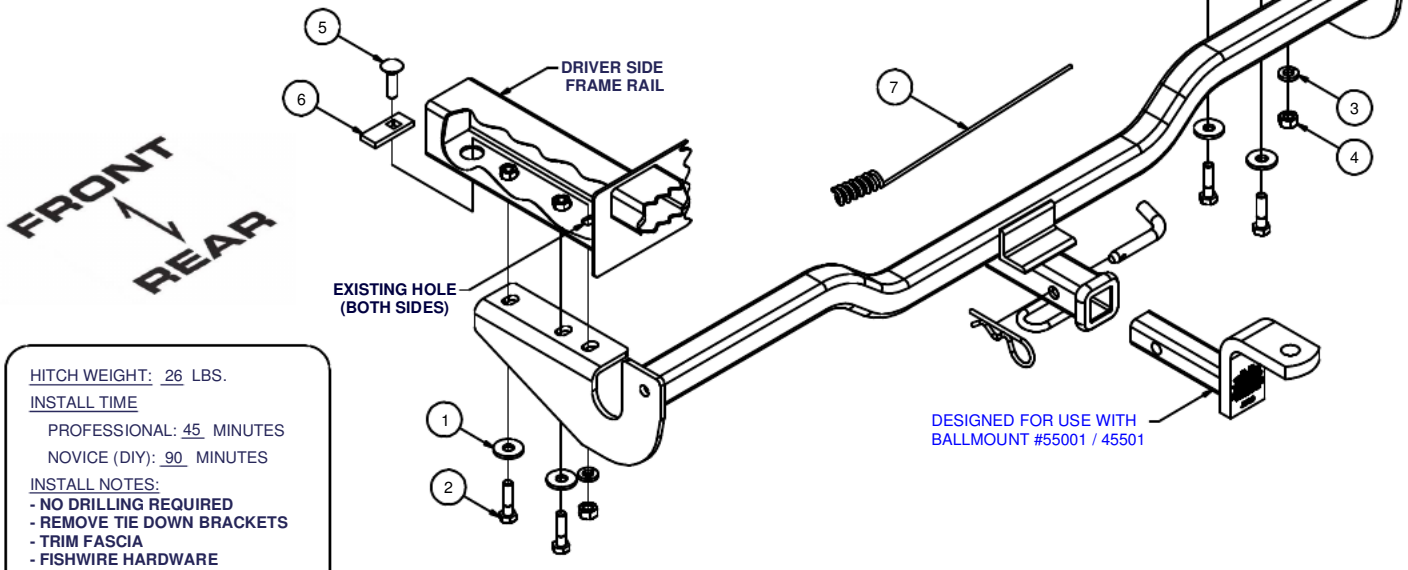

HITCH WEIGHT: 26 LBS.

INSTALL TIME

PROFESSIONAL: 45 MINUTES

NOVICE (DIY): 90 MINUTES

INSTALL NOTES:

- NO DRILLING REQUIRED
- REMOVE TIE DOWN BRACKETS
- TRIM FASCIA
- FISHWIRE HARDWARE

INSTALLATION STEPS

1. Locate the driver and passenger side frame rails under the rear of the vehicle. Remove the tie down brackets from each frame rail ((2) 10mm bolts each). Return all parts to the vehicle owner for reinstallation should the hitch ever be removed.
2. Lift the hitch into position and note location of the fascia interference at the hitch frame plates. Trim fascia until hitch will fit as shown. Lower the hitch.
3. Using the existing access hole in each frame rail, fishwire 7/16" carriage bolts and CM-SP2 spacers into rear hole in each frame rails, as shown.
5. Raise hitch into position and bolt the hitch to the vehicle using fasteners as shown.
6. Torque all 10mm fasteners to 48 lb-ft, and all 7/16" fasteners to 70 lb-ft.

**PERIODICALLY CHECK THIS RECEIVER HITCH TO ENSURE THAT ALL FASTENERS ARE TIGHT AND THAT ALL STRUCTURAL COMPONENTS ARE SOUND.**

Curt Manufacturing Inc., warrants this product to be free of defects in material and/or workmanship at the time of retail purchase by the original purchaser. If the product is found to be defective, Curt Manufacturing Inc., may repair or replace the product, at their option, when the product is returned, prepaid, with proof of purchase. Alteration to, misuse of, or improper installation of this product voids the warranty. Curt Manufacturing Inc.'s liability is limited to repair or replacement of products found to be defective, and specifically excludes liability for incidental or consequential loss or damage.