

11711

1981-1991 MERCEDES BENZ S CLASS

11/24/2020

EXCLUDES AMG SEC

GROSS LOAD CAPACITY WHEN USED AS A WEIGHT CARRYING HITCH: 2,000 LBS. TRAILER WEIGHT & 200 LBS. TONGUE WEIGHT.

DO NOT EXCEED VEHICLE MANUFACTURER'S RECOMMENDED TOWING CAPACITY.

WARNING: ALL NON-TRAILER LOADS APPLIED TO THIS PRODUCT MUST BE SUPPORTED BY AUXILIARY STABILIZING STRAPS.

** FAILURE TO PROPERLY SUPPORT NON-TRAILER LOADS WILL VOID PRODUCT WARRANTY**

HAVING INSTALLATION QUESTIONS? CALL TECHNICAL SUPPORT AT 1-877-287-8634

Parts List			
ITEM	QTY	PART NUMBER	DESCRIPTION
1	2	10-10234	HHCS, 3/8-16 UNC, 1-1/2, GRD8, YZ
2	2	10-10282	BOLT, CAR, 7/16-14 UNC, 1-1/2, GRD8, YZ
3	2	20-00102	NUT, SER-FLANGE, 3/8-16 UNC, GRD8, YZ
4	2	20-00103	NUT, SER-FLANGE, 7/16-14 UNC, GRD8, YZ
5	2	CM-SP108	2.00 X 0.88 X .125 SPACER
6	2	7_16 FISHWIRE	7/16" FISHWIRE

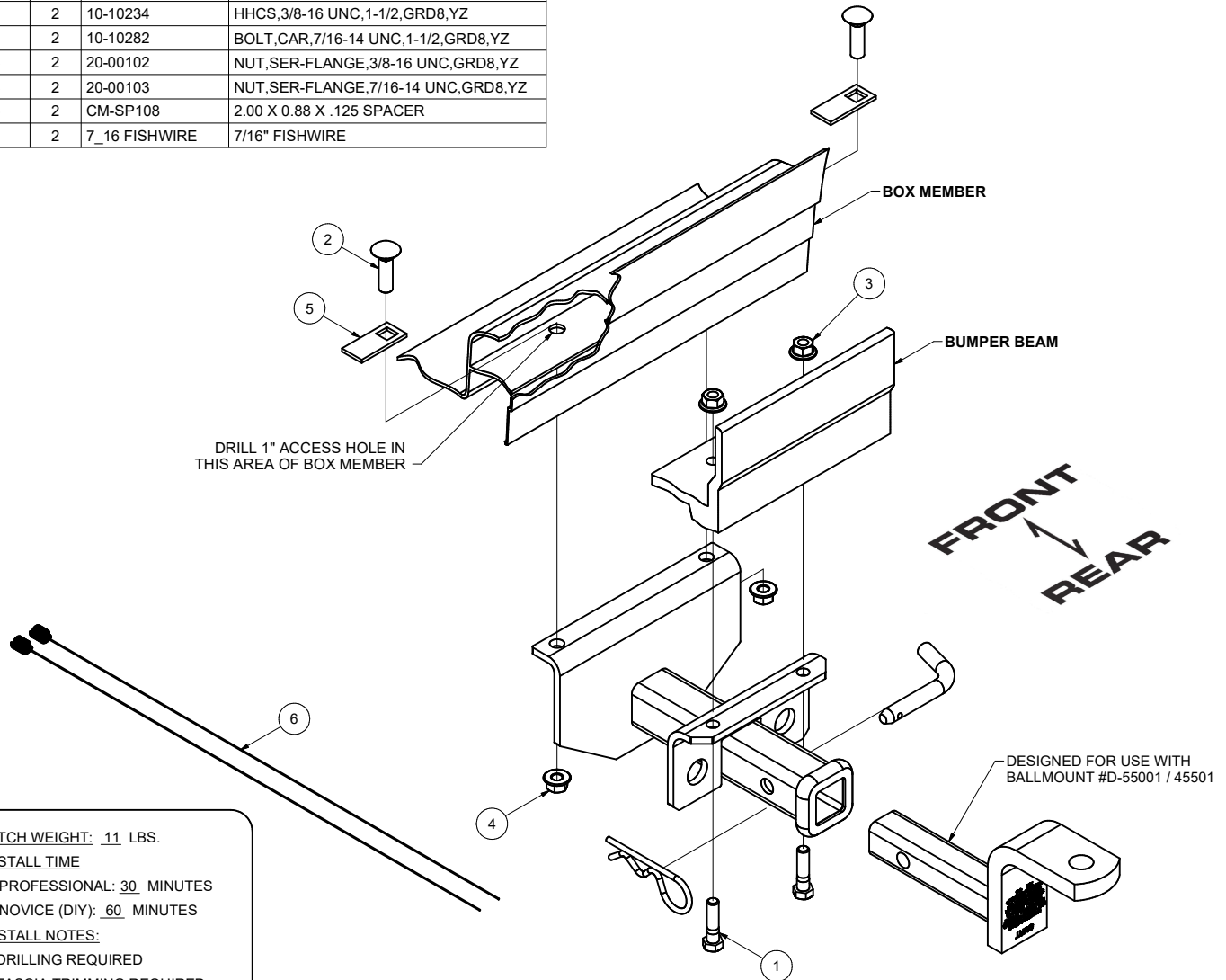

HITCH WEIGHT: 11 LBS.

INSTALL TIME

PROFESSIONAL: 30 MINUTES

NOVICE (DIY): 60 MINUTES

INSTALL NOTES:

- DRILLING REQUIRED
- FASCIA TRIMMING REQUIRED

INSTALLATION STEPS

1. Center and square the hitch on the car bumper beam and box member. Using the hitch as a template mark and drill box member using a 1/2" drill. Mark and drill aluminum bumper beam using a 3/8" drill.
2. Drill a 1" diameter access hole in the bottom surface of the box member for hardware using a hole saw. Position the access hole between the 1/2" mounting holes. Fishwire carriage bolts and spacers through the access hole and out 1/2" holes. Cover access hole with duct tape to seal hole.
3. Carefully position hitch over fasteners and secure with flange nuts. Secure hitch to bumper beam with hex bolts and flange nuts. Bumper fascia can be trimmed for access to bolts.
4. Torque all 7/16" hardware to 70 lb.-ft. and all 3/8" hardware to 45 lb.-ft.

PERIODICALLY CHECK THIS RECEIVER HITCH TO ENSURE THAT ALL FASTENERS ARE TIGHT AND THAT ALL STRUCTURAL COMPONENTS ARE SOUND.

Curt Manufacturing Inc., warrants this product to be free of defects in material and/or workmanship at the time of retail purchase by the original purchaser. If the product is found to be defective, Curt Manufacturing Inc., may repair or replace the product, at their option, when the product is returned, prepaid, with proof of purchase. Alteration to, misuse of, or improper installation of this product voids the warranty. Curt Manufacturing Inc.'s liability is limited to repair or replacement of products found to be defective, and specifically excludes liability for incidental or consequential loss or damage.