

11706

90-92 INFINITI M30

12/14/2012

GROSS LOAD CAPACITY WHEN USED AS A WEIGHT CARRYING HITCH: 2,000 LBS. TRAILER WEIGHT & 200 LBS. TONGUE WEIGHT.

DO NOT EXCEED VEHICLE MANUFACTURER'S RECOMMENDED TOWING CAPACITY.

WARNING: ALL NON-TRAILER LOADS APPLIED TO THIS PRODUCT MUST BE SUPPORTED BY 18050 STABILIZING STRAPS.

** FAILURE TO PROPERLY SUPPORT NON-TRAILER LOADS WILL VOID PRODUCT WARRANTY**

HAVING INSTALLATION QUESTIONS? CALL TECHNICAL SUPPORT AT 1-877-287-8634

Parts List			
ITEM	QTY	PART NUMBER	DESCRIPTION
1	5	M10-1.25 x 35	HEX BOLT
2	5	7/16"	CONICAL TOOTHED WASHER

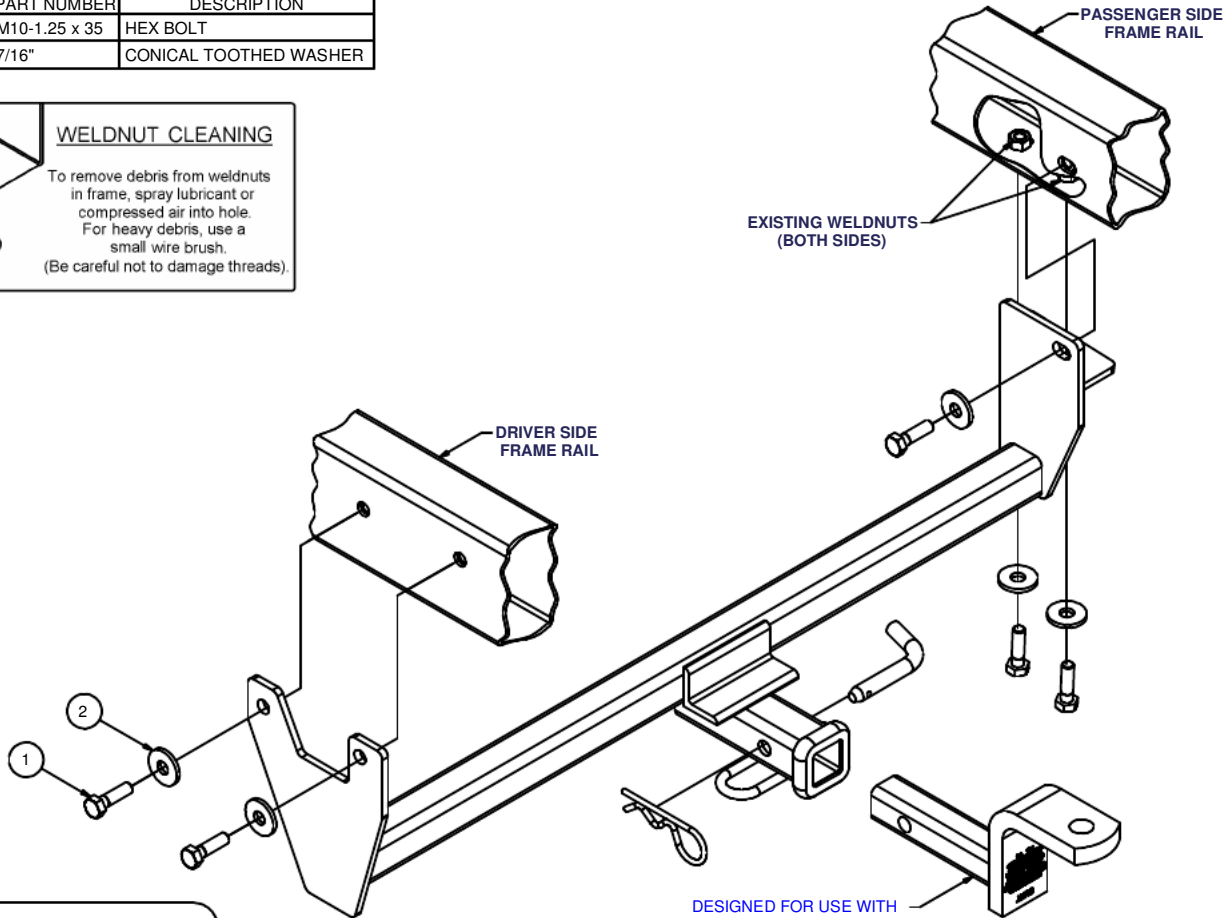
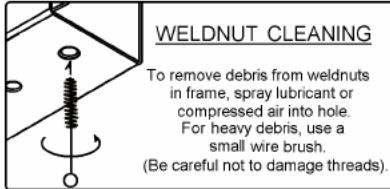

HITCH WEIGHT: 19 LBS.

INSTALL TIME

PROFESSIONAL: 30 MINUTES

NOVICE (DIY): 60 MINUTES

INSTALL NOTES:

- NO DRILLING REQUIRED
- REMOVE EXISTING BOLTS
- TRIM HEAT SHIELD
- RELOCATE EXHAUST HANGER

INSTALLATION STEPS

1. Under the rear of the vehicle, locate the driver and passenger side frame rails. Note the (2) hex cap bolts in the driver side frame rail. Also note the (2) cap bolts in the bottom of the passenger side frame rail and (1) on the inside of the frame rail. Remove the (3) bolts from the passenger side frame rail and (2) bolts from the driver side frame rail. The exhaust hanger on the driver side will now be loose from the frame. Trim heat shield if necessary.
2. This hitch will mount to the frame rails at the existing weldnuts where the bolts were removed. Lift the hitch into position. Secure hitch using hardware as shown. Use cup side of conical toothed washers facing the hitch. Remount the exhaust hanger to the outside of the hitch plate under bolts at the same location.
3. Torque all 10mm fasteners to 48 lb-ft.

PERIODICALLY CHECK THIS RECEIVER HITCH TO ENSURE THAT ALL FASTENERS ARE TIGHT AND THAT ALL STRUCTURAL COMPONENTS ARE SOUND.

Curt Manufacturing Inc., warrants this product to be free of defects in material and/or workmanship at the time of retail purchase by the original purchaser. If the product is found to be defective, Curt Manufacturing Inc., may repair or replace the product, at their option, when the product is returned, prepaid, with proof of purchase. Alteration to, misuse of, or improper installation of this product voids the warranty. Curt Manufacturing Inc.'s liability is limited to repair or replacement of products found to be defective, and specifically excludes liability for incidental or consequential loss or damage.