

11662**87-93 VOLKSWAGEN FOX**

12/14/2012

GROSS LOAD CAPACITY WHEN USED AS A WEIGHT CARRYING HITCH: 1,000 LBS. TRAILER WEIGHT & 100 LBS. TONGUE WEIGHT.

*****DO NOT EXCEED VEHICLE MANUFACTURER'S RECOMMENDED TOWING CAPACITY.*****

WARNING: ALL NON-TRAILER LOADS APPLIED TO THIS PRODUCT MUST BE SUPPORTED BY 18050 STABILIZING STRAPS.

**** FAILURE TO PROPERLY SUPPORT NON-TRAILER LOADS WILL VOID PRODUCT WARRANTY****

HAVING INSTALLATION QUESTIONS? CALL TECHNICAL SUPPORT AT 1-877-287-8634

Parts List			
ITEM	QTY	PART NUMBER	DESCRIPTION
1	2	3/8-16 X 1 1/2	HEX BOLT
2	5	HFN3816	HEX FLANGE NUT
3	3	3/8 - 16 x 1 1/4	HEX BOLT
4	3	3/8"	FENDER WASHER

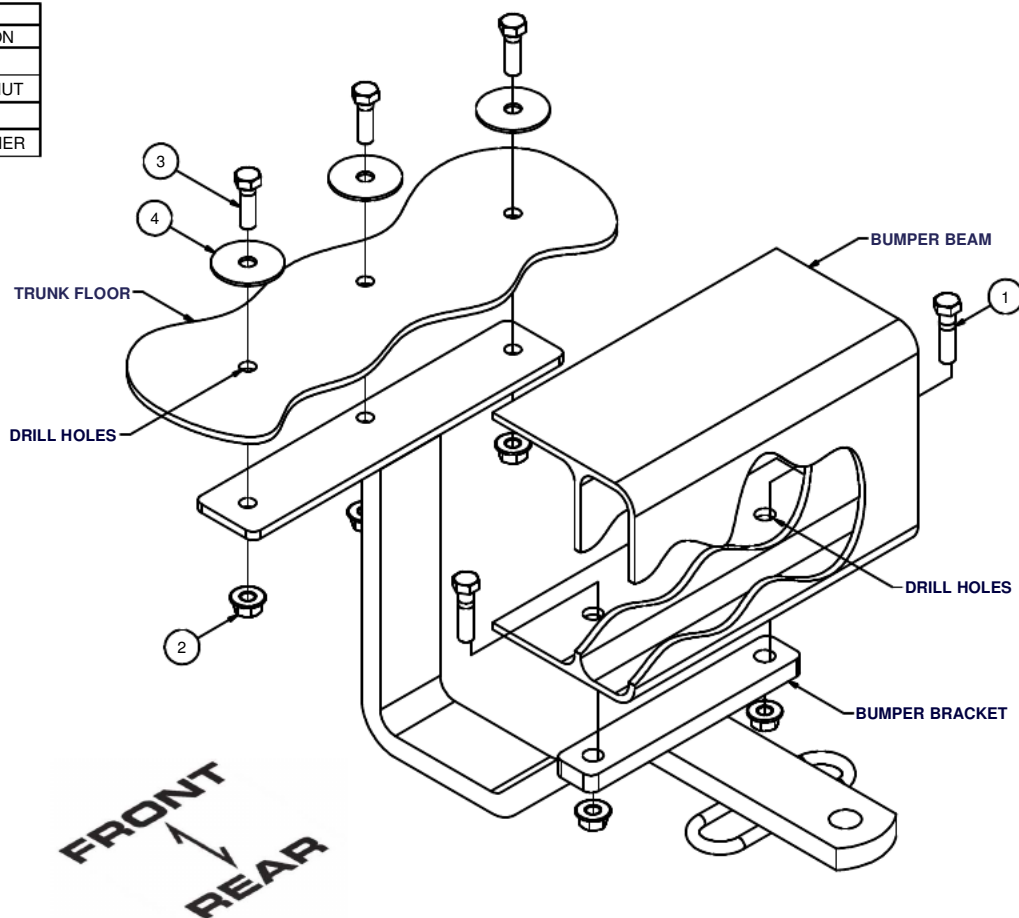

HITCH WEIGHT: 12 LBS.

INSTALL TIME

PROFESSIONAL: 30 MINUTES

NOVICE (DIY): 60 MINUTES

INSTALL NOTES:

- CLEAR TRUNK OF CONTENTS
- DRILLING REQUIRED
- FASCIA TRIMMING REQUIRED
- SILICONE HARDWARE

INSTALLATION STEPS

1. Clear the vehicle's trunk as necessary for drilling. Mark the vehicle's centerline on the rear bumper. The bumper bracket of the hitch must fit directly against the bumper's inner steel bumper. Mark the bumper fascia (plastic) where the bracket must fit through and trim as required. With hitch positioned against inner bumper and trunk, centered and square with the vehicle, mark (2) holes at bumper and (3) at the trunk floor as shown.
2. Centerpunch and drill (5) holes for 3/8" bolts. Make sure to drill holes so bolts position in bumper as shown in diagram.
3. Fasten hitch to vehicle using fasteners as shown. Note that bolts are placed on the inside surface of the bumper. These can be placed by hand, by temporarily removing plastic retainers at fascia under the vehicle, and pulling fascia away enough to reach the bolts. Fender washers must also be placed inside the trunk, opposite the hitch.
4. Torque all 3/8" fasteners to 45 lb-ft.
5. Use silicone sealant around fasteners in trunk to seal out exhaust fumes and water.
6. Reinstall trunk contents removed in step 1.

PERIODICALLY CHECK THIS RECEIVER HITCH TO ENSURE THAT ALL FASTENERS ARE TIGHT AND THAT ALL STRUCTURAL COMPONENTS ARE SOUND.

Curt Manufacturing Inc., warrants this product to be free of defects in material and/or workmanship at the time of retail purchase by the original purchaser. If the product is found to be defective, Curt Manufacturing Inc., may repair or replace the product, at their option, when the product is returned, prepaid, with proof of purchase. Alteration to, misuse of, or improper installation of this product voids the warranty. Curt Manufacturing Inc.'s liability is limited to repair or replacement of products found to be defective, and specifically excludes liability for incidental or consequential loss or damage.