

11588

## 84-87 HONDA CIVIC HATCHBACK (EXCEPT CRX)

12/10/2012

GROSS LOAD CAPACITY WHEN USED AS A WEIGHT CARRYING HITCH: 1,000 LBS. TRAILER WEIGHT &amp; 100 LBS. TONGUE WEIGHT.

**\*\*\*DO NOT EXCEED VEHICLE MANUFACTURER'S RECOMMENDED TOWING CAPACITY.\*\*\***

WARNING: ALL NON-TRAILER LOADS APPLIED TO THIS PRODUCT MUST BE SUPPORTED BY 18050 STABILIZING STRAPS.

**\*\* FAILURE TO PROPERLY SUPPORT NON-TRAILER LOADS WILL VOID PRODUCT WARRANTY\*\***

HAVING INSTALLATION QUESTIONS? CALL TECHNICAL SUPPORT AT 1-877-287-8634

Parts List			
ITEM	QTY	PART NUMBER	DESCRIPTION
1	5	3/8"	LOCK WASHER
2	5	3/8 - 16	HEX NUT
3	2	3/8 - 16 x 1 1/4	HEX BOLT
4	2	3/8"	FENDER WASHER
5	2	3/8 - 16 x 4	HEX BOLT
6	4	3/8"	WASHER
7	1	3/8 - 16 x 1 3/4	HEX BOLT
8	1	CM-11588-TB	.375 x 1.50 TAIL BRACKET

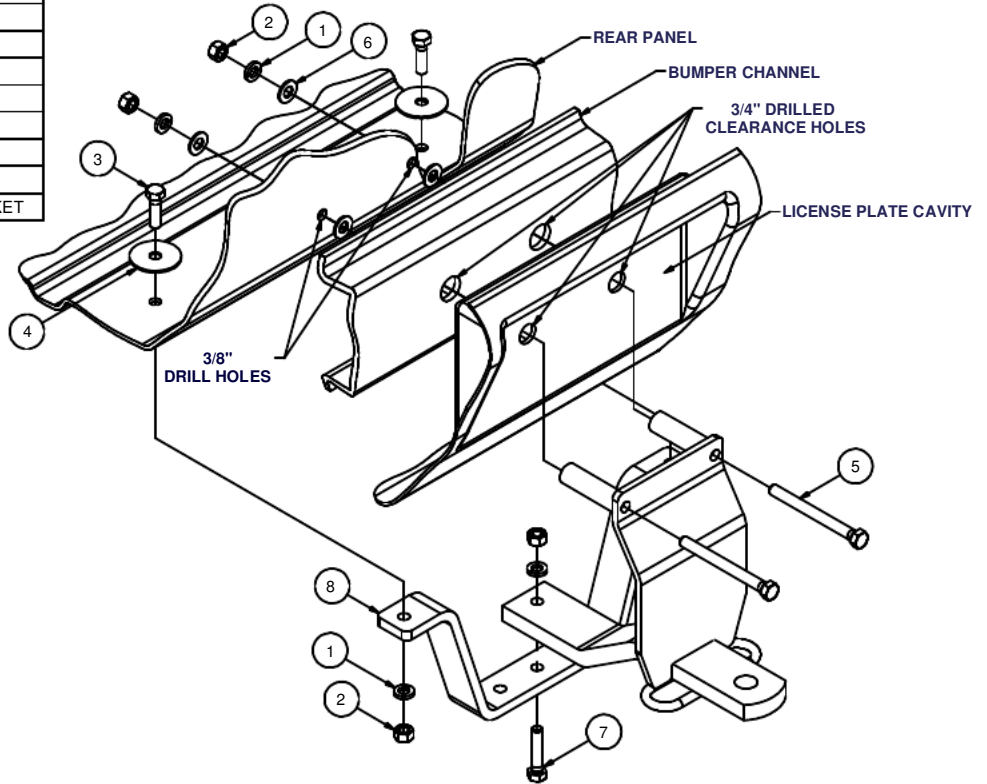

FRONT  
↑  
REAR

HITCH WEIGHT: 11 LBS.

INSTALL TIME

PROFESSIONAL: 45 MINUTES

NOVICE (DIY): 90 MINUTES

INSTALL NOTES:

- DRILLING REQUIRED
- TEMPORARILY REMOVE LICENSE PLATE
- TEMPORARILY REMOVE SPARE TIRE
- SILICONE SEAL AROUND FASTENERS

**INSTALLATION STEPS**

1. Remove the license plate, and clear the trunk area. Locate and mark the car's centerline on the rear bumper channel.
2. Assemble the hitch tail bracket to tongue through the center hole using fasteners shown. Hold the hitch centered and level against the car so that the spacer tubes (see diagram) rest against the bumper channel. Mark the license plate cavity and bumper channel for two 3/4" clearance holes for spacer tubes. Drill the bumper channel and plate cavity for spacer tubes.

NOTE: Clearance holes may not fall centered on the channel.

3. Position the hitch on the car with spacer tubes passing through the license plate cavity and bumper channel. Drill the rear panel for two 3/8" diameter holes by drilling directly through the spacer tube. Use fasteners as shown and bolt the hitch to the rear panel making sure to use flat washers on BOTH sides of panel.
4. Drill the trunk floor two places through hitch tail bracket for 3/8" bolts. Fasten the hitch to the floor. Make sure fender washers are installed INSIDE the vehicle, opposite the hitch.
5. Torque all 3/8" fasteners to 45 lb-ft.
6. Use silicone sealant to seal hardware installed in trunk.
7. Reinstall spare tire and license plate.

**PERIODICALLY CHECK THIS RECEIVER HITCH TO ENSURE THAT ALL FASTENERS ARE TIGHT AND THAT ALL STRUCTURAL COMPONENTS ARE SOUND.**

Curt Manufacturing Inc., warrants this product to be free of defects in material and/or workmanship at the time of retail purchase by the original purchaser. If the product is found to be defective, Curt Manufacturing Inc., may repair or replace the product, at their option, when the product is returned, prepaid, with proof of purchase. Alteration to, misuse of, or improper installation of this product voids the warranty. Curt Manufacturing Inc.'s liability is limited to repair or replacement of products found to be defective, and specifically excludes liability for incidental or consequential loss or damage.