

11570

84-87 PONTIAC FIERO COUPE

12/14/2012

GROSS LOAD CAPACITY WHEN USED AS A WEIGHT CARRYING HITCH: 1,000 LBS. TRAILER WEIGHT & 100 LBS. TONGUE WEIGHT.

DO NOT EXCEED VEHICLE MANUFACTURER'S RECOMMENDED TOWING CAPACITY.

WARNING: ALL NON-TRAILER LOADS APPLIED TO THIS PRODUCT MUST BE SUPPORTED BY 18050 STABILIZING STRAPS.

** FAILURE TO PROPERLY SUPPORT NON-TRAILER LOADS WILL VOID PRODUCT WARRANTY**

HAVING INSTALLATION QUESTIONS? CALL TECHNICAL SUPPORT AT 1-877-287-8634

Parts List			
ITEM	QTY	PART NUMBER	DESCRIPTION
1	2	1_2 FISHWIRE	1/2" FISHWIRE
2	4	1/2-13	HEX NUT
3	4	1/2"	LOCK WASHER
4	4	FW12	FW, 12, ZP
5	4	1/2-13 x 1 3/4	CARRIAGE BOLT
6	2	CM-SP40	.188 x 1.00 x 3.00" SQUARE HOLE SPACER
7	2	CM-SP33	.250 x 1.50 x 2.00" SQUARE HOLE SPACER

FISHWIRE TECHNIQUE

INSERT COILED END OF FISHWIRE TOOL THROUGH HITCH MOUNTING HOLE IN VEHICLE FRAME RAIL AND OUT THE ACCESS HOLE. PASS COILED END OF FISHWIRE THROUGH SPACER AND THREAD BOLT INTO COIL. KINK WIRE TO KEEP SPACER SEPARATE FROM BOLT AS SHOWN. PULL FISHWIRE, SPACER, AND BOLT THROUGH FRAME AND OUT MOUNTING HOLE. USE FISHWIRE TO GUIDE HITCH DURING MOUNTING AND PREVENT LOSS OF BOLT / SPACER INSIDE FRAME RAIL.

NOTE: SOME VEHICLES MAY FISHWIRE THROUGH END OF FRAME

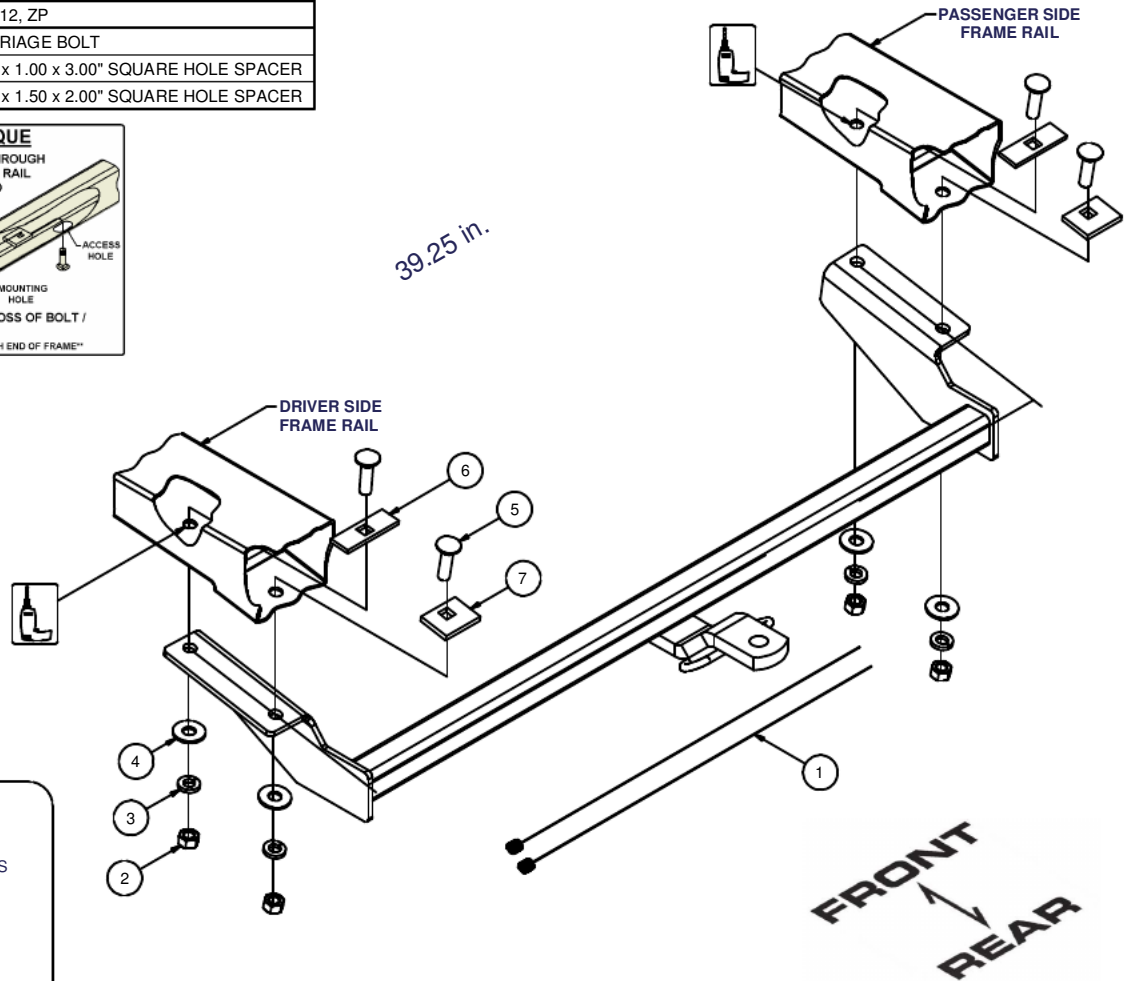
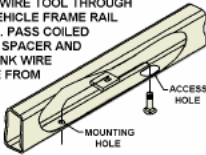

HITCH WEIGHT: 19 LBS.

INSTALL TIME

PROFESSIONAL: 45 MINUTES

NOVICE (DIY): 90 MINUTES

INSTALL NOTES:

- DRILLING REQUIRED
- FISHWIRE HARDWARE

INSTALLATION STEPS

1. Fishwire the CM-SP33 spacers and 1/2" carriage bolt into the vehicle's frame rails through existing rear slots. Use access hole in the end of the vehicle frame rails. Position the hitch on the car over the 1/2" bolts and install the washers and nuts without fully tightening them.
2. Center the hitch on the vehicle and position front to rear for best fit. Note that the front holes fall on a step area at the rear of the frame. With the hitch secured to the vehicle, use the hitch as a template and drill front set of holes for 1/2" diameter fasteners.
3. Fishwire the CM-SP40 spacers and 1/2" carriage bolt into these drilled holes using access holes at the end of the frame. Install remaining fasteners as shown.
4. Torque all 1/2" fasteners to 110 lb-ft.

PERIODICALLY CHECK THIS RECEIVER HITCH TO ENSURE THAT ALL FASTENERS ARE TIGHT AND THAT ALL STRUCTURAL COMPONENTS ARE SOUND.

Curt Manufacturing Inc., warrants this product to be free of defects in material and/or workmanship at the time of retail purchase by the original purchaser. If the product is found to be defective, Curt Manufacturing Inc., may repair or replace the product, at their option, when the product is returned, prepaid, with proof of purchase. Alteration to, misuse of, or improper installation of this product voids the warranty. Curt Manufacturing Inc.'s liability is limited to repair or replacement of products found to be defective, and specifically excludes liability for incidental or consequential loss or damage.