

11552**87-90 NISSAN SENTRA (SEDAN ONLY)**

12/10/2012

GROSS LOAD CAPACITY WHEN USED AS A WEIGHT CARRYING HITCH: 1,000 LBS. TRAILER WEIGHT & 100 LBS. TONGUE WEIGHT.

*****DO NOT EXCEED VEHICLE MANUFACTURER'S RECOMMENDED TOWING CAPACITY.*****

WARNING: ALL NON-TRAILER LOADS APPLIED TO THIS PRODUCT MUST BE SUPPORTED BY 18050 STABILIZING STRAPS.

**** FAILURE TO PROPERLY SUPPORT NON-TRAILER LOADS WILL VOID PRODUCT WARRANTY****

HAVING INSTALLATION QUESTIONS? CALL TECHNICAL SUPPORT AT 1-877-287-8634

Parts List				
ITEM	QTY	PART NUMBER	DESCRIPTION	
1	4	3/8 - 16 x 1 1/4	HEX BOLT	
2	4	3/8"	FENDER WASHER	
3	1	7_16 - 14 x 2.00 x 4.75 C-C SQ. U-BOLT	SQ. U-BOLT	
4	4	HFN3816	HEX FLANGE NUT	
5	2	7/16-14	HEX FLANGE NUT	

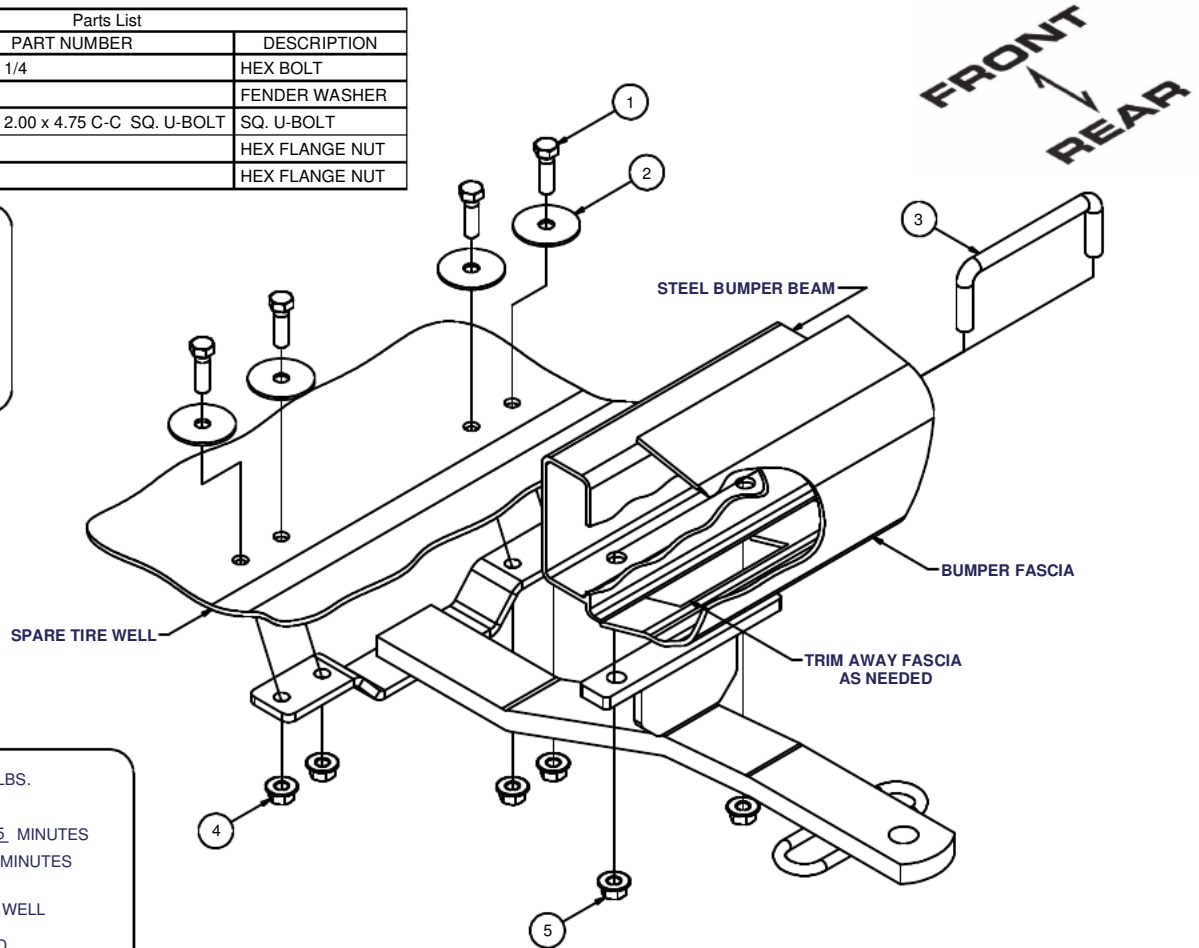
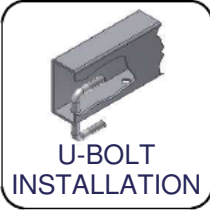

HITCH WEIGHT: 10 LBS.

INSTALL TIME

PROFESSIONAL: 45 MINUTES

NOVICE (DIY): 90 MINUTES

INSTALL NOTES:

- CLEAR SPARE TIRE WELL
- TRIM FASCIA
- DRILLING REQUIRED
- SILICONE SEAL HARDWARE

INSTALLATION STEPS

1. Remove all contents from the spare tire well. Locate and mark the vehicle's centerline so the hitch is centered on the rear bumper.
2. Cut away the vehicle's plastic fascia to clear the hitch bracket at the bumper beam. With the hitch in place as shown, centered and square with the vehicle, mark and center punch the bumper and the trunk floor for holes.
3. Drill (4) holes in spare tire well for 3/8" diameter hardware. Drill (2) holes in bumper beam for 7/16" hardware.
4. Install U-bolt in bumper following the diagram. NOTE: Holes in bumper beam may be worked slightly larger if necessary to get the U-bolt into the bumper. Mount the hitch using fasteners as shown. Fender washers must be installed inside the vehicle, opposite the hitch.
5. Torque all 3/8" fasteners to 45 lb-ft and all 7/16" fasteners to 70 lb-ft.
6. Use silicone sealant to seal hardware installed through spare tire well.
7. Reinstall contents removed from spare tire well in Step 1.

PERIODICALLY CHECK THIS RECEIVER HITCH TO ENSURE THAT ALL FASTENERS ARE TIGHT AND THAT ALL STRUCTURAL COMPONENTS ARE SOUND.

Curt Manufacturing Inc., warrants this product to be free of defects in material and/or workmanship at the time of retail purchase by the original purchaser. If the product is found to be defective, Curt Manufacturing Inc., may repair or replace the product, at their option, when the product is returned, prepaid, with proof of purchase. Alteration to, misuse of, or improper installation of this product voids the warranty. Curt Manufacturing Inc.'s liability is limited to repair or replacement of products found to be defective, and specifically excludes liability for incidental or consequential loss or damage.