

**11440****02-07 SUZUKI AERIO HATCHBACK**

11/12/2012

GROSS LOAD CAPACITY WHEN USED AS A WEIGHT CARRYING HITCH: 1,000 LBS. TRAILER WEIGHT &amp; 100 LBS. TONGUE WEIGHT.

**\*\*\*DO NOT EXCEED VEHICLE MANUFACTURER'S RECOMMENDED TOWING CAPACITY.\*\*\*****WARNING: ALL NON-TRAILER LOADS APPLIED TO THIS PRODUCT MUST BE SUPPORTED BY AUXILIARY STABILIZING STRAPS.****\*\* FAILURE TO PROPERLY SUPPORT NON-TRAILER LOADS WILL VOID PRODUCT WARRANTY\*\***

HAVING INSTALLATION QUESTIONS? CALL TECHNICAL SUPPORT AT 1-877-287-8634

Parts List			
ITEM	QTY	PART NUMBER	DESCRIPTION
1	2	7/16-14 x 2 1/2	CARRIAGE BOLT
2	2	7/16-14	LARGE HEX FLANGE NUT
3	2	1/2-13 x 3	HEX BOLT
4	2	CM-SP4	.250 x 1.50 x 3.00" SQUARE HOLE SPACER
5	2	HFN 1213	HEX FLANGE NUT
6	2	CM-SP2	.250 x .88 x 2.25" SQUARE HOLE SPACER
7	2	CM-SP31	.250 x 1.75 x 2.00" U-SHAPE SPACER

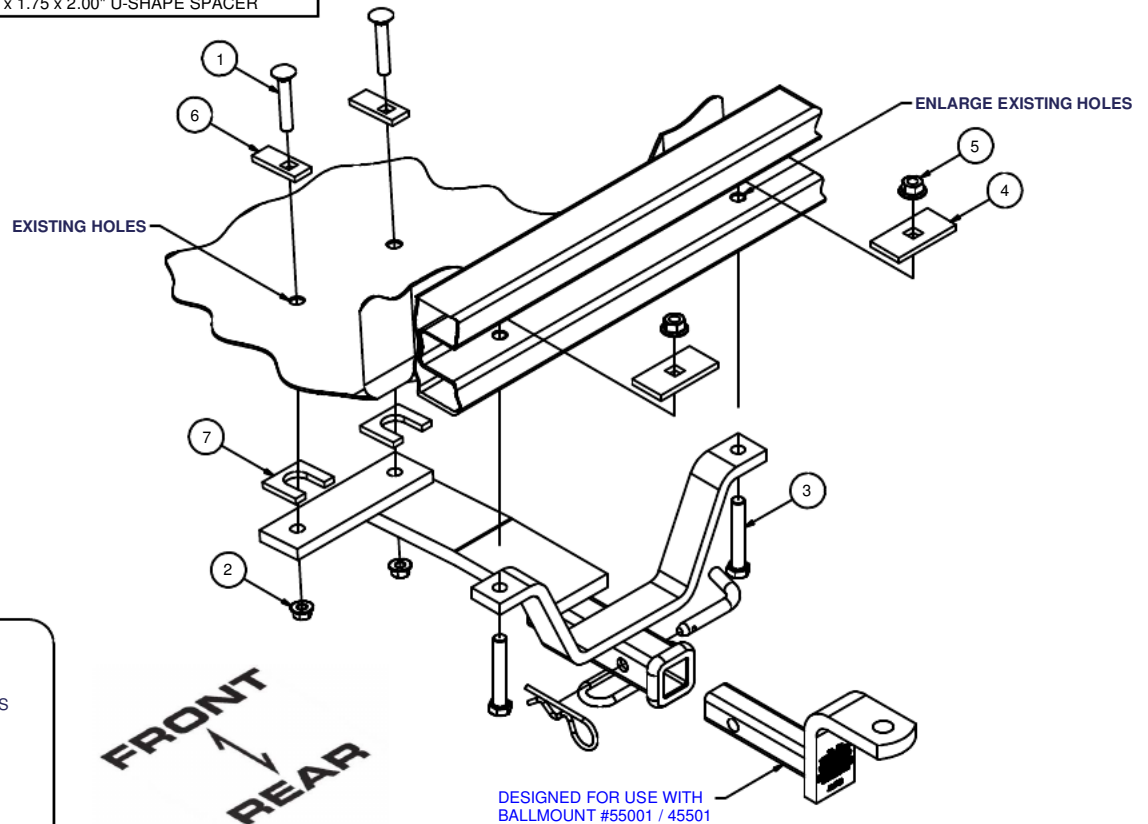
HITCH WEIGHT: 16 LBS.

INSTALL TIME

PROFESSIONAL: 30 MINUTESNOVICE (DIY): 60 MINUTES

INSTALL NOTES:

DRILLING REQUIRED

**INSTALLATION STEPS**

- 1) Remove two rubber drainage plugs from spare tire well. Remove contents from trunk area for installation of hardware.
- 2) Locate two small holes in bumper beam and drill out for 1/2" hardware.
- 3) Place 7/16" carriage bolts & spacers through the drainage holes from inside trunk.
- 4) Raise hitch into position. Place half moon shaped spacer between hitch and spare tire well as shown. Fasten with 7/16" flange nut.
- 5) Install 1/2" hex bolt up through hitch and drilled out hole in bumper beam. Fasten with 1/2" flange nut and spacer as shown.
- 6) Torque 7/16" fasteners to 70 lb.-ft and 1/2" fasteners to 110 lb.-ft.

**PERIODICALLY CHECK THIS RECEIVER HITCH TO ENSURE THAT ALL FASTENERS ARE TIGHT AND THAT ALL STRUCTURAL COMPONENTS ARE SOUND.**

Curt Manufacturing Inc., warrants this product to be free of defects in material and/or workmanship at the time of retail purchase by the original purchaser. If the product is found to be defective, Curt Manufacturing Inc., may repair or replace the product, at their option, when the product is returned, prepaid, with proof of purchase. Alteration to, misuse of, or improper installation of this product voids the warranty. Curt Manufacturing Inc.'s liability is limited to repair or replacement of products found to be defective, and specifically excludes liability for incidental or consequential loss or damage.