

11430

## CHEVROLET COBALT (EXCLUDING SS COUPE)

7/18/2012

GROSS LOAD CAPACITY WHEN USED AS A WEIGHT CARRYING HITCH: 2,000 LBS. TRAILER WEIGHT &amp; 200 LBS. TONGUE WEIGHT.

\*\*\*DO NOT EXCEED VEHICLE MANUFACTURER'S RECOMMENDED TOWING CAPACITY.\*\*\*

WARNING: ALL NON-TRAILER LOADS APPLIED TO THIS PRODUCT MUST BE SUPPORTED BY AUXILIARY STABILIZING STRAPS.

\*\* FAILURE TO PROPERLY SUPPORT NON-TRAILER LOADS WILL VOID PRODUCT WARRANTY\*\*

HAVING INSTALLATION QUESTIONS? CALL TECHNICAL SUPPORT AT 1-800-798-0813

| Parts List |     |                  |  |
|------------|-----|------------------|--|
| ITEM       | QTY | PART NUMBER      | DESCRIPTION                            |
| 1          | 4   | 1/2-13 x 1 1/4   | CARRIAGE BOLT                          |
| 2          | 2   | CM-SP20          | .250 x 1.50 x 4.00" SQUARE HOLE SPACER |
| 3          | 6   | HFN 1213         | HEX FLANGE NUT                         |
| 4          | 2   | 1/2 - 13 x 1 1/2 | HEX BOLT                               |
| 5          | 2   | FW12             | FW, 12, ZP                             |
| 6          | 2   | CM-SP4           | .250 x 1.50 x 3.00" SQUARE HOLE SPACER |

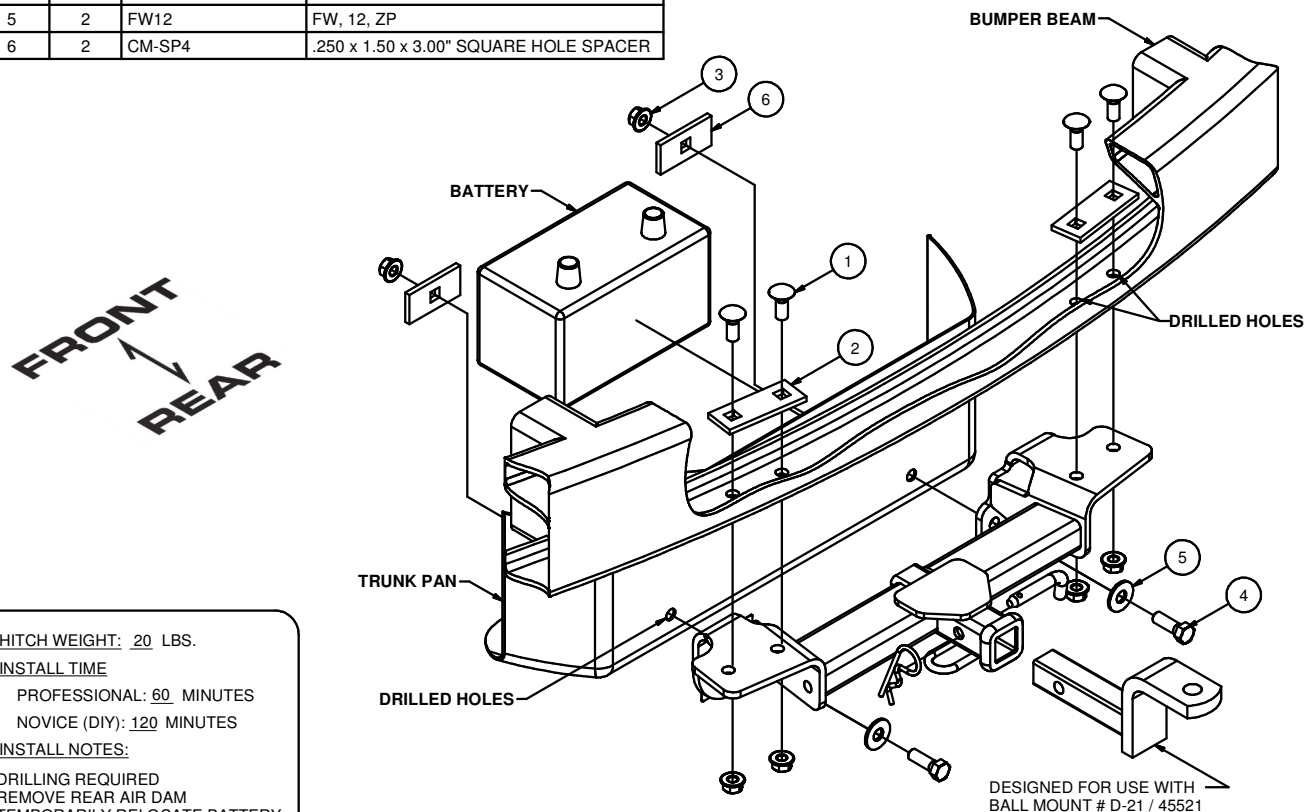

HITCH WEIGHT: 20 LBS.

## INSTALL TIME

PROFESSIONAL: 60 MINUTES

NOVICE (DIY): 120 MINUTES

## INSTALL NOTES:

- DRILLING REQUIRED
- REMOVE REAR AIR DAM
- TEMPORARILY RELOCATE BATTERY

## INSTALLATION STEPS

- 1) Remove trunk pan cover and move battery away from trunk pan wall for drill clearance. (Replace after install)
- 2) Remove rear air dam and return to vehicle owner.
- 3) Locate and mark the center of the vehicle on the bumper beam.
- 4) Position hitch on vehicle center. Mark and center punch (4) holes in bumper beam.  
(Note: with hitch centered make sure back of side plates sit flat against trunk pan.)
- 5) Drill center punched holes using a 1/2" drill bit.
- 6) Raise hitch into position and secure with carriage bolts, spacers, and flange nuts as shown.
- 7) Center punch remaining (2) holes in trunk pan and drill using a 1/2" drill bit.
- 8) Install hex bolts, washers, spacers, and flange nuts through trunk as shown. (Note: seal holes with silicone.)
- 9) Torque all 1/2" fasteners to 110 lb-ft.
- 10) Replace battery and trunk pan cover moved in step 1.

**PERIODICALLY CHECK THIS RECEIVER HITCH TO ENSURE THAT ALL FASTENERS ARE TIGHT AND THAT ALL STRUCTURAL COMPONENTS ARE SOUND.**

Curt Manufacturing Inc., warrants this product to be free of defects in material and/or workmanship at the time of retail purchase by the original purchaser. If the product is found to be defective, Curt Manufacturing Inc., may repair or replace the product, at their option, when the product is returned, prepaid, with proof of purchase. Alteration to, misuse of, or improper installation of this product voids the warranty. Curt Manufacturing Inc.'s liability is limited to repair or replacement of products found to be defective, and specifically excludes liability for incidental or consequential loss or damage.