

11428 / 24731 / 247428**KIA SPECTRA 5****8/7/2008**

GROSS LOAD CAPACITY WHEN USED AS A WEIGHT CARRYING HITCH: 2000 LBS. TRAILER WEIGHT & 200 LBS. TONGUE WEIGHT.
 DO NOT EXCEED VEHICLE MANUFACTURER'S RECOMMENDED TOWING CAPACITY.

Parts List			
ITEM	QTY	PART NUMBER	DESCRIPTION
1	3	M10 - 1.25 x 30	HEX BOLT
2	3	3/8"	CONICAL TOOTHED WASHER
3	1	1/2"	FISHWIRE TOOL
4	2	7/16-14	HEX FLANGE NUT
5	1	CM-SP35	.188 x 1.00 x 2.38" ROUND HOLE SPACER
6	2	7/16-14 x 1 1/2	HEX BOLT
7	1	HFN 1213	HEX FLANGE NUT
8	1	CM-SP1	.250 x 1.50 x 2.00" SQUARE HOLE SPACER
9	1	1/2-13 x 1 1/2	CARRIAGE BOLT

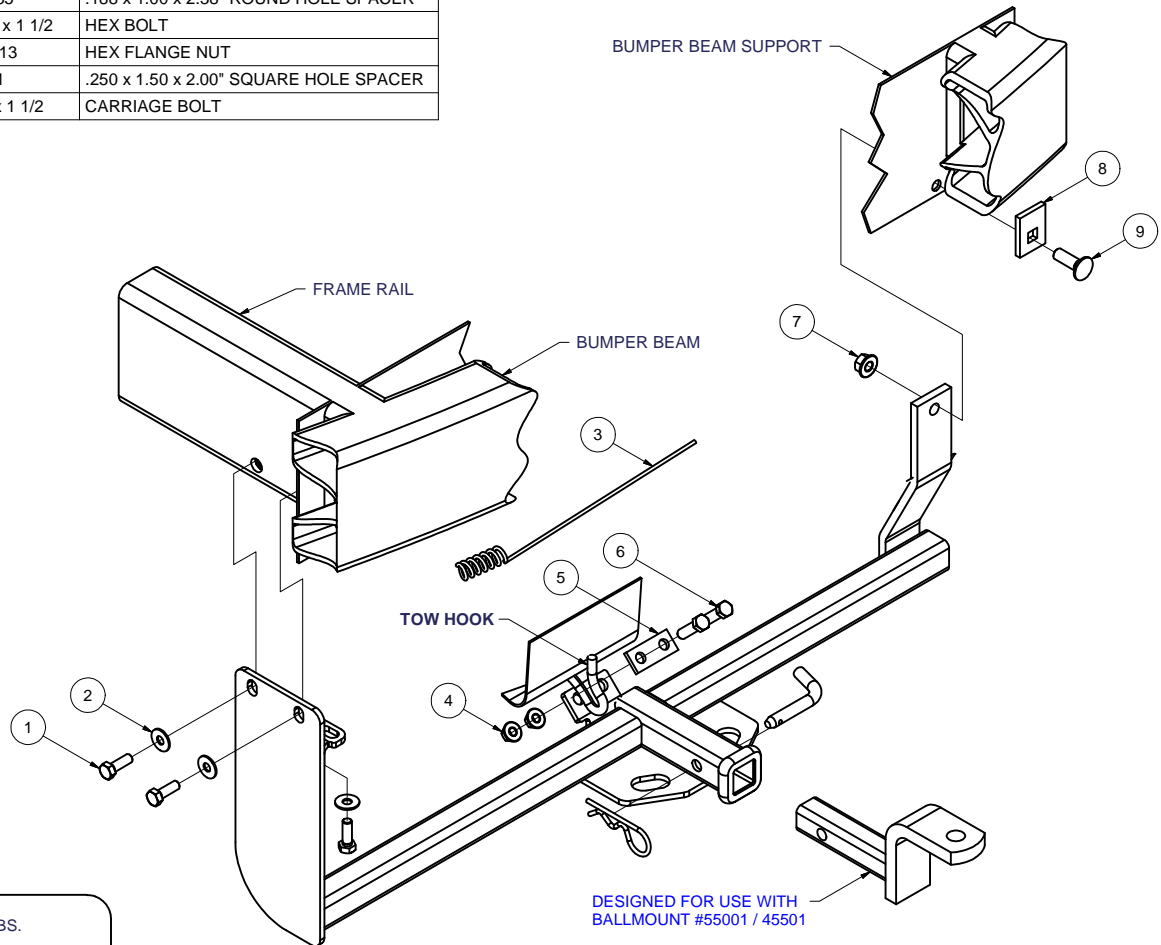

HITCH WEIGHT: 26 LBS.
 INSTALL TIME: 30 MINUTES
 INSTALL NOTES:
 -NO DRILLING REQUIRED
 -FISHWIRE HARDWARE

INSTALLATION STEPS

- 1) Remove M10 bolts from driver side frame rail.
- 2) Raise hitch into position and attach to tow hook using 7/16" hex bolts, spacer, and flange nuts as shown.
- 3) Secure driver side plate using M10 bolts and conical washers.
- 4) Secure passenger side plate using 1/2" carriage bolt, spacer, and flange nuts as shown.
(Note: Use fishwire if needed for ease of installation.)
- 5) Torque all M10 fasteners to 35 lb-ft, all 7/16" fasteners to 50 lb-ft, and all 1/2" fasteners to 75 lb-ft.

PERIODICALLY CHECK THIS RECEIVER HITCH TO ENSURE THAT ALL FASTENERS ARE TIGHT AND THAT ALL STRUCTURAL COMPONENTS ARE SOUND.

Curt Manufacturing Inc., warrants this product to be free of defects in material and/or workmanship at the time of retail purchase by the original purchaser. If the product is found to be defective, Curt Manufacturing Inc., may repair or replace the product, at their option, when the product is returned, prepaid, with proof of purchase. Alteration to, misuse of, or improper installation of this product voids the warranty. Curt Manufacturing Inc.'s liability is limited to repair or replacement of products found to be defective, and specifically excludes liability for incidental or consequential loss or damage.