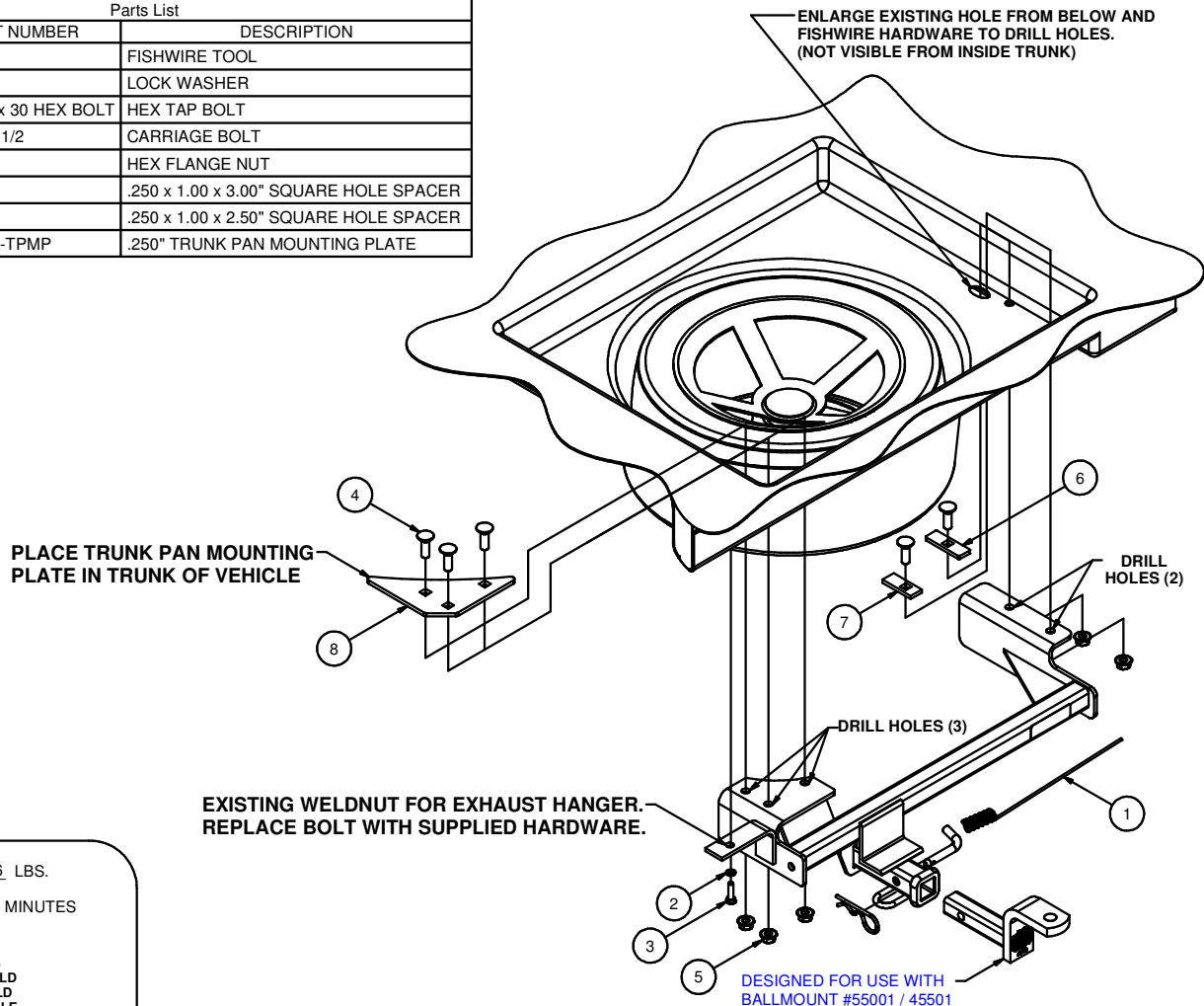

11353**MERCEDES CLK 350 (209 CHASSIS)**

12/5/2012

GROSS LOAD CAPACITY WHEN USED AS A WEIGHT CARRYING HITCH: 2000 LBS. TRAILER WEIGHT & 200 LBS. TONGUE WEIGHT.
*****DO NOT EXCEED VEHICLE MANUFACTURER'S RECOMMENDED TOWING CAPACITY.*****

Parts List				
ITEM	QTY	PART NUMBER	DESCRIPTION	
1	1	1/2"	FISHWIRE TOOL	
2	1	5/16"	LOCK WASHER	
3	1	M8 - 1.25 x 30 HEX BOLT	HEX TAP BOLT	
4	5	1/2-13 x 1 1/2	CARRIAGE BOLT	
5	5	HFN 1213	HEX FLANGE NUT	
6	1	CM-SP6	.250 x 1.00 x 3.00" SQUARE HOLE SPACER	
7	1	CM-SP10	.250 x 1.00 x 2.50" SQUARE HOLE SPACER	
8	1	CM-11353-TPMP	.250" TRUNK PAN MOUNTING PLATE	

HITCH WEIGHT: 26 LBS.INSTALL TIME: 60 MINUTES

INSTALL NOTES:

- DRILL (6) HOLES
- TRIM HEAT SHIELD
- TRIM SKID SHIELD
- ENLARGE (1) HOLE

INSTALLATION STEPS

- 1) Lower skid shield and rear most exhaust hanger, lift hitch into place.
- 2) Mark heat shield and skid shield to be trimmed as needed. Lower hitch and trim.
- 3) Lift hitch into place again and secure to exhaust hanger. Mark all holes for drilling.
- 4) Lower hitch and enlarge existing hole on passenger side to fit square hole spacer as shown, drill all holes (5).
- 5) Place trunk pan mounting plate in trunk with (3) 1/2" carriage bolts (driver side), and fishwire square hole spacers with 1/2" carriage bolts on the passenger side from under the vehicle.
- 6) Lift hitch into position and attach using 1/2" flange nuts. Replace exhaust hanger bolt with supplied M8 bolt and 5/16" lock washer.
- 7) Tighten all 1/2" hardware to 110 ft.-lb. and M8 to 23 ft.-lb.
- 8) Re-attach skid shield and exhaust hanger.

PERIODICALLY CHECK THIS RECEIVER HITCH TO ENSURE THAT ALL FASTENERS ARE TIGHT AND THAT ALL STRUCTURAL COMPONENTS ARE SOUND.

Curt Manufacturing Inc., warrants this product to be free of defects in material and/or workmanship at the time of retail purchase by the original purchaser. If the product is found to be defective, Curt Manufacturing Inc., may repair or replace the product, at their option, when the product is returned, prepaid, with proof of purchase. Alteration to, misuse of, or improper installation of this product voids the warranty. Curt Manufacturing Inc.'s liability is limited to repair or replacement of products found to be defective, and specifically excludes liability for incidental or consequential loss or damage.